



**ICTS**

INTERNATIONAL  
CENTRE *for*  
THEORETICAL  
SCIENCES

TATA INSTITUTE OF FUNDAMENTAL RESEARCH

## **TENDER DOCUMENT**

### **TECHNICAL BID**

#### **SALIENT GOVERNING FEATURES OF THE TENDER/ WORKS 2008**

(Operative Schedule of Individual Tender)

**NAME OF WORK:** Providing, Supply and Fixing of Furniture, Toilet cubicle, lockers and allied works for various facilities of ICTS-TIFR campus, Shivakote village, Hessarghatta Hobli, Bengaluru North.

**NIT NO:** ICTS/TIFR/Civil/02/10/2025-26 dated: 31<sup>st</sup> Oct 2025

**TENDER DOCUMENTS ISSUED TO:**

**M/s.**

**Engineer - Civil**

*ICTS-TIFR Campus, Survey No. 151, Shivakote  
Bengaluru - 560 089.*

*Telephone Number: Tel: +91 - 80 - 4653 6000*

*Fax: +91 - 80 - 4653 6002*

# INDEX

REF	PARTICULARS	PAGE
1	ITEM RATE TENDER & CONTRACT FOR WORKS	3
2	SCHEDULES	
A	<b>Reference to NIT &amp; Tender Documents</b>	5
B	Schedule of materials to be issued to the contractor	5
C	Land earmarked for temporary infrastructure, Tools & plants to be hired to the contractor	5
D	Extra schedule for specific requirements / documents for the work if any	5
E	Reference to the Book of “Conditions & Clauses of Contract” to be followed for this work.	6
F	General rules & directions	6
	Definitions with reference the project / work.	6
	<b>Clause-1:</b> Time allowed for submission of Performance Guarantee from the date of issue of letter of acceptance / WO & Maximum allowable extension beyond the same	6
	<b>Clause-2:</b> Authority for fixing compensation under clause 2	6
	<b>Clause-5:</b> No. of days from the date of issue of WO for reckoning date of start.	6
	<b>Table of Milestone(s)</b>	7
	<b>Clause-10-A:</b> List of testing equipment to be provided by the contractor at site lab	7
	<b>Clause-10 B (ii):</b> Applicability of payment of Mobilization Advance	7
	<b>Clause-10 C:</b> Component of labour in percent of value of work	7
	<b>Clause-10 CA:</b> Materials covered under this clause for escalation	7
	<b>Clause-10CC:</b> Period for applicability of the clause	7
	<b>Clause-12:</b> Deviation limits for applicability of this clause 12.2, 12.3 & 12.5	7
	List of Changes	8
	Special Terms and Conditions	10
	Notice for Invitation of Tender	13
	Scope of Works	17-18
	Letter of Transmittal	19
	Form A - Financial Information	21
	Form B - Details of similar works completed during the last five years	22
	Form C - Details of the Projects under Execution	23
	Form D - Performance Report of works referred to in Form ‘B’ & ‘C’	24
	Form E - Structure and Organisation	25
	Form F - Technical Qualification Assessment Summary	27
	Form G - Bid Security Declaration	28
	Financial Bid – Schedule of Quantities	29-36
	Annexure 1 - Pre-qualification of Contractors - Profile - Details of Organisation	37
	Annexure 2 - Litigation History	38
	Annexure 3 - Format for Bill payment through Electronic Mode	39
	Annexure 4 - Site Inspection Report	40

**Signature of Tenderer with Seal**

INTERNATIONAL CENTRE FOR THEORETICAL SCIENCES

TATA INSTITUTE OF FUNDAMENTAL RESEARCH

ITEM RATE TENDER & CONTRACT FOR WORKS

i)	Name of work	Providing, Supply and Fixing of Furniture, Toilet cubicle, lockers and allied works for various facilities of ICTS-TIFR campus, Shivakote village, Hessarghatta Hobli, Bengaluru North.
ii)	Pre bid meeting	As per CPPP document
iii)	Date & Time of submission	As per CPPP document
iv)	Date & Time of opening of technical bid	As per CPPP document

TENDER DOCUMENTS ISSUED TO M/S. ....  
.....

Date of issue: .....

Engineer - Civil

**Signature of Tenderer with Seal**

**TENDER**

I / we have read and examined the Notice Inviting Tender, Salient Governing Features of the Tender / Work including Schedules A, B, C, D, E & F, **Specifications Books \***, Drawings and Designs, General Rules & Directions, General Clauses of Contract, Special Clauses of Contract & other documents and rules referred to in the **Conditions and Clauses of Contract** and all other contents in the tender documents for the work.

(\* **Note:** *The “Specifications / Conditions and Clauses of Contract books” are enclosed*)

These books, as required / specified in this “Salient Governing Feature of the Tender / Work” herein below, shall remain part of the tender documents / Contract / agreement to be executed, and signed by both the parties after acceptance of the Tender.

I / we, hereby tender for the execution of the work specified for the President of India within the time specified in Schedule “F”, viz., Schedule of Quantities and in accordance in all respects with the specifications, designs, drawings and instructions in writing referred to in Rule 1 of General Rules and Directions and in Clause - 10 of the General Clauses of Contract and with such materials as are provided for, by, and in respects in accordance with, such conditions so far as applicable.

We agree to keep the tender open for **one hundred eighty (180) days** from the last date of its submission and not to make any modifications in its terms and conditions.

I / we hereby declare that in lieu of EMD, we will submit a Bid Securing Declaration in the format provided in Form “G”.

I / we hereby declare that I / we shall treat the tender documents, drawings and other records connected with the work as secret / confidential documents and shall not communicate information derived there-from to any person other than a person to whom I / We am / are authorised to communicate the same or use the information in any manner prejudicial to the safety of the State.

**Signature of Contractor**  
Postal Address

**Dated**

**Witness**

**Address**

**Occupation**

---

**A C C E P T A N C E**

The above tender (as modified by you as provided in the letters mentioned hereunder) is accepted by me for and on behalf of the CENTRE DIRECTOR, ICTS for a sum of Rs...../- (Rupees..... ).

The letters referred to below shall form part of this contract Agreement.

- i)
- ii)
  
- iii)

Signature  
Designation

**Signature of Tenderer with Seal**

Dated .....

## Salient Governing Features of the Tender / Work Proforma of Schedules

<b>SCHEDULE 'A'</b> Reference to NIT & Tender Documents			
SN	TITLE	PARTICULARS	PAGE
1	Changes in conditions of contract	Correction Slip: CDN / C1, C2 & C3	<b>10-23</b>
2	Notice Inviting Tender (NIT) No.	<b>NIT NO:</b> ICTS/TIFR/Civil/02/10/2025-26 dated: 31 <sup>st</sup> Oct 2025	
3	Notice Inviting Tender details	i) NIT as uploaded on ICTS Website	Yes
		ii) NIT as published in CPP portal.	Yes
		iii) NIT as circulated to pre-qualified Agencies.	No
4	Scope and location of the work:	Enclosed	<b>17</b>
5	List of drawings/Image	Enclosed	<b>Yes</b>
6	Time Schedule for the work:	Enclosed	<b>NA</b>
7	List of changes if any in specifications:		
	a) Specifications of Civil works – 2023	DAE -DCSEM	Yes
	b) Conditions & Clauses of contract 2008	DAE-DCSEM	Yes
8	Schedule of Quantities (Enclosed) -	<b>Please refer Financial Bid</b>	
9	Tender Submission	<b>Online submission through CPP portal within in due date.</b>	

<b>SCHEDULE 'B'</b>				
Schedule of materials to be issued to the contractor.				
S. No	Description of item	Quantity	Rates at which the Materials will be charged to the contractor.	Place of issue
1	2	3	4	5
1.	Plywood, Rubber wood, HDMR sheet SS/MS fabrication materials, Soft / Writing board, Compact laminate panels, glass etc.,		Contractor's own supply.	NA
2.	Hardware's, locking arrangement, wooden plugs, SS star headed screws, nails, etc.,		Contractor's own supply.	NA
3.	Electricity for fabrication.		Departmental supply – Free supply. Extension cable - Contractor's shall make their own arrangement.	NA
4	All specified materials		Contractor's own supply	NA

<b>SCHEDULE 'C'</b>
Land earmarked for temp. infrastructures and Tools & plants to be hired to the contractor

**Signature of Tenderer with Seal**

S.No	Description	Hire charges	Place of issue
1	2	3	4
1.	Area for storage (SCC-10)	As per Clause SCC-10	Utility block sump area.
2.	Temporary Buildings (SCC-12)	As per Clause SCC-12	Contractors must make their own arrangement. No space available inside the campus.
3.	Labour hutments (SCC-12)	No labor hutment permitted at site/campus.	
<b>SCHEDULE 'D'</b>			
Extra schedule for specific requirements / documents for the work, if any Particularly for Security guidelines, Gate pass, lift, tower crane etc.,			Yes.

<b>SCHEDULE 'E'</b>	Reference to the Book of "Conditions & Clauses of Contract" to be followed for this work	As enclosed
<b>Name of Work:</b> Providing & Supply and Fixing Furniture, Toilet cubicle, lockers and allied works for various facilities of ICTS-TIFR campus, Shivakote village, Hessarghatta Hobli, Bengaluru North.		As per NIT
Estimated cost of work:	Rs. 18,90,000.00	As per NIT
i) Earnest money	Rs.37,800.00 (2% of tendered value)	As per NIT
ii) Performance Guarantee	5% of tendered value	As per Tender
iii) Security Deposit	5 % of tendered value	As per Tender

<b>SCHEDULE 'F'</b>		
<b>General Rules &amp; Directions :</b>		
Tender inviting authority	Center Director, ICTS	
Quantity of Items of work to be executed with any price variation.	As per actuals.	
<b>DEFINITIONS:</b> (CCC-2008, P. 10)		
(v)	Engineer-in-charge	Engineer- Civil, ICTS
2(viii)	Accepting Authority	Center Director, ICTS
2(x)	Percentage on cost of materials and labour to cover all overheads & profits	15% (Fifteen percent)
2(xii)	Department	ICTS-TIFR, Grant-in Aid institute under Department of Atomic Energy
9(ii)	Standard Contract Form of Dept.	Item Rate Tender
<b>CLAUSE – 1</b> (CCC-2008, P.13)		
i)	Time allowed for submission of Performance Guarantee from the date of issue of letter of acceptance / WO.	15 days
ii)	Maximum allowable extension beyond the period (provided in (i) above.)	7 days with an interest of 0.5% per week of delay computed on a per day basis.
<b>CLAUSE – 2</b> (CCC-2008, P.14)		
Authority for fixing compensation under relevant clauses.	Center Director, ICTS	
<b>CLAUSE – 5</b> (CCC-2008, P.15)		

**Signature of Tenderer with Seal**

Number of days from the date of issue of letter of acceptance / WO for reckoning date of start.		15 days	
Milestone(s) as per table given below:			
<b>TABLE OF MILESTONE(S)</b>			
Sl. No.	Description of Milestone (Physical)	Time Allowed in days. (From date of start)	Amount to be with-held in case of non-achievement of milestone
1.	Material procurement, erection and commission.	60 days	-
Time allowed for execution of work		60 days.	
Authority to decide: i) Extension of time ii) Re-scheduling of Milestone		Center Director, ICTS. NA	

<b>Clause - 10A</b> (CCC-2008, P. 19)	List of testing equipment to be provided by the contractor at site.		
Drilling machine	Wood Cutting machine.	Grinding machine. Welding machine. etc,	Staging & scaffolding material, Wood sander.
Additional tools and plants required for completion of work.	Required for execution of varies trades of work shall be arranged as per the work requirement.		

<b>Clause – 10B (ii): (CCC – 2008, P. 20)</b>	<b>(Mobilization Advance)</b>
Whether Clause 10 B (ii) shall be applicable <b>(If yes, Clause of Tender Condition to be followed)</b>	<b>Not Applicable.</b>

<b>Clause – 10C:</b>	Component of labour expressed as percent of value of the work <b>(CCC – 2008, P. 21)</b>	<b>25%</b>
----------------------	--	------------

<b>Clause – 10CA:(CCC – 2008, P. 21) Not Applicable</b>			
S. No	Materials Covered under this Clause	Nearest Materials for which All India Wholesale Price Index is to be followed	<b>Basic Rate</b>
1	<b>Cement</b>	<b>Grey Cement</b>	-
2	<b>Steel reinforcement bars</b>	<b>Steel (Re-bars)</b>	-

**\*Note:** Base price for materials given above are only for regulating operation of clause 10-CA. The tenderers are requested to consider prevailing market rates while quoting the rates.

<b>Clause – 10CC:(CCC – 2008, P. 22):</b>	<b>Not Applicable</b>
---	-----------------------

<b>Clause – 12: (CCC – 2008, P. 25) Not Applicable</b>		
12.2 & 12.3	Deviation Limit beyond which clauses 12.2 & 12.3 shall apply for building works	30%
12.5	Deviation Limit beyond which clauses 12.2 & 12.3 shall apply for foundation work	100%
12.5	Deviation Limit beyond which clauses 12.2 & 12.3 shall apply for maintenance work	---

Clause – 36(i) **Requirement of Technical Representative(s) and recovery Rate**

**Signature of Tenderer with Seal**

Sl. No.	Minimum Qualification of Technical Representative	Discipline	Designation (Principal Technical / Technical representative)	Min. Exp. In yrs.	No.	Rate per month at which recovery shall be made from the contractor in the event of not fulfilling provision of clause 36(i).
.	Site Engineer	Diploma in Civil Engineering	Site in charge	5	1	Rs.35,000.00

**Note:** i) Assistant Engineers / Scientific Officer- "C" & above, retired from Govt. services that are holding Diploma, will be treated at par with Graduate Engineers.

ii) The contractor to deploy adequate Nos. of technicians, site supervisors, accounts & office staff, till completion of works.

Engineer- ICTS,

**Notes:**

1. In the case of any discrepancy between these "Salient Governing Features of the Tender/Work" & the book "Conditions and Clauses of Contract, stipulations given in these "Salient Governing Features of the Tender/Work" shall take precedence.

2. It will be the responsibility of the Contractor to get the character & antecedents of the regular staff & Supervisors, engaged by them, for carrying out the work being awarded to him, verified from the Police authorities and produce the report of the verification to the Security at the gate under intimation to Engineer-in-Charge of the work.

**CDN/C-1: LIST OF CHANGES / MODIFICATION IN THE CCC - 2008**

SN	Existing Provision	Modified Provision
1	<b>SECTION - 1: NOTICE INVITING TENDERS</b>	
1.1	<b>Schedule -E Page 6 :</b> <b>Earnest Money Deposit (E.M.D.): Rs.37,800.00</b>	
2	<b>SECTION - 2: ITEM RATE TENDER &amp; CONTRACT FOR WORKS</b>	
2.1	New para is added as second last para, Page 8: I / We undertake and confirm that eligible similar work(s) has/ have not been executed through another contractor on a back-to-back basis. Further that, if such a violation comes to the notice of the Department, then I/we shall be debarred for tendering in ICTS in future forever. Also, if such a violation comes to the notice of the Department before the date of start of work, the Engineer-in-Charge shall be free to forfeit the entire amount of Earnest Money Deposit/Performance Guarantee.	
3	<b>CONDITION OF CONTRACT</b>	
3.1	<b>Date of commencement of work</b> – The date of commencement of work shall be the date of start as specified in Schedule For the 1 <sup>st</sup> date of handing over of the site, whichever is later, in accordance with the phasing if any, as indicated in the tender document.	
4	<b>GENERAL CLAUSES OF CONTRACT (GCC)</b>	
4.1	In the event of the contract being determined <b>or rescinded</b> under the provisions of any of the clause/ condition of the agreement, the performance guarantee shall stand forfeited in full and shall be absolutely at the disposal of the DIRECTOR-ICTS.	
4.2	Clause 1A para 1, Page No.6  The person(s) whose tender may be accepted (hereinafter called the contractor) shall permit Government at the time of making any payment to him for work done under the contract to deduct a sum at the rate of <b>5%</b> of the gross amount of each running bill till the sum will amount to security deposit of 5% of the tendered value of the work.	
4.3	<b>DEVIATION, EXTRA ITEMS AND PRICING:</b>	

**Signature of Tenderer with Seal**

	In the case of extra item (s) (items that are completely new, and are in addition to the items contained in the contract), the contractor may within fifteen days of receipt of order or occurrence of the item (s) claim rates, supported by proper analysis, for the work and the engineer-in-charge shall within one month of the receipt of the claims supported by analysis, after giving consideration to the analysis of the rates submitted by the contractor, determine the rates on the basis of the market rates and the contractor shall be paid in accordance with the rates so determined.
4.9.2	In the case of substituted items (items that are taken up <b>with partial substitution or in lieu of items of work in the contract</b> ) the rate for the agreement item (to be substituted) and substituted item shall also be determined in the manner as mentioned in the following para.
4.10	<p>Carrying out part work at risk &amp; cost of contractor:</p> <p><b>If contractor:</b></p> <p>i) At any time makes default during currency of work or does not execute any part of the work with due diligence and continues to do so even after a notice in writing of 7 days in this respect from the Engineer-in-Charge; <b>or</b> ii) Commits default in complying with any of the terms and conditions of the contract and does not remedy it or takes effective steps to remedy it within 7 days even after a notice in writing is given in that behalf by the Engineer-in-Charge; <b>or</b></p> <p>iii) Fails to complete the work(s) or items of work with individual dates of completion, on or before the date(s) so determined and does not complete them within the period specified in the notice given in writing on that behalf by the Engineer-in-Charge. The Engineer-in-Charge without invoking action under clause 3 may, without prejudice to any other right or remedy against the contractor which have either accrued or accrue thereafter to Government, by a notice in writing to take the part work/part incomplete work of any item(s) out of his hands and shall have powers to:(a) Take possession of the site and any materials, constructional plant, implements, stores, etc., thereon; <b>and/or</b>(b) Carry out the part work / part incomplete work of any item(s) by any means <b>at the risk and cost of the contractor</b>. The Engineer-in-Charge shall determine the amount, if any, is recoverable from the contractor for completion of the part work/ part incomplete work of any item(s) taken out of his hands and execute at the risk and cost of the contractor, the liability of contractor on account of loss or damage suffered by Government because of action under this clause shall not exceed 10% of the tendered value of the work. In determining the amount, credit shall be given to the contractor with the value of work done in all respect in the same manner and at the same rate as if it had been carried out by the original contractor under the terms of his contract, the value of contractor's materials taken over and incorporated in the work and use of plant and machinery belonging to the contractor. The certificate of the Engineer-in-Charge as to the value of work done shall be final and conclusive against the contractor provided that action under this clause shall only be taken after giving notice in writing to the contractor. Provided also that if the expenses incurred by the department are less than the amount payable to the contractor at his agreement rates, the difference shall not be payable to the contractor. Any excess expenditure incurred or to be incurred by Government in completing the part work/ part incomplete work of any item(s) or the excess loss of damages suffered or may be suffered by Government as aforesaid after allowing such credit shall without prejudice to any other right or remedy available to Government in law or per as agreement be recovered from any money due to the contractor or any account, and if such money is insufficient, the contractor shall be called upon in writing and shall be liable to pay the same within 30 days. If the contractor fails to pay the required sum within the aforesaid period of 30 days, the Engineer-in-Charge shall have the right to sell any or all of the contractors' unused materials, constructional plant, implements, temporary building at site etc. and adjust the proceeds of sale thereof towards the dues recoverable from the contractor under the contract and if thereafter there remains any balance outstanding, it shall be recovered in accordance with the provisions of the contract. In the event of above course being adopted by the Engineer-in-Charge the contractor shall have no claim to compensation for any loss sustained by him by reason of his having purchased or procured any materials or entered into any engagements or made any advance on any account or with a view to the execution of the work or the performance of the contract."</p>
4.10	The contractor shall also abide by the provision of the Child labour (Prohibition & Regulation) Act - 1986.

**Signature of Tenderer with Seal**

4.12	No labour below 14 years: No labour below the age of 14 (fourteen) years shall be employed on the work.
4.13	<b>LEVY/ TAXES PAYABLE BY CONTRACTOR:</b> i) <b>GST, Building and other Construction Workers Welfare Cess or any other applicable tax or cess</b> in respect of this contract shall be payable by the contractor and the Government shall not entertain any claim whatsoever in this respect.

### **SPECIAL TERMS AND CONDITIONS**

1. Makes of various materials to be used by contractors will be according to the list of approved makes given. No other makes will be used by the contractor.
2. Contractor will first get the sample approved by ICTS Engineer before procuring the material in bulk and incorporating it in the work.
3. Contractor will be paid based on units specified in the tender. No extra measurement factor will be applied for the measurement Contractor so desires, he/she can visit the site and see the actual site before quoting.
4. Contractor will arrange all safety measures and Covid -19/pandemic guidelines at his own cost and will take all safety measures. If it is observed that work is proceeding without adequate safety precautions, work may be stopped by the Engineer. And in such cases, contractors will be solely responsible for the delay and its consequences thereof.
5. Electrical power: -Construction electrical power will be supply to the contractor at free of cost at one convenient point. Contractors shall take all necessary safety precautions in carrying electrical power as the campus has a residential colony and kids play around.

**Signature of Tenderer with Seal**

## **NOTICE FOR INVITATION OF TENDER**

**NIT NO.:** ICTS/TIFR/Civil/02/10/2025-26 dated: 31<sup>st</sup> Oct 2025

Administrative Officer, ICTS-TIFR Campus, Survey No. 151, Shivakote Bengaluru - 560 089, on behalf of the CENTRE DIRECTOR, ICTS, invites sealed tenders (in two bid), from eligible contractors for the work and details as given below:

**NAME OF WORK:** - Providing, Supply and Fixing of Furniture, Toilet cubicle, lockers and allied works for various facilities of ICTS-TIFR campus, Shivakote village, Hessarghatta Hobli, Bengaluru North.

**Estimated Cost** Rs.18,90,000.00

**E.M.D.:** 37,800.00

**Performance guarantee @ 5% + Security Deposit @ 5% of value of tender.**

**Defect liability period:** 01 Year.

**Completion Period-** 60 days.

**ELIGIBILITY/ QUALIFICATION:** As per NIT stipulation the bidders shall furnish all the requested documents.

**GST registration certificate; PAN** (Permanent Account Number) for reference.

The estimated cost for the work is projected to be Rs. 18,90,000.00 (approx.). Time of completion is 60 days. The interested agencies are required to furnish the following documents along with the Tender Document. (Joint ventures are not accepted).

- a) Proof of registration with Government / Semi Government organizations like Railways, PWD, CPWD, MES, Private works etc., in appropriate class or having experience in carrying out Electrical internal/external works.
- b) Annual turnover as per ITCC or Profit & Loss statement for the last 3 years.
- c) 'PAN' reference,
- d) Latest Bank Solvency Certificate of Minimum Value Rs. 7.56 Lakhs.
- e) GST registration certificate,
- f) Performance Certificates.

**Signature of Tenderer with Seal**

- g) List of works in hand/ ongoing works indicating the Agency for whom the work is undertaken, Value of work, Completion time, stipulated date of completion & present status of the work.
- h) Completed works carried out by them for the last seven years indicating the Agency for whom executed, Value of work, Completion time, Stipulated & Actual date of completion of the work.
- i) List of Technical staff they possess.
- j) List of construction plants, machinery & infrastructure facilities they possess.

**Agencies fulfilling following criteria shall be eligible to participate:**

(a) Experience of having successfully completed similar works during last seven years ending 31-03-2025.

(i) 3 works completed costing not less than Rs.7,56,000.00 each.

**or**

(ii) 2 works completed costing not less than Rs.11,34,000.00 each.

**or**

(iii) 1 work completed costing not less than Rs. 15,12,000.00

(iv) **Similar works shall mean, the agencies having the experience in carrying out internal furniture works/carpentry work/ modular furniture works/ civil contractors having executed supply and installation of furniture of value mentioned above.**

**(v) The agency shall have their registered office/ establishment in Bengaluru.**

**(vi) The authorized technical representative of bidders shall visit the site compulsory to understand the scope of work before submission of tender documents. (Site visit endorsement obtain from ICTS shall be submitted along with the tender documents).**

(vii) Bank Solvency Certificate of Minimum Value Rs. 7.56 Lakhs.

(viii) Average Annual turnover during the last 3 years ending 31.03.2025 should be at least Rs. 18.90 Lakhs.

The value of annual turnover figures shall be brought to its current value by enhancing the actual turnover figures to the simple rate 7% per annum.

[ix] Not having incurred any loss in more than 2 years during the last 5 consecutive immediate financial years ending 31-03-2025.

**3. TENDER DOCUMENTS CAN BE DOWNLOADED** between dates mentioned in the CPP document from [CPP portal](#).

**4. PROSPECTIVE AGENCIES TO SATISFY THEMSELVES** by fulfilling all the NIT criteria before submission of the tender.

**5. PRE-BID MEETING** shall be held on the date mentioned in the CPP document at ICTS, TIFR at Survey No.151, Shivakote Hessarghatta, Hobli, North Bangalore.

**Signature of Tenderer with Seal**

**6. SUBMISSION OF TENDER:** The Tender for the work shall be received up to the date mentioned on the CPP document. The documents shall consist of following:

**A) TECHNICAL BID**

- 1) *Eligibility Credentials as stipulated under para 2 above.*
- 2) *Technical Bid of the Tender Document*
- 3) *Tender Drawings. -NA*

**B) FINANCIAL BID**

**Note:** *a) The tender is to be submitted online (e-tendering process). The Technical Bids shall be opened first, and the bids shall be evaluated. The date of opening of financial bid shall be informed separately.*

*b) In case the last date of submission of tender is declared as holiday, the respective dates shall be treated as postponed to the next working day accordingly.*

**7. THE DEPARTMENT RESERVES THE RIGHT** to verify the particulars furnished by the applicant independently and accept/ reject the tender without assigning any reason thereof. Short listing of the agencies shall be subject to thorough verification of their credentials and inspection of works carried out by them, through a Technical Evaluation Committee of experts, constituted by ICTS.

**8. IF ANY INFORMATION FURNISHED** by the applicant is found to be incorrect at a later stage, they shall be liable to be debarred from tendering / taking up works in ICTS. ***(Please contact on (080) 4653 6027; Fax: (080) 4653 6002 for more details).***

**Signature of Tenderer with Seal**



### **NIT FOR CONTRACTING AGENCIES**

**Name of Work:** Providing, Supply and Fixing of Furniture, Toilet cubicle, lockers and allied works for various facilities of ICTS-TIFR campus, Shivakote village, Hessarghatta Hobli, Bengaluru North.

**NIT NO.:** ICTS/TIFR/Civil/02/10/2025-26 dated: 31<sup>st</sup> Oct 2025

International Centre for Theoretical Sciences (ICTS) -TIFR invites Pre-qualification applications from reputed, qualified, experienced, and financially sound Engineering construction agencies for “Providing and laying Vitriified tile flooring for Madhava Lecture hall and allied works in ICTS campus near Shivakote Village, Bangalore.”. Estimated Cost **Rs. 18,90,000.00**, Completion Period **60(Sixty) days**.

Tender documents to be downloaded from **the dates mentioned in the CPP document**

Last date & time for submission of Tender documents **as per the CPP document**

Opening of Technical bid will be held on the same day.

For further information/clarifications please contact Shri Mohan G. Ph: 9164752581, e-mail [mohan.gowda@icts.res.in](mailto:mohan.gowda@icts.res.in) or Rajalakshmi S Ph: 080 4653 6027 / 99161 90935, **e-mail:** [purchase@icts.res.in](mailto:purchase@icts.res.in)

#### **SCOPE AND LOCATION OF WORK:**

**1. LOCATION:** ICTS project site at Survey No. 151, Shivakote village, Hesaraghatta Hobli, North Bangalore.

**Signature of Tenderer with Seal**

## **SCOPE OF WORKS:**

1. Providing and fixing modular furniture viz, storage unit, wall unit/ under/above counter storage boxes/liner storage box, cupboard etc., for the following with open and close type, with & without shutter, at all heights in all floors etc., using 16 mm approved quality marine calibrated plywood as per latest revision of IS- 710 of M/s. Kit ply /M/s Merino/M/s. Century/M/s. Greenlam for all-round boxing, shutter, shelves and frame with approved colour and make 0.80mm thick laminate of approved shade for the entire storage/boxing unit and shutter (External /internal surfaces) properly framed and jointed, including labour charges approved brand hardware's, locking arrangement, etc complete, including cost of labour for fixing building hardware like concealed handle 150mm/100mm profile handles, Magnetic catch, soft closing box/cabinet hinges, Speciality locks of M/s. Ebco matching with Secu Rite cupboard lock with brass keys (P-SRC-20B) etc., complete as per specifications including providing and fixing edge binding with 2 mm thick of M/s. Rehau or M/s. LG PVC lipping of suitable width on all cut edges, wooden plugs, SS star headed screws, nails, etc., complete with all lead and lift all as directed by EIC.

2. Providing, supplying and fixing storage units/ open display shelves unit, storage boxes, cupboard etc., for the following at all heights & floors etc., using 25mm/18mm/12mm finger jointed first quality natural rubber board of approved brand & quality without any knots and black patches for all-round boxing, shutter, shelves and frame properly framed and jointed using wooden dowel/ plug of required sizes and dovetail joint with approved quality adhesive, Fevicol, approved brand hardware's/ fitting & fixtures ,locking arrangement, under count telescopic drawer channel, soft closing hinges, wooden knob and leg made to required profile and size from the same board, cut to size etc complete, including cost of labour for fixing building hardware like concealed handle 150mm/100mm profile handles for each shutter, Magnetic catch, Speciality locks of M/s. Ebco matching with Secu Rite cupboard lock with brass keys (P-SRC-20B) etc., complete as per specifications including polishing all internal & external surfaces including preparing the surface, applying a coat of sealer, 3 coats of neutral polish and final satin melamine spray finish SS star headed screws, nails, etc., complete with all lead and lift etc., all as per drawing and as directed by EIC. Note: (1) The thickness of board for vertical partition/support and horizontal shelves shall be minimum 18mm thick finger jointed rubber board unless otherwise specified. (2) The door shutter for storage units etc., shall have 75mm wide vertical, horizontal, middle and lock rail unless otherwise specified.

3. Providing, supplying finger jointed approved quality rubber wood panel board of size 2400mm x1200mm of following thickness including transportation at all leads all as directed by EIC.

4. Table & seating bench: Providing, designing and making built up section using 25mm thick finger jointed rubber wood board for Table top & bench top as per the approximate sizes 1050mm x 1050mmx750 - 2 Nos, 750mm x 750mm- 2 Nos and seater is 1050mm x 450mm - 4 Nos and 750mm x 450mm - 4 Nos. in square /rectangular or any geometric shape symmetrical/ asymmetrical design or any approved shape at all leads & heights etc., fixed on SS tubular frame ( which will be paid under separate item) SS screws, including providing 100mmx25mm wide additional member all-round to given appearance of 50mm thick and tapered slope to inside as shown in drawing including PU polish finish after surface preparation on all exposed areas, sealers, cost of labour, wastages, adhesive, Nails/S.S screws etc., complete as per the detailing & as specified etc., all directed by EIC.

5. SS frame work : Providing, supplying fabricating SS frame work for table and bench support and kitchen storage rack, SS frame for refrigerator support, using hollow tubes/ flats/ angle using SS 304 grade profile of M/s Zindal / M/s JSW to required size including finishing all the welded joints, providing 5mm thick plate lugs with hole at all corners and intermediate support members for fixing top wooden planks, M6/M8 size Levelling Screw Set of 4 Nos/ heavy duty adjustable furniture leg Leveller with SS nuts one welded to frame bottom, SS washer, cover plate for legs etc., complete as per the detailing & as specified etc., all directed by EIC

6.Soft pinup board: Providing, supplying and fixing pinup board of approximate size 2.40mts x 1.2mt using 12mm thick soft fibre board glued over 4mm thick water proof HDHMR sheet fixed in level with finger jointed rubber wood frame making a rebate of 4mm at back and painting the HDHMR sheet with 2 coats of white paint over a coat of approved zinc chromate primer. The approximate size of rubber wood frame is 75mm(wide)x 43mm ( builtup section using combination of 25mm+18mm) (thickness). The soft board shall

**Signature of Tenderer with Seal**

be wrapped with approved colour fabric of minimum 120 GSM and tightly tucked using proper adhesive of minimum cloth width of 300mm. The soft board shall be fixed to wall using approved SS M-6/polyamide fasteners anchor fastener of approved make/ heavy quality key hole hanger plate ( 6 Nos), including PU polish mat finish for finger joint rubber wood frame after surface preparation on all exposed areas, sealers, cost of labour, wastages, adhesive, Nails/S.S screws etc., all as directed by EIC

7. Writing board for Connecting Corridor: Providing, supplying and fixing in position GRE/ PolyVision e3 Ceramic Steel Belgium make Vitreous enamel antiscratch steel magnetic writing chalk board of 0.8mm thick made of Green - 6500, Slate-6502, Blue-5603 writing surface pasted on 8mm MDF with backing of 0.5mm thick GI sheet all as directed by EIC. The approximate sizes writing board shall be 2450mmx1200mm, 3200mmx1200mm and 2750mmx1200mm. The writing board shall be provided with around frame using finger jointed builtup rubber wood frame of finished size 75mmx 43mm ( builtup section using combination of 25mm+18mm) (thickness) including 90mm x 18 mm thick chalk holder floating panel at bottom of the board with 25mm x 10mm rubber wood beading on its facia including including PU polish mat finish for finger joint rubber wood frame after surface preparation on all exposed areas, sealers, cost of labour, wastages, adhesive, Nails/S.S screws necessary hardware etc., complete all as directed by EIC

8. Modular Toilet Cubicle: Providing, Fabricating and erecting Modular toilets formed out compact laminate panels of Merino or approved equivalent make with all accessories including SS pedestals, SS channel at top and wall end etc., The front total width of the partition is 1805mm and middle partition is 1215mm. The quoted rate shall include the cost of partition, door and door hardware as per specifications, drawings etc., all as per manufacturer specification and as directed by EIC.

9. Lockers for sports complex : Providing and fixing high pressure laminate lockers in tier/column system assembled in a sequence pattern as per the standards of M/s Merino OR M/s. Greenlam OR customised to size as per site condition in a similar arrangements of approved shade laminate finish of approximate sizes as per the following including standard skirting all as per manufacturer specification and tire system arrangement .Each shutter shall be provided with approved quality fittings & fixtures like hinges, partition supports, locks , number plate handle etc., all as per manufacturer specifications.

10. Supply & fixing all types of Structural steel fabrication work for the following using M/s. Sail OR M/s.Tata welded, riveted, bolted in built up sections for spiral stair case, railings and framed work suspenders, supports, portals frames etc., for spiral stair case & railing following at all floors and locations, heights, including scaffolding, bracing, multi-level staging, lead etc., gazettes plate, base plate etc. Using specified structural steel sections like angles, tees, flats, bars, chequered plates, sheets Channel/I sections tubes section/pipes, joists, bolts & nuts,M.s rods, threaded U/J bolts, washers, suitable size anchor fasteners of M/s Hilti or approved make for concrete and masonry, drilling holes in concrete & masonry etc., including supplying, cutting, fabricating,welding, bending to shape,( curved), wastages, hoisting/ erecting, fixing in position, making holes/chases wherever required and fixing /embedding in position in concrete/brick work with necessary hold fasts/ supporting plates, cleats, gazette plate, screws & rawl plugs and finishing the concrete/ brick work after fixing/ embedding including painting one coat Zinc chromate primer over shop coat of approved anticorrosive primer and two coats of synthetic enamel paint of approved make and colour on all exposed surfaces over a coat of approved steel primer etc. Complete as per specifications, drawings and as directed by EIC.

11. Supplying, fabricating and fixing in position at all floors integrated approved silver anodized aluminium section/ profiles [extruded]/slim profile sections with 20micron natural aluminium anodizing for all types of aluminium toughened glazed partition works for office/fixed partitions, as per drawing of approved manufactures with extruded sections of Jindal /Hindalco/Ecube and glass of M/s. Saint Gobain or Asahi etc., including wastages if any, conforming to relevant I.S specifications all as shown in the drawing, including providing and fixing aluminium channel beading/glazing clips fixed with necessary aluminium anodized screws, grouting the gap with approved PUF/beaker rod and silicon sealant with all arrangements like weather strips, clips etc. to make them completely waterproof and free from rattling and all standard accessories like locks, handles, hinges, screws, floor springs, patch locks, S.S. fasteners, nails etc., complete generally as per drawings, specifications and all as directed by Engineer-in-charge.

**Signature of Tenderer with Seal**

## LETTER OF TRANSMITTAL

**FROM,**

**To,**  
The Centre Director  
ICTS-TIFR Campus,  
Shivakote,  
Bengaluru.

**Subject:** "Providing & Supply and fixing furniture's, Toilet cubicle and lockers and allied works for various facilities of ICTS-TIFR campus, Shivakote village, Hessarghatta Hobli, Bengaluru North."

**NIT NO.:** ICTS/TIFR/Civil/02/10/2025-26 dated: 31<sup>st</sup> Oct 2025

**Sir / Madam,**

Having examined the details given in tender notice and tender document for the above project, I/we hereby submit the relevant information,

1. I/We hereby certify that all the statements made and information supplied in the enclosed forms 'A' to 'G', Annexure 1 to 4 and other accompanying statements are true and correct.
2. I/We have furnished all information and details necessary for tender and have no further pertinent information to supply.
3. I/We submit the requisite certified solvency certificate and authorize person of **ICTS-TIFR, Bengaluru** to approach the bank issuing the solvency certificate to confirm the correctness there of individual, employers, firms and corporation to verify our competence and general reputation.
4. I/We undertake that, in competing for and if the award is made to us, in executing the above contract, we shall strictly observe the laws: 'Prevention of Corruption Act 1988' against fraud and corruption.
5. I/We agree that we will associate with specialized agencies for design of specialized works and our quoted rates are all inclusive of charges payable to such Associate Specialized agencies and we will not be paid anything extra for engaging these specialized agencies.
6. I/We submit the following certificates in support of our suitability, technical know-how and capability for having successfully completed the following projects along with prescribed format:

**Signature of Tenderer with Seal**

<b>Sl. No.</b>	<b>Name of work</b>	<b>Certified by/from</b>
1		

- Enclosures:**
- 1) Forms A to G,
  - 2) Annexures (1 to 4)
  - 3) Company Profile

**Signature(s) of Applicant(s) :**

**Seal of Applicant**

**Signature of Tenderer with Seal**

**FORM – ‘A’**  
**FINANCIAL INFORMATION**

**I. Financial Analysis** – Details to be furnished duly supported by figures in balance sheet/profit and loss account for the last five years duly certified by the Chartered Accountant, as submitted by the applicant to the Income Tax Department (copies to be attached).

Particulars	Financial Year				
	20 – 21	21 – 22	22 – 23	23-24	24-25
i. Gross Annual turnover on construction work. (In Lakh)					
ii. Profit / Loss					
iii. Certified by					
iv. Annual Turn over					

**II Financial arrangements for carrying out the proposed work**

**III The following certificates are enclosed:**

- (a) Current Income Tax Clearance Certificate / Profit & Loss account as submitted to income tax officer.
- (b) Latest Solvency Certificate from bankers of Applicant.
- (c) Copy of the PAN card to be submitted
- (d) GST registration certificate.
- (e)

Signature of Chartered accountant with seal

**Signature of Tenderer with Seal**

## FORM -B

### DETAILS OF SIMILAR WORKS COMPLETED DURING THE LAST SEVEN YEARS ENDING 31.03.2025

Sl No	Name of the work /project and location	owner of sponsoring organization	Cost of work	Date of commencement as per the contract	Stipulated date of completion	Actual date of completion	Litigation arbitration pending / progress in detail	Name & Address / Phone no of officer to whom reference may be made.	Remarks
1									
2									
3									
4									
5									
6									
7									

\*Indicate gross amount claimed and amount awarded by the Arbitrator

Note : Applicant may submit separate form for giving details of work ( Completed ) for each year to fill up the details as above. Separate sheets if any shall be numbered.

**Signature of Tenderer with Seal**

**FORM –C**  
**DETAILS OF THE PROJECTS UNDER EXECUTION / AWARDED**  
**RECENTLY**

Sl No	Name of the work /project and location	owner of sponsoring organization	Cost of work	Date of commencement as per the contract	Stipulated date of completion	Actual date of completion	Litigation arbitration pending / progress in detail	Name & Address / Phone no of officer to whom reference may be made.	Remarks
1									
2									
3									
4									
5									
6									
7									
8									

Note : Applicant may submit separate form for giving details of work ( Completed ) for each year to fill up the details as above . Separate sheets if any shall be numbered

**Signature of Tenderer with Seal**

**FORM -D**  
**PERFORMANCE REPORT OF WORKS REFERED TO IN FORM 'B' & 'C'**

1.Name of work/Project & Location	
2.Agreement No.	
3.Estimated Cost	
4.Tendered Cost	
5. Stipulated contract period	
6. Date of start	
(i) Stipulated date of start	
(ii)Actual date of start	
7.Date of completion	
(i) Stipulated date of completion	
(ii)Actual date of completion	
8.Amount of compensation levied for delayed completion, if any.	
9.Amount of reduced rate items, if any.	
10. Performance Report.	
(a) Quality of work	Very Good / Good / Fair /Poor
(b) Financial soundness	Very Good / Good / Fair /Poor
(c) Technical Proficiency	Very Good / Good / Fair /Poor
(d) Resourcefulness	Very Good / Good / Fair /Poor
(e) General behaviour	Very Good / Good / Fair /Poor

Dated :

Executive Engineer or equivalent  
Signature & seal

Note : The same shall be accompanied by copy of work order and completion certificate issued by the client .

**Signature of Tenderer with Seal**

**Form –E**  
**STRUCTURE & ORGANISATION**

1	Name & Address of the applicant with Telephone No./Fax No./ Email ID	
2	a. Year of Establishment B.Date & Year of commencement of practice.	
3	Legal status of the applicant (attach copies of original document defining the legal status).	
	Status	
	a) An Individual	
	b) A proprietary firm	
	c) A firm in partnership	
	d) A limited company or Corporation / Jointventure / Consortia	
4	Names of Directors & other executives with designation	
5	Designation of individuals authorized to act for the organization.	
6	Total No. of professional staff (In house) : a) Civil Engineers b) Structural Engineers & Quantity Surveyors c) PHE Engineers & Fire Fighting d) Electrical Engineers e) IT Engineers f) Mechanical Engineer / HVAC g) Construction supervision staff (including Safety Engineer) h) Project Managers and Quality Assurance Engineers	
7	Was the applicant ever required to suspend the project for a period of more than six months continuously after you commenced the planning? If so, give the name of the project and reasons of suspension of project.	
8	Has the applicant or any partner in case of partnership firm, ever abandoned the awarded project before its completion? If so, give name of the project and reasons for abandonment.	
9	Has the applicant or any constituent partner in case of partnership firm, ever been debarred/black listed for competing in any organization at any time? If so, give details.	
10	Has the applicant or any constituent partner in case of partnership firm, ever been convicted by a court of law? If so, give details.	
11	In which field of Civil Engineering & MEP works the applicant has specialization & interest	
12	Enlistment with Government / Private bodies	

**Signature of Tenderer with Seal**

13	Department & Place of registration & Registration No 1 2 3 4	
14	Names and Titles of Director & Officers with designation proposed to be deputed on this work	
15	Designation of individuals authorized to act for the organization	

**Signature of Tenderer with Seal**

**Form – F**  
**TECHNICAL-QUALIFICATION ASSESMENT SUMMARY**

1	Name of the firm					
2	<b>Annual turnover:</b> Annual turnover during the last five years ending 31 <sup>st</sup> March 2025 shall be 100% of the estimated cost	20 – 21	21 – 22	22– 23	23-24	24-25
3.	Average annual turn over					
4	<b>Profit &amp; Loss:</b> Not having incurred any loss in two years or more during last five years ending 31/3/2025					
5	<b>Solvency Certificate:</b> Minimum @ 40 % of the estimated cost (Rs.7.56 lakhs)					
6	<b>Work Experience:</b> The contractor shall have experience of successfully completing Three ** similar composite works, each of value not less than 40% of the estimated cost of work or Two similar composite works each of value not less than 60% of estimated cost of work or One similar composite work not less than 80 % of the estimated cost of work during the last seven years ending March-2025					
a)	Client					
b)	Name of the work					
c)	Value of work					
d)	Description of work					
e)	Date of award					
f)	Date of completion					
g)	Details of work order / completion certificate					
h)	Whether all Pre- qualification criteria met	Yes / No				

**Note:**

Work orders and completion certificates from clients for the above-mentioned works shall be provided. In the absence of above documents, the details furnished shall be ignored. In case of collaboration, the above details shall be furnished for each party separately.

**Signature of Tenderer with Seal**

## **FORM G**

### **Bid Securing Declaration**

**(to be submitted on company's letter head)**

I/We the undersigned hereby declare that if we withdraw or modify the bids during the period of its validity, or if we are awarded the contract and fail to sign the contract, or to submit a performance security before the deadline defined in the request for bid document or fail to execute the contract, we will be suspended for the period of time specified in the request for bids document from being eligible to submit bids for contracts with the entity that invited the bids.

**Name and Signature of Authorized Signatory  
and Company Seal**

**Signature of Tenderer with Seal**

## Financial Bid Schedule of Quantities

SI No.	Description	Unit	Qty
1	Providing and fixing modular furniture viz, storage unit, wall unit/ under/above counter storage boxes/liner storage box, cupboard etc., for the following with open and close type, with & without shutter, at all heights in all floors etc., using 16 mm approved quality marine calibrated plywood as per latest revision of IS- 710 of M/s. Kit ply /M/s Merino/M/s. Century/M/s. Greenlam for all-round boxing, shutter, shelves and frame with approved colour and make 0.80mm thick laminate of approved shade for the entire storage/boxing unit and shutter (External /internal surfaces) properly framed and jointed, including labour charges approved brand hardware's, locking arrangement, etc complete, including cost of labour for fixing building hardware like concealed handle 150mm/100mm profile handles, Magnetic catch, soft closing box/cabinet hinges, Speciality locks of M/s. Ebco matching with Secu Rite cupboard lock with brass keys (P-SRC-20B) etc., complete as per specifications including providing and fixing edge binding with 2 mm thick of M/s. Rehau or M/s. LG PVC lipping of suitable width on all cut edges, wooden plugs, SS star headed screws, nails, etc., complete with all lead and lift all as directed by EIC.		
	<b>Note :</b>		
	1.All furniture's shall be modular type with customised to sizes as per the actual dimension available at site for each unit.		
	2. Quoted rate shall be inclusive of all fittings & fixtures/ accessories & wastages.		
	3. Quoted rate shall hold good for furniture's of all shapes & sizes in straight/curvilinear and any geometric shape.		
	4. Fixing of storage units shall be using M-8/M-10 size wherever required of M/s Wurth/ M/s Hiliti including drilling holes in concrete/ masonry wall unless other wise specified.		
	<b>Lab Furniture</b>		
1.01	<b>Floor storage drawer and open shelf unit</b> : Shall be of approximate size 850mm W x 400mm D x 1690mm height made out of 16mm thick marine board conforming to IS 710. All the edges of the storage shall have 2mm thick PVC edge bind. The storage unit shall consist of 2 drawer units of height 500mm each with bottom/undermount telescopic slider remaining with equal openable shelves of equal height as detailed including 2 in 1 lock, 150mm aluminium concealed handle, anchored to wall using approved SS anchor fasteners -6 Nos etc, complete as per drawings and specifications and as directed by Engineer- In-Charge.	Sqm	1.45
1.02	<b>High wall storage</b> of approximate size 1800mm(W) X 1000mm(H)x450mm (D) and 1700mm(W) X 1000mm (H) 450mm(D)1wall Storage unit shall be with 2 horizontal and 4 Nos of vertical partition in combination 2 supports fixed back to back for fixing door shutter with box hinges. All the 6 openable shutter of equal size for 3 compartments of approximate with of 600mm/566mm wide including fixing the unit with SS anchor fastener of size M-8 of M/s Wurth/ M/s Hiliti all fittings and fixtures with Speciality locks of M/s. Ebco matching with Secu Rite cupboard lock with brass keys (P-SRC-20B) all as per the drawing and as directed by EIC.	Sqm	3.50

**Signature of Tenderer with Seal**

1.03	<b>Floor mounted storage unit with sliding shutter</b> : Providing & supplying open storage unit of approximate size 1500mm (L) x 600mm (D) x750(H), with two internal horizontal shelves with three equal compartment and 4 Nos of vertical support s per the drawing. The storage unit shall have two equal size sliding shutters guided over Ebco sliding system. The sliding shutters shall be 16mm thick ply shutter etc., complete as per the specifications.	Sqm	1.13
1.04	<b>Open type high wall storage Unit:</b> The approximate size of the storage is 3000mm(W) x 1000/1200mm/450mm(D) . The wall Storage unit shall be provided with 1 no horizontal shelf and 2 Nos of vertical support placed at equal distant etc., all per drawing & as directed.	Sqm	3.00
1.05	<b>Floor mounted storage Unit</b> : Providing and fixing vertical support & shutter for existing undercounter storage unit of approximate size of 2400mm x 800mm height and 750mm deep. The shutter shall be made using 16mm marine plywood confirms to IS 710 approved laminate and standard hardware as per the functional requirement. Providing 3 Nos of builtup vertical support with 2 ply back to back for full depth and 6 Nos of openable shutter as per the actual site measurements. Each door shutter shall be provided with 2 Nos of soft closing hinges, 150mm height concealed handles, 2 Nos of tower bolt for double door shutter system, Speciality locks of M/s. Ebco matching with Secu Rite cupboard lock with brass keys (P-SRC-20B) etc., all as directed by EIC. <b>Note : Shutter to be made as per the actual size of the existing storage unit.</b>	Sqm	2.00
1.06	<b>CRECHE : Floor mounted Open storage unit</b> :Providing & supplying open storage unit of approximate size 2460mm(W) X 920mm (H) x 700mm(D) with one number vertical partition without shutter, including to anchoring to back wall M6 polyamide anchor fasteners - 6 Nos of approved make etc., all as directed by EIC.	Sqm	2.30
1.07	<b>CRECHE : Floor mounted vertical storage unit:</b> Cupboard unit of approximate size 1200mm(W) x 450mm(D) x 2400mm height with 3 middle vertical partition and 5 numbers horizontal at equal distance (total 18 storage space for the entire. Each cabinet shutter shall be provided with 4 no's SS 304 grade soft closing hinges of M/s. EBCO make of HSM 1-M1SS/HSM 2-M1SS with SS screws and 150mm long concealed profile handle and other standard accessories, including to anchoring to back wall M6 polyamide anchor fasteners - 6 Nos of approved make all as per the specification and as directed by EIC.	Sqm	2.90
	<b>Directors Office</b>		
1.08	Floor mounted storage unit :Providing & supplying cupboard unit of approximate size 860mm(W) X 450mm(D) x 2100mm height. The unit shall be provided with two no's equal size glazed shutters and 4 number of equal horizontal adjustable shelves and 1 No vertical support The cabinet shutter shall be provided with 3 no's SS 304 grade soft closing hinges for each shutter of M/s. Ebco make of HSM 1-M1SS/HSM 2-M1SS with SS screws and 150mm long concealed profile handle,including to anchoring to back wall M6 polyamide anchor fasteners - 6 Nos of approved make all as per the specification and as directed by EIC.	Sqm	1.81
	<b>A 305 office.</b>		

**Signature of Tenderer with Seal**

1.09	Providing, supplying and fixing glazed shutter using 16mm thick plywood/HDHMR sheet for the existing storage of approximate size 1970mm(L) x 580mm(H) and 2400mm(L) x 580mm(H) with approved laminate and hardware. The glazed Shutter shall be of equal a size in 2 Nos with intermediate vertical support equally placed including suitable size teak wood beading around the glass on both sides and polishing the teak wood beading to match with the laminate. The thickness of glass shall be 4mm. Each shutter shall be provided with 3 Nos soft closing cabinet hinges, including providing approved locking arrangement conforming to Speciality locks of M/s. Ebco matching with Secu Rite cupboard lock with brass keys (P-SRC-20B) approved make as per detailed drawing and as directed by EIC.		
1.09 (a)	Existing storage unit of approximate size 1970mm(L) x 580mm(H) with 2 Nos of built up vertical support palced back to back and 6 Nos of glazed shutter etc., all as directed by EIC.	Sqm	1.10
1.09 (b)	Existing storage unit of approximate size 2400mm(L) x 580mm(H) with 3 Nos of built up vertical support placed back to back and 8 Nos of glazed shutter etc., all as directed by EIC.	Sqm	1.40
<b>A306 Below window</b>			
1.1	<b>Floor mounted storage unit :</b> Providing & supplying The approximate floor storage unit of size 2000mm(wide)x 270mm (depth)x700mm( height) made out of minimum 16mm thick marine ply confirming to IS 710 for book shelf with 6 Nos of glazed shutter back to back, 2 Nos of vertical support and 1 No horizontal shelf. The glazed shutters shall have 75mm wide top bottom and vertical styles and 150mm tower bolt at top & bottom for 3 shutters and 3 Nos specified lock. The thickness of glass shall be 4mm. Each shutter shall be provided with 2 Nos soft closing cabinet hinges etc., all as per detailed drawing and as directed by EIC.	Sqm	1.50
1.2	<b>Over Head storage unit - Outreach office :</b> Providing & supplying over head storage combination unit of approximate size 2050mm (L) x 600mm(H) x 450mm(D) - <b>2 units</b> and 500mmx600mmx450mm - <b>1 unit</b> The storage unit shall be provided with 1 intermediate Horizontal shelf and 2 openable double shutter and 1 openable sutter system of equal width for each storage unit. The unit shall be provided with 1 vertical built up support back to back and 3 single intermediate vertical support. for each storage unit. All component shall be of equal width. The centre portion of 600mm shall be closed with front facia built up panel with 3 ply joined back to back. The storage unit shall be fixed to masonry wall using SS/Polyamide anchor fastener of size M-8 ( 8 Nos) of M/s Wurth/ M/s Hiliti all fittings and fixtures etc., all as per the drawing and as directed by EIC.	Sqm	2.80
1.3	<b>Over Head storage unit - Academic &amp; programme office : - L" shape unit</b> Providing & supplying over head storage unit of approximate size 2400mm (L) x 900mm(H) x 450mm(D) and 1400mmx900mmx450mm - 2 units each as per the following :		

**Signature of Tenderer with Seal**

1.3 (a)	Providing & supplying over head storage unit in combination of 2 units of approximate size 1200mm (L) x 900mm(H) x 450mm(D) height- 2 Nos with 3 equal compartments. Each compartments shall be provided with 2 openable shutters. The storage unit shall be provided with 1 Horizontal shelf. The unit shall be provided with 2 vertical support with 2 ply jointed back to back. All component shall be of equal width. Each shutter shall be provided with 2 Nos of soft closing hinges, 150mm size concealed handle including providing "L" shaped foldable door for corner space. The storage unit shall be fixed to masonry wall using SS/Polyamide anchor fastener of size M-8 of M/s Wurth/ M/s Hiliti all fittings and fixtures etc., all as per the drawing and as directed by EIC.	Sqm	4.32
1.3 (b)	<b>Over Head storage unit - Academic &amp; programme office :</b> Providing & supplying over head storage unit of approximate size 1400mm (L) x 900mm(H) x 450mm(D) height with 2 equal compartments. Each compartments shall be provided with 2 openable shutters. The storage unit shall be provided with 1 Horizontal shelf. The unit shall be provided with 2 vertical support with 2 ply jointed back to back. All component shall be of equal width. Each shutter shall be provided with 2 Nos of soft closing hinges, 150mm size concealed handle. The storage unit shall be fixed to masonry wall using SS/Polyamide anchor fastener of size M-8 of M/s Wurth/ M/s Hiliti all fittings and fixtures etc., all as per the drawing and as directed by EIC.	Sqm	2.52
2	Providing, supplying and fixing storage units/ open display shelves unit, storage boxes, cupboard etc., for the following at all heights & floors etc., using 25mm/18mm/12mm finger jointed first quality natural rubber board of approved brand & quality without any knots and black patches for all-round boxing, shutter, shelves and frame properly framed and jointed using wooden dowel/ plug of required sizes and dovetail joint with approved quality adhesive, Fevicol, approved brand hardware's/ fitting & fixtures ,locking arrangement, under count telescopic drawer channel, soft closing hinges, wooden knob and leg made to required profile and size from the same board, cut to size etc complete, including cost of labour for fixing building hardware like concealed handle 150mm/100mm profile handles for each shutter, Magnetic catch, Speciality locks of M/s. Ebco matching with Secu Rite cupboard lock with brass keys (P-SRC-20B) etc., complete as per specifications including polishing all internal & external surfaces including preparing the surface, applying a coat of sealer, 3 coats of neutral polish and final satin melamine spray finish SS star headed screws, nails, etc., complete with all lead and lift etc., all as per drawing and as directed by EIC. <b>Note : (1) The thickness of board for vertical partition/support and horizontal shelves shall be minimum 18mm thick finger jointed rubber board unless otherwise specified. (2) The door shutter for storage units etc., shall have 75mm wide vertical, horizontal, middle and lock rail unless otherwise specified.</b>		
	<b>Sports Complex :</b>		

**Signature of Tenderer with Seal**

2.1	<b>Floor mounted unit</b> : Providing, supplying and fixing storage unit of approximate overall size of 900mm(W) x 500mm (D) x 2100mm (H) and comprising of two components. The upper part is 1400mm height and lower part is 700mm height made from minimum 18mm thick finger jointed rubber wood natural board for sides, top & bottom and back board shall be 12mm thick board. The unit shall have one intermediate vertical partition for top portion of 1400mm height. Total 4 Nos of horizontal shelf of full width, out of which one set is fixed back to back as per the drawing and 2 Nos of shelf with half width. The upper part of glazed Shutter shall be equal in size in 2 Nos & lower part with 18mm thick shutter. Top shutter has vertical style, top, bottom & lock rail of 75mm wide. Required size rebate /groove to be made in the vertical and horizontal style of shutter for fixing 4mm glass and providing beading with same material around the glass for fixing the glass. The thickness of glass shall be 4mm. Each shutter for portion shall be provided with 3 Nos of soft closing box hinges. Each shutter of bottom portion shutter with 2 Nos of soft closing cabinet hinges, concealed handle for each shutter, profiled leg 75mm height, wooden knob made from same material/150mm size concealed handle - 4 Nos, including providing approved locking arrangement conforming to Speciality locks of M/s. Ebco matching with Secu Rite cupboard lock with brass keys (P-SRC-20B) approved make and polishing the unit as explained above and as per detailed drawing and as directed by EIC.	Sqm	1.90
2.2	<b>Floor mounted unit</b> :Providing, supplying and fixing open storage unit of approximate size of 970mm(wide)x 450mm (depth)x2220mm( height) made from finger jointed rubber wood board of 18mm thick for sides, top & bottom and back board shall be 12mm thick, with 2 intermediate vertical partition/support 1000mm above floor and 1 vertical partition up to 1000mm height. The upper and lower part of storage unit shall be provided with 3 Nos of adjustable horizontal shelves respectively including providing edge beading of size 10mmx 10mm made from same material for the shelves edges as per the drawing and polishing as specified above etc., all as per detailed drawing and as directed by EIC.	Sqm	2.15
2.3	<b>Floor mounted unit</b> : Providing & supplying storage unit of approximate size 800mm(W) x 450mm (H) x 450mm(D) made from finger jointed rubber wood board of 18mm thick for sides, top & bottom and back board shall be 12mm thick with one intermediate horizontal support. The storage unit shall be provided with 1 No horizontal shelves using 18mm finger jointed board and two numbers of drawers of height 150mm made from 12mm thick board for sides, back and bottom. with SS telescopic channel. The front face of the drawer shall be 18mm thick board. The legs to be profiled to shape & 75mm height. Front part of drawer shall be extended by 25mm more to act as handle with all fittings & fixture, approved locking arrangement - 2 Nos conforming to Speciality locks of M/s. Ebco matching with Secu Rite cupboard lock with brass keys (P-SRC-20B) approved make and polishing the unit as explained above and as per detailed drawing and as directed by EIC.	Nos	1.00
3	Providing, supplying finger jointed approved quality rubber wood panel board of size 2400mm x1200mm of following thickness including transportation at all leads all as directed by EIC.		
3.1	25mm finger jointed rubber wood board	Nos	2.00
3.2	12mm finger jointed rubber wood board	Sqm	2.88

**Signature of Tenderer with Seal**

4	<p><b>Table &amp; seating bench:</b> Providing, designing and making built up section using 25mm thick finger jointed rubber wood board for Table top &amp; bench top as per the approximate sizes <b>1050mm x 1050mmx750 - 2 Nos, 750mm x 750mm- 2 Nos and seater is 1050mm x 450mm - 4 Nos and 750mm x 450mm - 4 Nos.</b> in square /rectangular or any geometric shape symmetrical/ asymmetrical design or any approved shape at all leads &amp; heights etc., fixed on SS tubular frame ( which will be paid under separate item) SS screws, including providing 100mmx25mm wide additional member around to given appearance of 50mm thick and tapered slope to inside as shown in drawing including PU polish finish after surface preparation on all exposed areas, sealers, cost of labour, wastages, adhesive, Nails/S.S screws etc., complete as per the detailing &amp; as specified etc., all directed by EIC.</p>	Sqm	9.81
5	<p><b>SS frame work :</b> Providing, supplying fabricating SS frame work for table and bench support and kitchen storage rack, SS frame for refrigerator support, using hollow tubes/ flats/ angle using SS 304 grade profile of M/s Zindal / M/s JSW to required size including finishing all the welded joints, providing 5mm thick plate lugs with hole at all corners and intermediate support members for fixing top wooden planks, M6/M8 size Levelling Screw Set of 4 Nos/ heavy duty adjustable furniture leg Leveller with SS nuts one welded to frame bottom, SS washer, cover plate for legs etc., complete as per the detailing &amp; as specified etc., all directed by EIC. Note : (1) <b>The approximate sizes of frames for table is 900mm x 900mm - 2 Nos,600mm x 600mm- 2 Nos and seater is 900mm x 300mm - 4 Nos and 600mm x 300mm - 4 Nos.</b></p>	Kg	40.00
6	<p><b>Soft pinup board :</b> Providing ,supplying and fixing pinup board of approximate size 2.40mts x 1.2mt using 12mm thick soft fibre board glued over 4mm thick water proof HDHMR sheet fixed in level with finger jointed rubber wood frame making a rebate of 4mm at back and painting the HDHMR sheet with 2 coats of white paint over a coat of approved zinc chromate primer. The approximate size of rubber wood frame is 75mm( wide)x 43mm ( builtup section using combination of 25mm+18mm) (thickness). The soft board shall be wrapped with approved colour fabric of minimum 120 GSM and tightly tucked using proper adhesive of minimum cloth width of 300mm. The soft board shall be fixed to wall using approved SS M-6/polyamide fasteners anchor fastener of approved make/ heavy quality key hole hanger plate ( 6 Nos), including PU polish mat finish for finger joint rubber wood frme after surface preparation on all exposed areas, sealers, cost of labour, wastages, adhesive, Nails/S.S screws etc., all as directed by EIC. <b>Note : (1)</b> Rubber wood frame will be measured and paid under relevant around . The ( Item No 3 above) <b>(2)</b> Actual size of the soft board will be measured for payment. <b>(3)</b> Finger jointed rubber wood will be supplied by department free of cost.</p>	Sqm	8.70

**Signature of Tenderer with Seal**

7	<b>Writing board for Connecting Corridor:</b> Providing, supplying and fixing in position GRE/ PolyVision e3 Ceramic Steel Belgium make Vitreous enamel antiscratch steel magnetic writing chalk board of 0.8mm thick made out of Green - 6500, Slate-6502, Blue-5603 writing surface pasted on 8mm MDF with backing of 0.5mm thick GI sheet all as directed by EIC. The approximate sizes writing board shall be 2450mmx1200mm, 3200mmx1200mm and 2750mmx1200mm. The writing board shall be provided with around frame using finger jointed builtup rubber wood frame of finished size 75mmx 43mm ( builtup section using combination of 25mm+18mm) (thickness) including 90mm x 18 mm thick chalk holder floating panel at bottom of the board with 25mm x 10mm rubber wood beading on its facia including including PU polish mat finish for finger joint rubber wood frme after surface preparation on all exposed areas, sealers, cost of labour, wastages, adhesive, Nails/S.S screws necessary hardware etc., complete all as directed by EIC. <b>Note :</b> (1) Rubber wood frame will be measured and paid under relevant around . ( Item No 3 above) (2) Actual size of the writing board will be measured for payment. (3) Finger jointed rubber wood will be supplied by department free of cost.	Sqm	10.10
	<b>Toilet Modular Cubicle</b>		
8	<b>Modular Toilet Cubicle:</b> Providing, Fabricating and erecting Modular toilets formed out compact laminate panels of Merino or approved equivalent make with all accessories including SS pedestals, SS channel at top and wall end etc., The front total width of the partition is 1805mm and middle partition is 1215mm. The quoted rate shall include the cost of partition, door and door hardware as per specifications, drawings etc., all as per manufacturer specification and as directed by EIC.	Compl ete unit	1
	<b>Note :</b>		
	(1)The system is a combination of One "L" partition and one face panel. Approximate size of "L" partition is 900mm x 1215mm with one door shutter opening out side and face panel is 900mm with one door shutter opening out side.		
	(2) Approximate size of the partition 1805mm x1215mmx2030mm.		
	(3) Rate shall be quoted for the total one combined unit of one partition between two toilet and One front panel with two shutters of standard size ( 600mm) along with all standard fitting & fixtures.		
	<b>Model Type:</b> Modular Cubicle - Titan SS series of M/s Merino OR /Classic series and Model Evergreen of M/ Greenlam Sturdo		
	<b>Partition thickness:</b> 12mm thick high pressure compact laminate.		
	<b>Size of cubicle:</b> "L: cubicle - 900mm (W)x 1280mm(D)x900mm and facia - 900mm (W)x 1980(H)		
	<b>Partition height:</b> 2030mm from FFL. Bottom stud is 90mm.		
	<b>Door size:</b> 610 mm (W) x 1790mm (H)		
	a) Coat hook		
	b) Privacy thumb turn		
	c) Hinges-gravity to close		
	d) Door knob		
	e) Height adjustable SS pedestal.		
	f) Top profile		
	g) U & F channel		

**Signature of Tenderer with Seal**

	<b>h) Occupancy indicator</b>		
9	<b>Lockers for sports complex</b> : Providing and fixing high pressure laminate lockers in tier/column system assembled in a sequence pattern as per the standards of M/s Merino OR M/s. Greenlam OR customised to size as per site condition in a similar arrangements of approved shade laminate finish of approximate sizes as per the following including standard skirting all as per manufacturer specification and tire system arrangement .Each shutter shall be provided with approved quality fittings & fixtures like hinges, partition supports, locks , number plate handle etc., all as per manufacturer specifications.		
	<b>Note</b> : (1) The number of lockers tier/column system arranged vertically on a locker frame system. The number of individual lockers/compartments are in one column/tier system varies with actual requirement as specified below.		
	(2) Hardware shall be SS316 grade with Steel Grey/Charcoal black in brush finish.		
	(3) Aluminium extrusion profile shall be with Steel Grey/Charcoal black. in Satin finish..		
9.1	1200mm (W) x 1898mm(H) x 465mm (D) - 4 tier/A4 system of equal width 4 columns and 4 Nos locker of equal size per column - <b>16 Nos Lockers</b>	Per Tier	4.00
9.2	2100mm (W) x 1898mm(H) x 425mm. (D) - 5 tier/A5 system of equal width 7 Nos of columns and 5 Nos lockers of equal size per column - <b>35 Nos lockers</b>	Per Tier	7.00
9.3	600mm (W) x 1898mm(H)) x 430m. (D) - 6 tier/A6 system of equal width 2 columns and 6 Nos of lockers of equal size per column - <b>12 Nos lockers</b>	Per Tier	2.00
	<b>Ladies washroom : General arrangement system</b>		
9.4	600mm (W) x 1898mm(H) x 375 (D) - 4 tier/A4 system of equal width 2 columns and 4 Nos of lockers of equal size per column - <b>08 Nos Lockers</b>	Per Tier	2.00
9.5	600mm (W) x 1898mm(H) x 465mm (D) - 5 tier/A5 system of equal width 2 Nos of columns and 5 Nos of lockers of equal size per column - <b>10 Nos lockers</b>	Per Tier	2.00
9.6	900 mm (W) x1898mm(H) x 465mm (D) - 6 tier/A6 system of equal width 3 columns and 6 Nos equal of lockers of equal size per column - <b>18 Nos lockers</b>	Per Tier	3.00
	<b>Note</b> : Rate shall be quoted for each tier/column system based on the number of lockers per tier/column. (Image is enclosed for reference)		

**Signature of Tenderer with Seal**

10	Supply & fixing all types of Structural steel fabrication work for the following using M/s. Sail OR M/s. Tata welded, riveted, bolted in built up sections for spiral stair case, railings and framed work suspenders, supports, portals frames etc., for spiral stair case & railing following at all floors and locations, heights, including scaffolding, bracing, multi level staging, lead etc., gazettes plate, base plate etc. Using specified structural steel sections like angles, tees, flats, bars, chequered plates, sheets Channel/I sections tubes section/pipes, joists, bolts & nuts, M.s rods, threaded U/J bolts, washers, suitable size anchor fasteners of M/s Hilti or approved make for concrete and masonry, drilling holes in concrete & masonry etc., including supplying, cutting, fabricating, welding, bending to shape, (curved), wastages, hoisting/ erecting, fixing in position, making holes/chases wherever required and fixing /embedding in position in concrete/brick work with necessary hold fasts/ supporting plates, cleats, gazette plate, screws & rawl plugs and finishing the concrete/ brick work after fixing/ embedding including painting one coat Zinc chromate primer over shop coat of approved anticorrosive primer and two coats of synthetic enamel paint of approved make and colour on all exposed surfaces over a coat of approved steel primer etc. Complete as per specifications, drawings and as directed by EIC.	Kgs	750.00
11.1	Supplying, fabricating and fixing in position at all floors integrated approved silver anodized aluminium section/ profiles [extruded]/slim profile sections with 20micron natural aluminium anodizing for all types of aluminium toughened glazed partition works for office/ fixed partitions, as per drawing of approved manufactures with extruded sections of Jindal /Hindalco/ Ecube and glass of M/s. Saint Gobain or Asahi etc., including wastages if any, conforming to relevant I.S specifications all as shown in the drawing, including providing and fixing aluminium channel beading/glazing clips fixed with necessary aluminium anodized screws, grouting the gap with approved PUF/beaker rod and silicon sealant with all arrangements like weather strips, clips etc. to make them completely waterproof and free from rattling and all standard accessories like locks, handles, hinges, screws, floor springs, patch locks, S.S. fasteners, nails etc., complete generally as per drawings, specifications and all as directed by Engineer-in-charge. <b>Note : Toughened glass will be measured and paid under relevant item.</b>	Kgs	200.00
	Note: (1) Shop drawings shall be submitted for approval.		
	(2) Quoted rate shall hold good for 180mm long aluminium powder coated two pairs of handle, 1 no lock for a door etc, complete.		
	(3) Quoted rate shall be inclusive protection film all-round till completion of erection & commissioning.		
11.2	Providing and fixing 5mm thick toughened approved make for the aluminium partition including EPDM gasket etc., all as directed by EIC.	Sqm	30.00

**Signature of Tenderer with Seal**

## ANNEXURE-1

### PRE-QUALIFICATION OF PRIME CONTRACTORS – PROFILE – DETAILS OF ORGANISATION

**NOTE:** Please enclose separate sheets, photographs, documents etc., wherever necessary.

1	Name of the Firm/Company	
2	Address	
3	3a) Telephone Nos. 3b) Mobile No. 3c) Fax No.	
4	Email ID	
5	Legal status of the application (Attach copies of original document defining the legal status) (Individual / partnership / incorporated company etc)	
6	Year of Establishment and place of establishment.	
7	Name of Partner/Directors and key Personnel in charge of construction site with designations.	
8	Bio-Data of Partners/Directors / Key personnel Details may be given in the enclosed format (Form A1)	
9	Particulars of registration with various Govt. bodies (attach attested photocopy)	
10	List of Technical Personnel Employed	
11	List of other Personnel Employed	
12	List of consultant engaged by the firm	
13	Banker's Name	
14	List of Sub-Contractors along with their details	
15	Address of Bangalore office if any	
16	Any other details not covered above regarding organizational structure / profile of contractors.	
17	Details of ISO Certification	

**Signature of Tenderer with Seal**

**ANNEXURE-2  
LITIGATION HISTORY**

**Name of applicant or partner in specialized agencies: -----**

Applicants, including each of the partners of a /specialized agencies, shall provide information on any history of litigation or arbitration resulting from contracts executed in the last ten years or currently under execution, as required in this Pre-Qualification document.

A separate sheet shall be used for each partner of a specialized agencies.

LITIGATION HISTORY					
Year	Name of client	Cause of Litigation	Matter under dispute	Award for or Against the Applicant	Disputed Amount
1					
2					
3					
4					
5					

Has the applicant ever defaulted or been declared in default on a contract?

Has the applicant ever been debarred, suspended, or otherwise prohibited from contracting with any Federal, State, or other government agency of entity?

Within the last ten years, has the applicant (including individual persons thereof) including any partner, been charged with, or convicted of, any serious crime of felony or for corrupt practice?

**Signature of Tenderer with Seal**



## ANNEXURE-4

### SITE INSPECTION REPORT

Name of the Agency:  
Address,

Contact No.  
Email Id:

**Ref: Name of work:** Providing & Supply and fixing furniture's, Toilet cubicle and lockers and allied works for various facilities of ICTS-TIFR campus, Shivakote village, Hessarghatta Hobli, Bengaluru North.

**NIT No:** ICTS/TIFR/Civil/02/10/2025-26 dated: 31<sup>st</sup> Oct 2025

We have visited the site and understand the scope of the work to participate in the tender and quote the rate accordingly as per the schedule (BOQ) of the above-mentioned work

Signature of the contractor

Certified that the above agency has visited the site.

Engineer -In- Charge.

**Signature of Tenderer with Seal**

## CHECKLIST

Following documents shall be submitted along with the Tender:

<b>SI No</b>	<b>Description of the document</b>	<b>Whether enclosed or not</b>
1	<b>Form –A</b> - Financial Information	
2	<b>Form –B</b> - Details of <b>works</b> of similar executed during last seven years ending 31.03.2025	
3	<b>Form –C</b> - Details of project under execution	
4	<b>Form –D</b> - Performance report of works referred to in Form-B &C	
5	<b>Form –E</b> - Structure & Organization	
6	<b>Form –F</b> - Technical evaluation assessment summary.	
7	<b>Form – G</b> – Bid Securing Declaration	
8	Annexure -1	
9	Annexure -2.	
10	Annexure -3	
11	Annexure -4	
12	Site Visit report.	
13	Drawings	

**Signature of Tenderer with Seal**

# Sketch 1.1

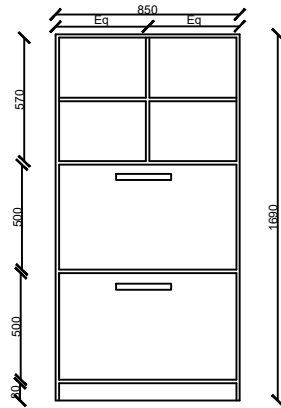

Approximately 850x1690x450mm deep with Open Shelf with 2 drawers.

# Sketch 1.2

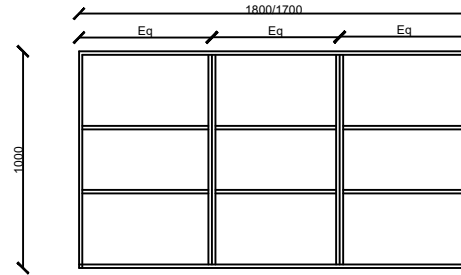

Approximately 1800/1700x1000x450mm high wall unit with 6 glazed shutters of equal size.

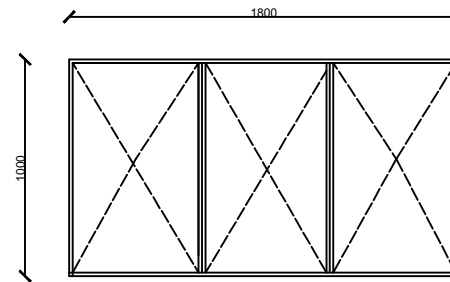

Front View

ICTS - TIFR  
Hessarghatta, Bengaluru.

Furniture Drawings

Drg No : F1-2025-R0

### Sketch 1.3

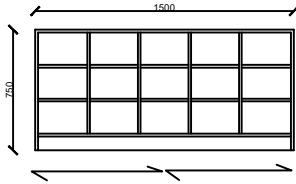

Approximately 1500x750x600mm with Sliding shutters of equal size.

### Sketch 1.5

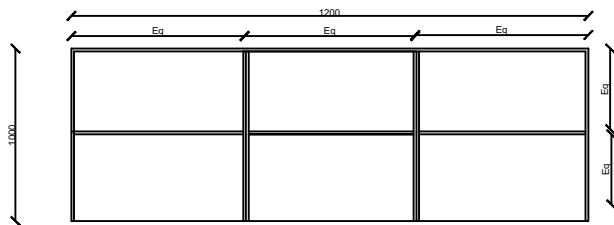

Approximately 1200x800x750mm deep under count Storage unit 2 Nos.

### Sketch 1.4

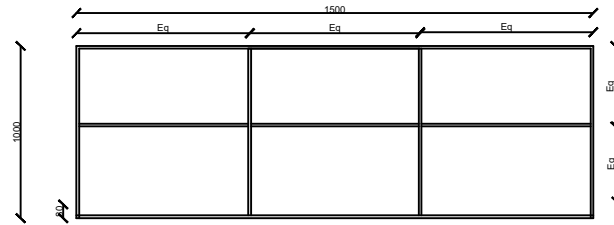

Approximately 1500x1000/1200x450mm open Storage unit 2 Nos.

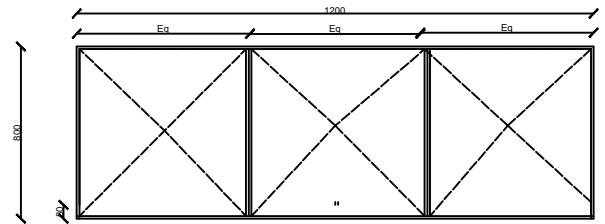

Front View

ICTS - TIFR  
Hessarghatta, Bengaluru.

Furniture Drawings

Drg No : F2-2025-R0

### Sketch 1.6

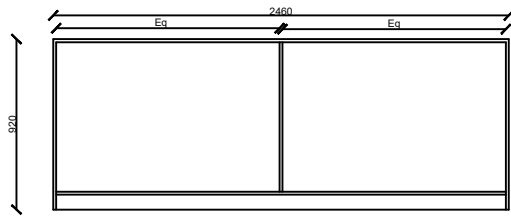

Approximately 2460x700mmx900mm open Storage unit.

### Sketch 1.7

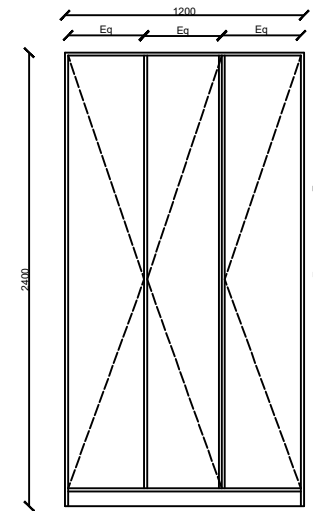
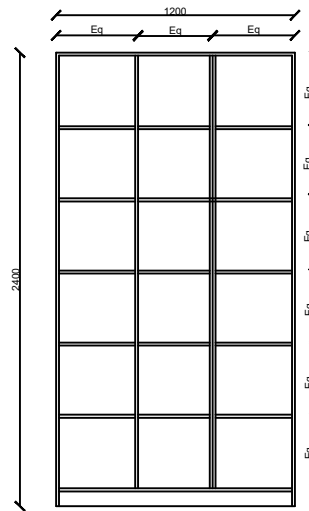

Front View

Approximately 2400x1200x450mm deep Storage unit with 3 equal sized complete ply shutter.

ICTS - TIFR  
Hessarghatta, Bengaluru.

Furniture Drawings

Drg No : F3-2025-R0

# Item No 4

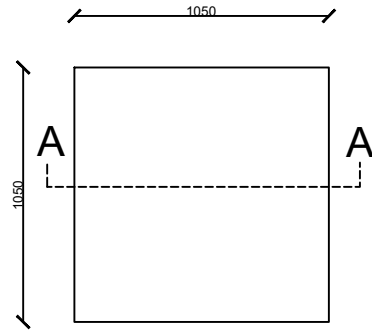

Top View

1050x1050x650mm - 2Nos

750x750x650mm - 4Nos

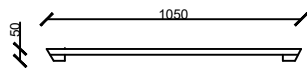

C/S at A - A

Seating Bench



1050x400x450mm - 8Nos

750x400x450mm - 8Nos

# Item No 5

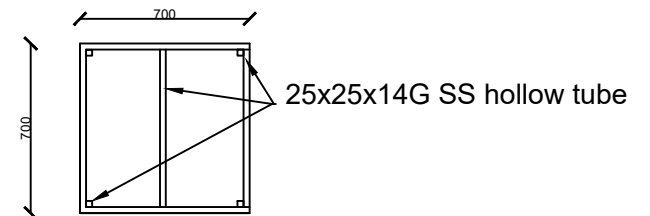
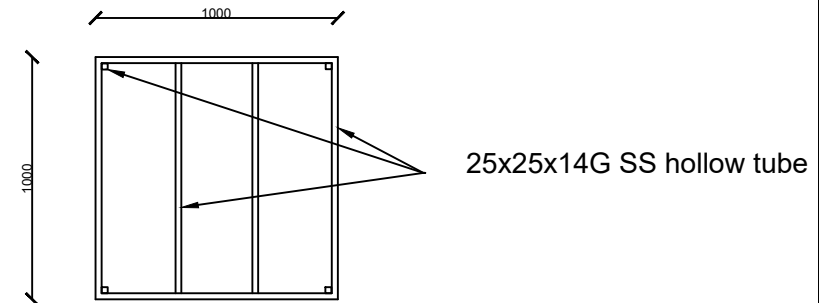
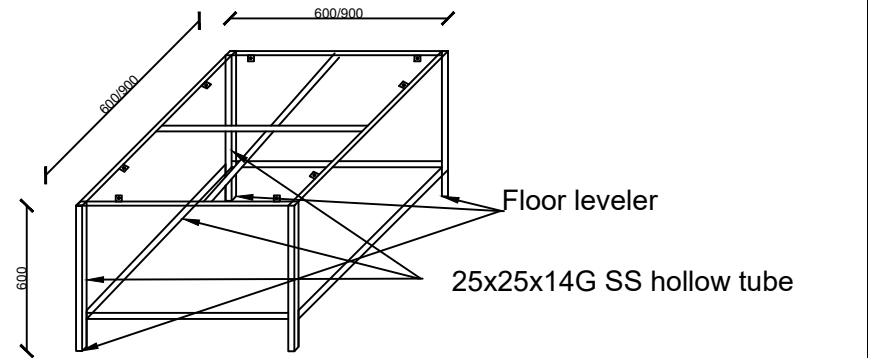

# Ladies Restroom

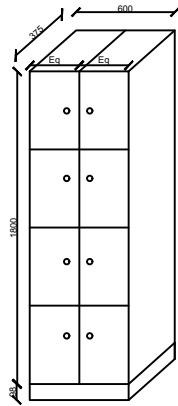

Tier 4 / A4 Locker - 8 Nos of lockers

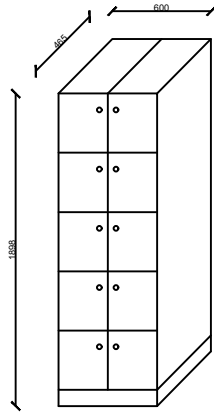

Tier 5 / A5 Locker - 10 Nos of lockers

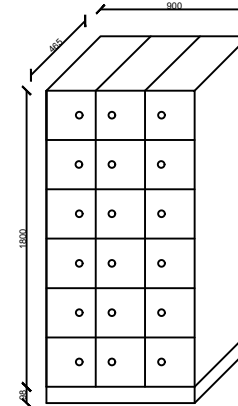

Tier 6 / A6 Locker - 18 Nos of lockers

# Gents Restroom

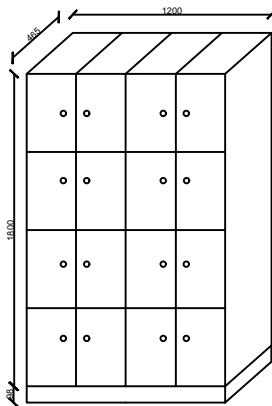

Tier 4 / A4 Locker - 16 Nos of lockers

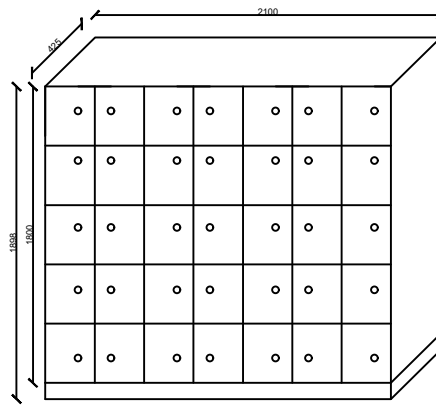

Tier 5 / A5 Locker - 35 Nos of lockers

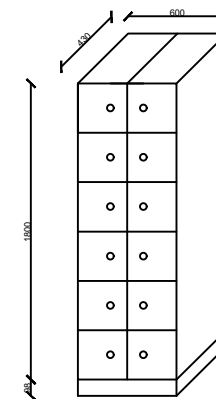

Tier 6 / A6 Locker - 12 Nos of lockers

## Sketch 1.8

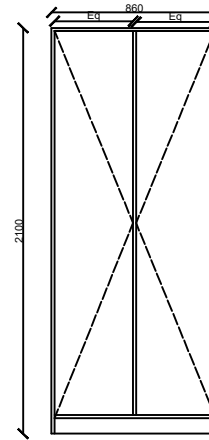
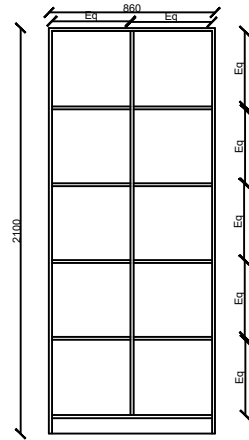

Approximately 860x2100x450mm deep Storage unit with 2 equal sized glazed shutter.

## Sketch 1.9 A

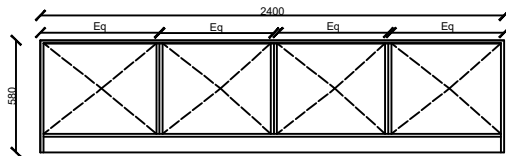

Approximately 2400x580x750mm deep under count Storage unit only for fixing glazed shutters.

## Sketch 1.9 B

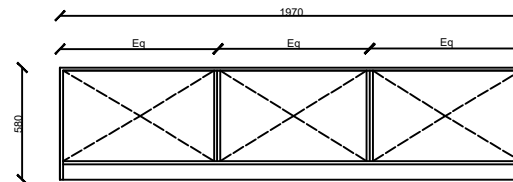

Approximately 1970x580x750mm deep under count Storage unit only for fixing glazed shutters.

## Sketch 1.10

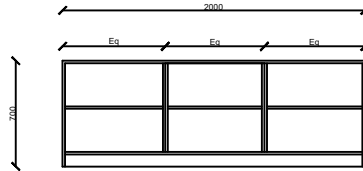

Approximately 2000x700x270mm deep under count Storage unit with glazed shutters.

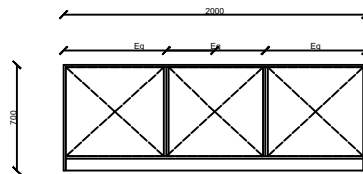

Front View.

## Sketch 1.11

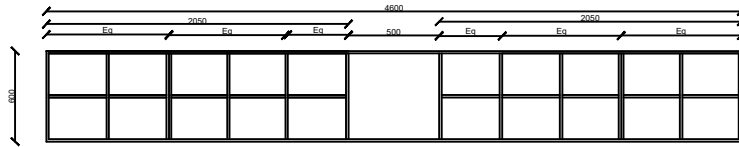

Approximately 4600mmx600x450mm deep high wall Storage unit .

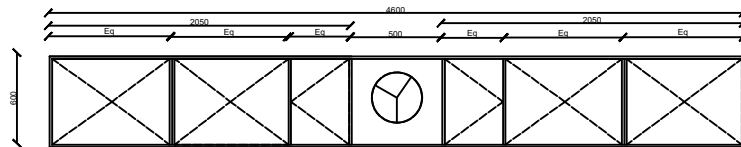

Front View.

### Sketch 1.12 (a)

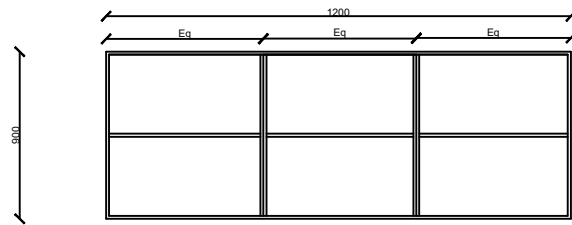

Approximately 1200mmx900x450mm deep high wall Storage unit  
2 Nos.

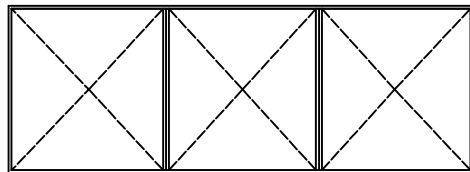

Front view with 6 equal sized shutters.

### Sketch 1.12 (b)

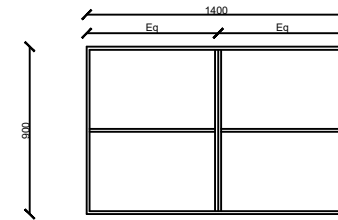

Approximately 1400mmx900x450mm deep high wall Storage unit.

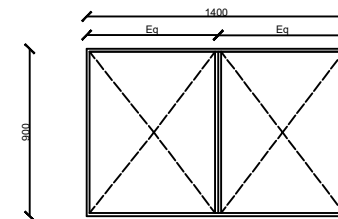

Front View

### Sketch 2.1

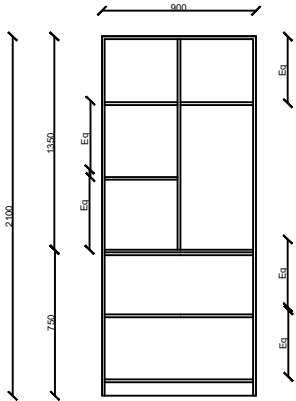

Approximately 900x2100x450mm deep Storage unit with 2 glazed shutters for top of the unit and 2 complete ply shutter for bottom shelves.

### Sketch 2.2

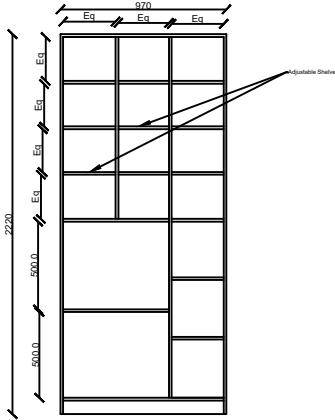

Approximately 970x2220x430mm deep Storage with open shelves

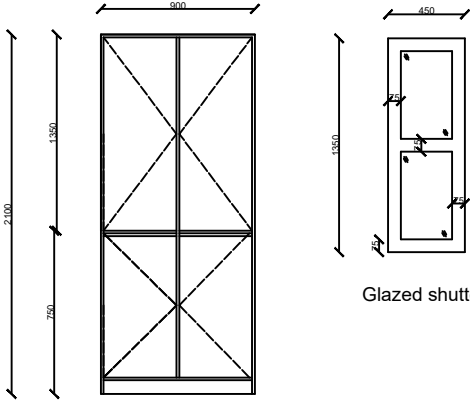

Front View

Glazed shutter detail

### Sketch 2.3

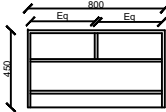

Approximately 800mmx450mmx400mm deep Storage with 2 nos of drawers at top

# Toilet Partition

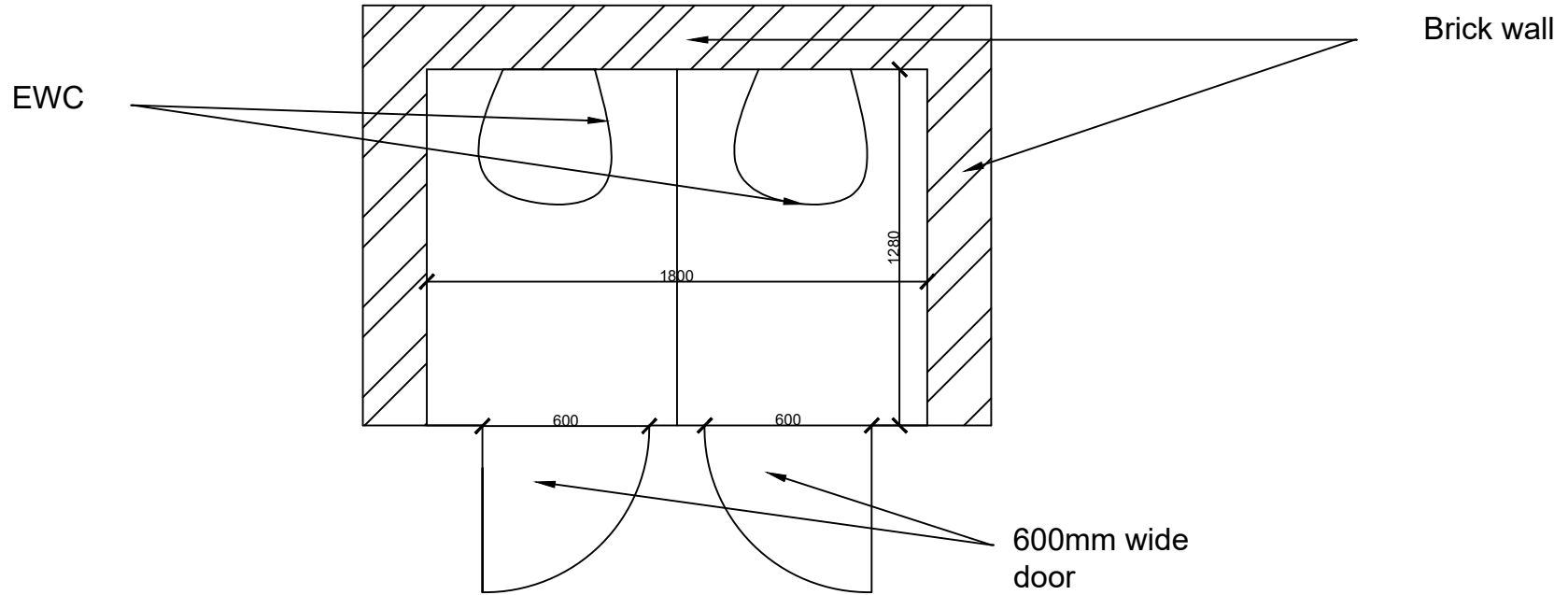

Plan