

Quantum Physics in one dimension

T. Giamarchi

http://dpmc.unige.ch/gr_giamarchi/



**UNIVERSITÉ
DE GENÈVE**

FNSNF

FONDS NATIONAL SUISSE
SCHWEIZERISCHER NATIONALFONDS
FONDO NAZIONALE SVIZZERO
SWISS NATIONAL SCIENCE FOUNDATION

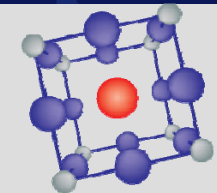

MaNEP
SWITZERLAND

A. Lobos (Geneva)

C. Kollath (Polytechnique)

M. Zvonarev (LPTMS)

P. Bouillot (Geneva)

C. Berthod (Geneva)



- Spin ladders:

A. Tsvelik (BNL), R. Chitra (Jussieu)

E. Orignac (ENS-Lyon), R. Citro (Salerno U.)

M. Klanjsek + group C. Berthier (Grenoble)

B. Thielemann + group C. Rugg (LCN/PSI) +LANL Group

D. Poilblanc , S Capponi (Toulouse), A. Läuchli (Dresden) , B. Normand

- Deconfinement:

A. Georges, S. Bierman (Polytechnique), A. Lichtenstein (Hamburg U.)

- Noise and bath:

M. Muller (ICTP), E. Demler (Harvard), E. Dalla Torre, E. Atman (Weizman)

- Ferromagnetic liquid:

V. Cheianov (Lancaster U.)

Questions

Questions

- Understood: free electrons

Questions

- Understood: free electrons
- Real systems : Coulomb interaction

Questions

- Understood: free electrons
- Real systems : Coulomb interaction
- Properties of realistic systems

Questions

- Understood: free electrons
- Real systems : Coulomb interaction
- Properties of realistic systems
- Free electron theory works quite well

Effect of interactions

Effect of interactions

- Landau Fermi liquid

Effect of interactions

- Landau Fermi liquid



Effect of interactions

- Landau Fermi liquid
- Individual fermionic excitations exist (quasiparticles)



Effect of interactions

- Landau Fermi liquid
- Individual fermionic excitations exist (quasiparticles)

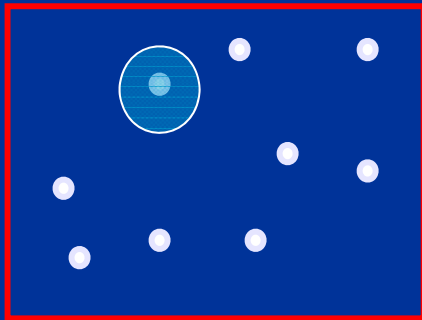

Effect of interactions

- Landau Fermi liquid
- Individual fermionic excitations exist (quasiparticles)

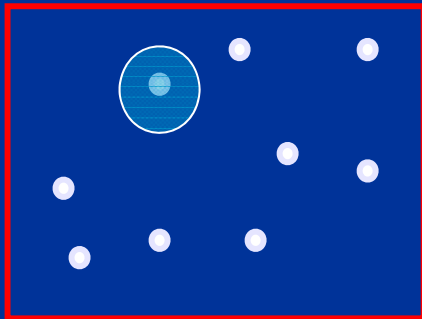

$$m \rightarrow m^*$$

Fermi liquid theory

Fermi liquid theory

- Shown perturbatively in U

Fermi liquid theory

- Shown perturbatively in U
- Much more general and robust

Fermi liquid theory

- Shown perturbatively in U
- Much more general and robust

Element	m^*/m	χ/χ_0
Nb	2	1
3He	6	20
Heavy fermion	100	100



• Transistor

• Transistor

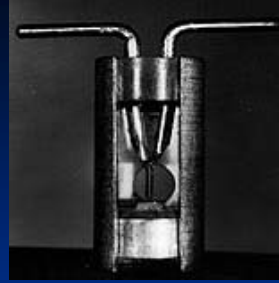

• Transistor

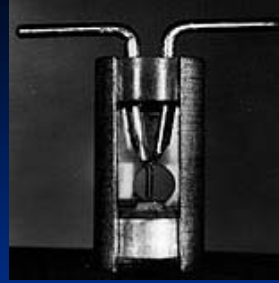

• Transistor

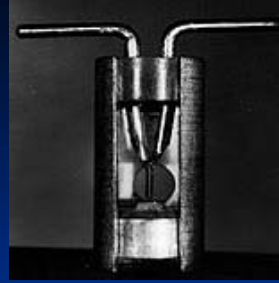

1956

• Transistor

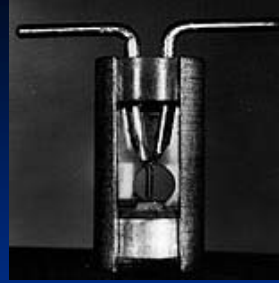

1956

• Supraconductivité

• Transistor

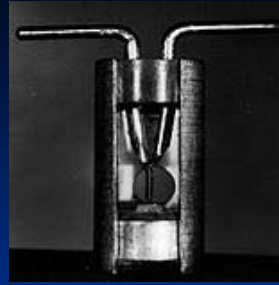

1956

• Supraconductivité



• Magnéto-résistance
géante

• Transistor

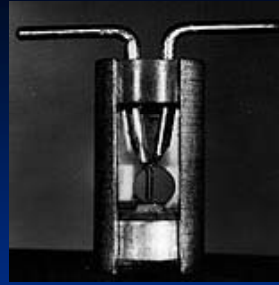

1956

• Supraconductivité



(1913), 1972,
1973, 1987, 2003

• Magnéto-résistance
géante

• Transistor

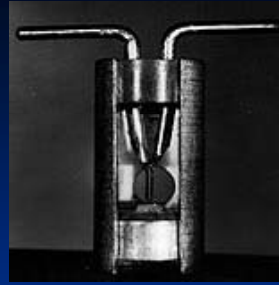

1956

• Supraconductivité



(1913), 1972,
1973, 1987, 2003

• Magnéto-résistance
géante

• Transistor

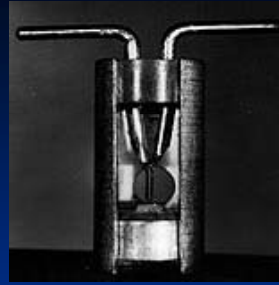

1956

• Supraconductivité



(1913), 1972,
1973, 1987, 2003

• Magnéto-résistance
géante

• Transistor

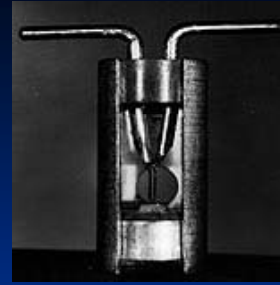

1956

• Supraconductivité



(1913), 1972,
1973, 1987, 2003

• Magnétorésistance
géante

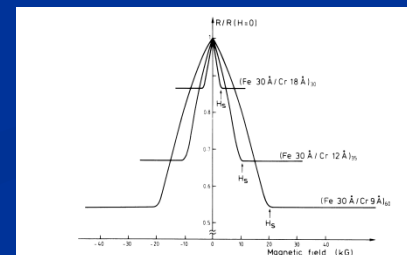

• Transistor

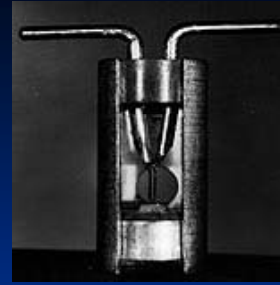

1956

• Supraconductivité



(1913), 1972,
1973, 1987, 2003

• Magnéto-résistance
géante

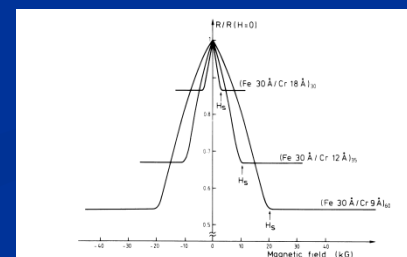

• Transistor

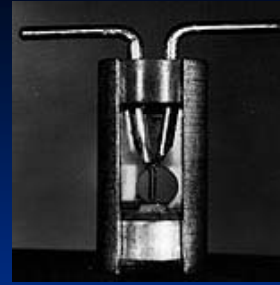

1956

• Supraconductivité



(1913), 1972,
1973, 1987, 2003

• Magnétorésistance
géante

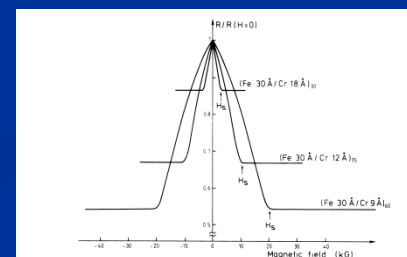

2007

• Transistor

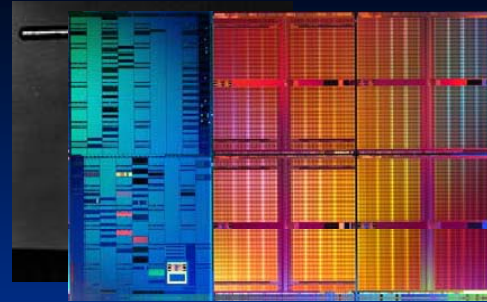

1956

• Supraconductivité



(1913), 1972,
1973, 1987, 2003

• Magnétorésistance
géante



2007

• Transistor

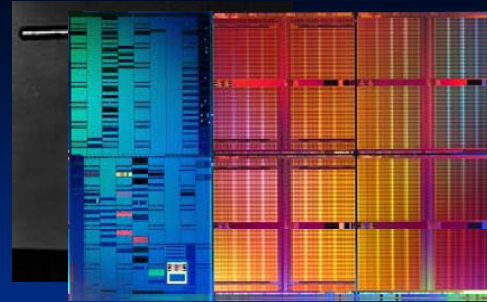

1956

• Supraconductivité



(1913), 1972,
1973, 1987, 2003

• Magnétorésistance
géante



2007

• Transistor

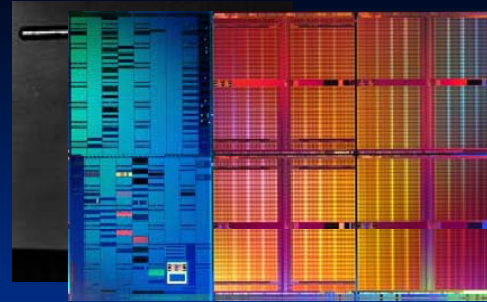

1956

• Supraconductivité



(1913), 1972,
1973, 1987, 2003

• Magnétorésistance
géante



2007

One dimension is different

One dimension is different

- No individual excitation can exist (only collective ones)

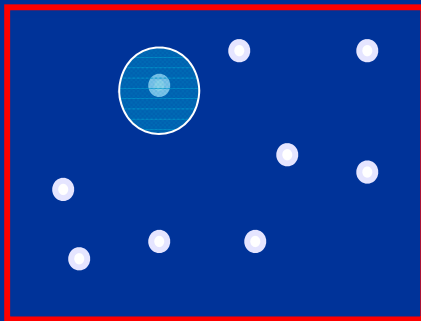

One dimension is different

- No individual excitation can exist (only collective ones)

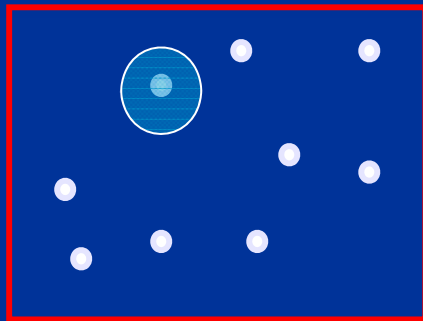

One dimension is different

- No individual excitation can exist (only collective ones)

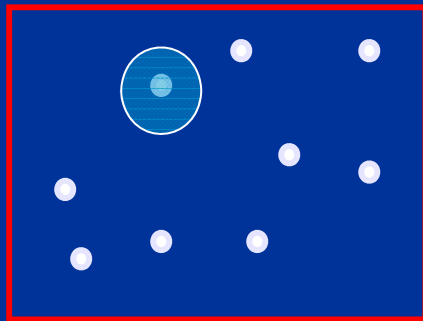

One dimension is different

- No individual excitation can exist (only collective ones)

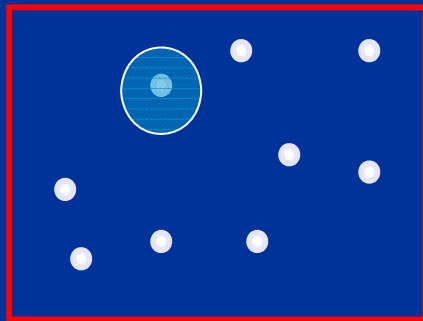

- Strong quantum fluctuations

One dimension is different

- No individual excitation can exist (only collective ones)

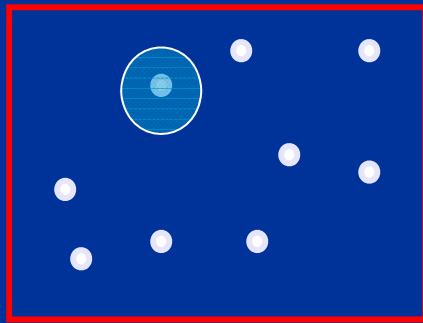

- Strong quantum fluctuations

$$\psi \rightarrow \psi e^{i\theta}$$

One dimension is different

- No individual excitation can exist (only collective ones)

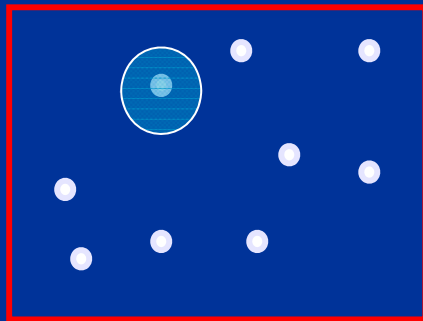

- Strong quantum fluctuations

$$\psi \rightarrow \psi e^{i\theta}$$

Continuous symmetry

One dimension is different

- No individual excitation can exist (only collective ones)

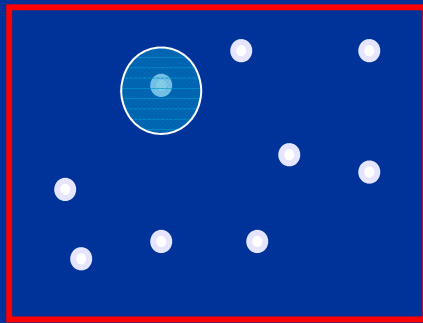

- Strong quantum fluctuations

$$\psi \rightarrow \psi e^{i\theta}$$

Continuous symmetry

An exciting theoretical problem

How to make a theory

How to make a theory



How to make a theory



Tomonaga



How to make a theory



Tomonaga

Luttinger

60': A. Larkin, I. Dzialoshinskii, L. Gorkov, Bichkov

E. Lieb, D. Mathis

70': A. Luther, V.J. Emery

80': F.D.M. Haldane

How to make a theory



Tomonaga

Luttinger

60': A. Larkin, I. Dzialoshinskii, L. Gorkov, Bichkov

E. Lieb, D. Mathis

70': A. Luther, V.J. Emery

80': F.D.M. Haldane

How to make a theory



Tomonaga

Luttinger

60': A. Larkin, I. Dzialoshinskii, L. Gorkov, Bichkov

E. Lieb, D. Mathis

70': A. Luther, V.J. Emery

80': F.D.M. Haldane

How to make a theory

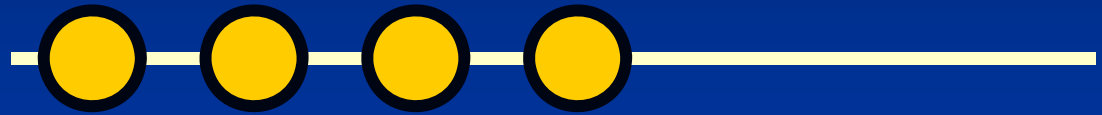

Tomonaga

Luttinger

60': A. Larkin, I. Dzialoshinskii, L. Gorkov, Bichkov

E. Lieb, D. Mathis

70': A. Luther, V.J. Emery

80': F.D.M. Haldane

How to make a theory

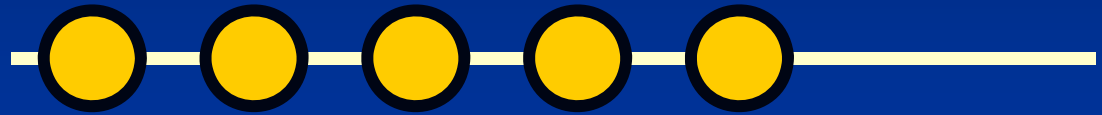

Tomonaga

Luttinger

60': A. Larkin, I. Dzialoshinskii, L. Gorkov, Bichkov

E. Lieb, D. Mathis

70': A. Luther, V.J. Emery

80': F.D.M. Haldane

How to make a theory

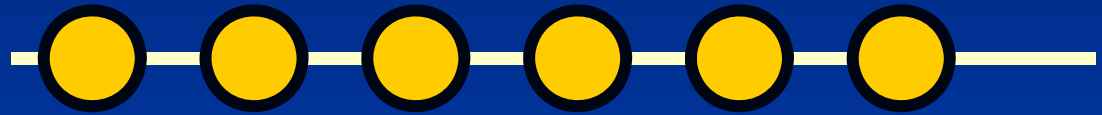

Tomonaga

Luttinger

60': A. Larkin, I. Dzialoshinskii, L. Gorkov, Bichkov

E. Lieb, D. Mathis

70': A. Luther, V.J. Emery

80': F.D.M. Haldane

How to make a theory

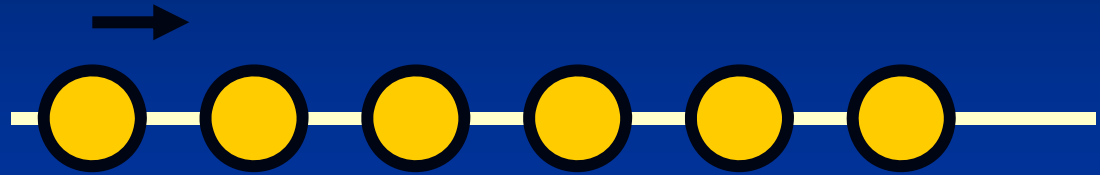

Tomonaga

Luttinger

60': A. Larkin, I. Dzialoshinskii, L. Gorkov, Bichkov

E. Lieb, D. Mathis

70': A. Luther, V.J. Emery

80': F.D.M. Haldane

How to make a theory

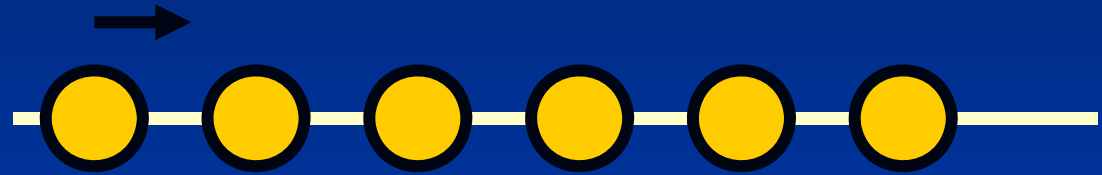

Tomonaga

Luttinger

60': A. Larkin, I. Dzialoshinskii, L. Gorkov, Bichkov

E. Lieb, D. Mathis

70': A. Luther, V.J. Emery

80': F.D.M. Haldane

How to make a theory

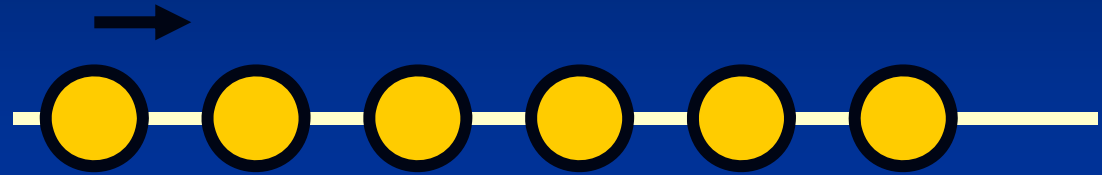

Tomonaga

Luttinger

Good excitations: collective ones

60': A. Larkin, I. Dzialoshinskii, L. Gorkov, Bichkov

E. Lieb, D. Mathis

70': A. Luther, V.J. Emery

80': F.D.M. Haldane

How to make a theory

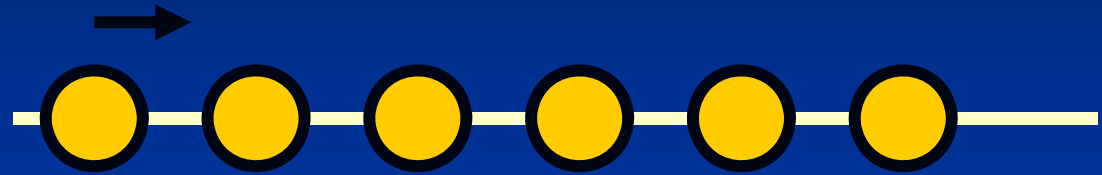

Tomonaga

Luttinger

Good excitations: collective ones

60': A. Larkin, I. Dzialoshinskii, L. Gorkov, Bichkov

E. Lieb, D. Mathis

70': A. Luther, V.J. Emery

80': F.D.M. Haldane

How to make a theory



Tomonaga



Luttinger

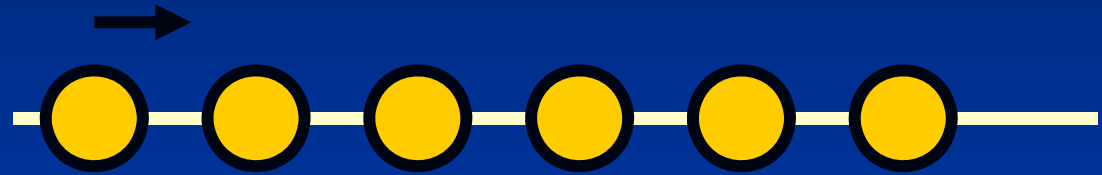

Good excitations: collective ones

60': A. Larkin, I. Dzialoshinskii, L. Gorkov, Bichkov

E. Lieb, D. Mathis

70': A. Luther, V.J. Emery

80': F.D.M. Haldane



How to make a theory

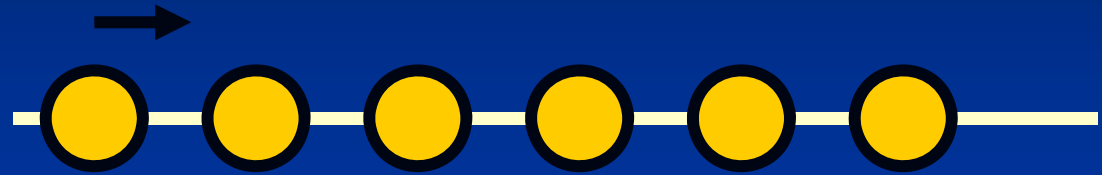

Tomonaga

Luttinger

Good excitations: collective ones

60': A. Larkin, I. Dzialoshinskii, L. Gorkov, Bichkov

E. Lieb, D. Mathis

70': A. Luther, V.J. Emery

80': F.D.M. Haldane

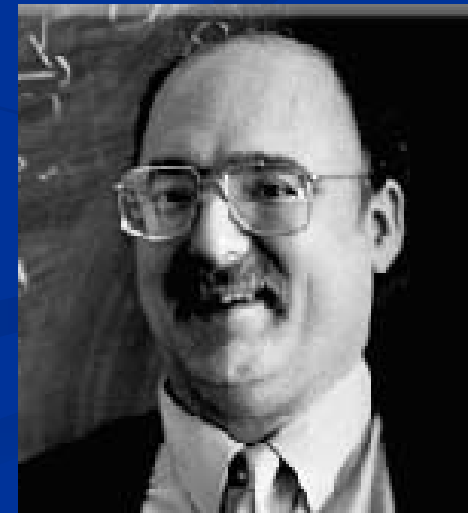

How to make a theory

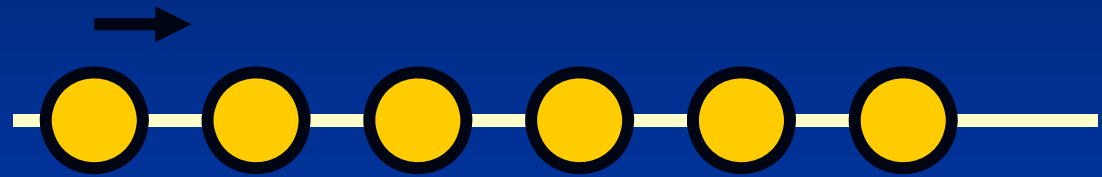

Tomonaga

Luttinger

Good excitations: collective ones

60': A. Larkin, I. Dzialoshinskii, L. Gorkov, Bichkov

E. Lieb, D. Mathis

70': A. Luther, V.J. Emery

80': F.D.M. Haldane

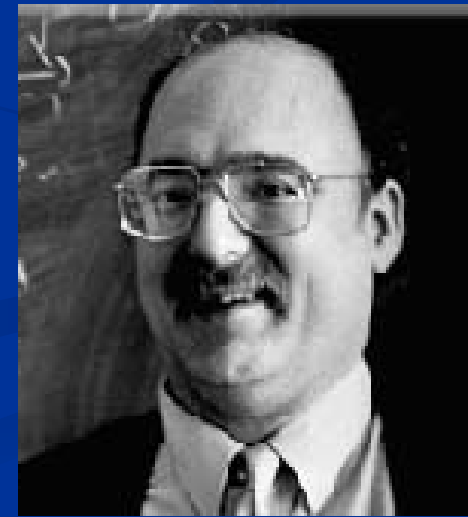

How to make a theory



Tomonaga



Luttinger

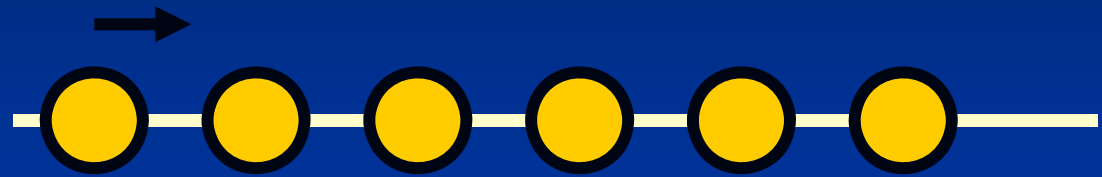

Good excitations: collective ones

60': A. Larkin, I. Dzialoshinskii, L. Gorkov, Bichkov

E. Lieb, D. Mathis

70': A. Luther, V.J. Emery

80': F.D.M. Haldane

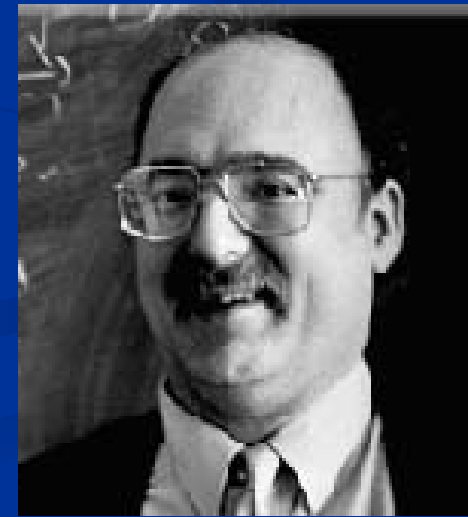

How to make a theory

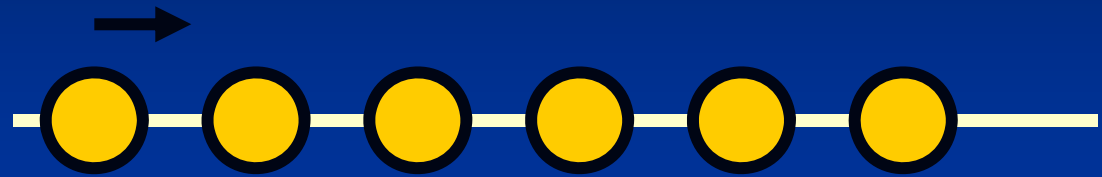

Tomonaga

Luttinger

Good excitations: collective ones

60': A. Larkin, I. Dzialoshinskii, L. Gorkov, Bichkov

E. Lieb, D. Mathis

70': A. Luther, V.J. Emery

80': F.D.M. Haldane

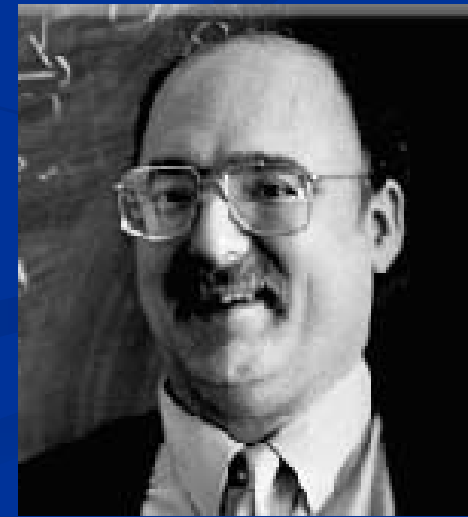

How to make a theory

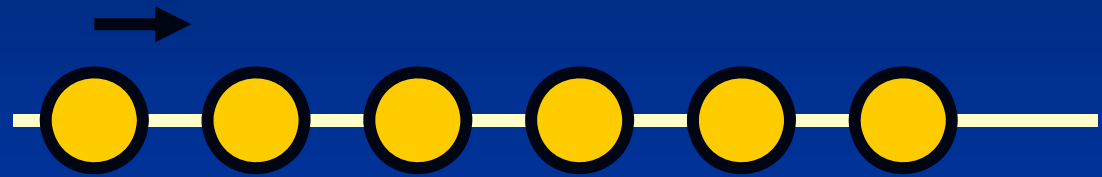

Tomonaga

Luttinger

Good excitations: collective ones

60': A. Larkin, I. Dzialoshinskii, L. Gorkov, Bichkov

E. Lieb, D. Mathis

70': A. Luther, V.J. Emery

80': F.D.M. Haldane

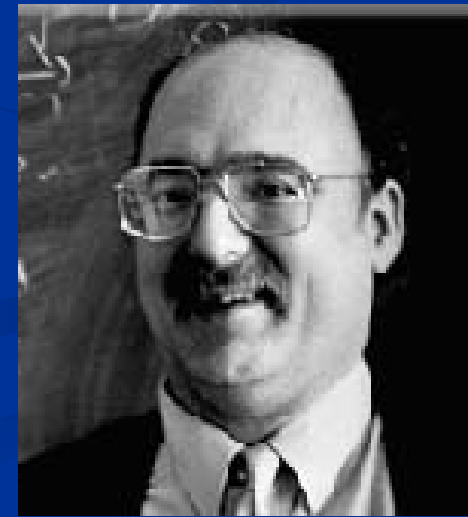

Universal description: Luttinger liquid

Universal description: Luttinger liquid

- Low energy effective description

Universal description: Luttinger liquid

- Low energy effective description
- *All* effects described by *two* parameters:
u and K (Luttinger liquid parameters)

Universal description: Luttinger liquid

- Low energy effective description
- **All** effects described by **two** parameters:
u and K (Luttinger liquid parameters)
- Power law correlation functions

Power-law correlations

$$\langle \psi(r)\psi^\dagger(0) \rangle = A_1 \left(\frac{\alpha}{r} \right)^{\frac{1}{2K}} + \dots$$

$$\langle \rho(r)\rho(0) \rangle = \rho_0^2 + \frac{K}{2\pi^2} \frac{y_\alpha^2 - x^2}{(y_\alpha^2 + x^2)^2} + A_3 \cos(2\pi\rho_0 x) \left(\frac{1}{r} \right)^{2K} + \dots$$

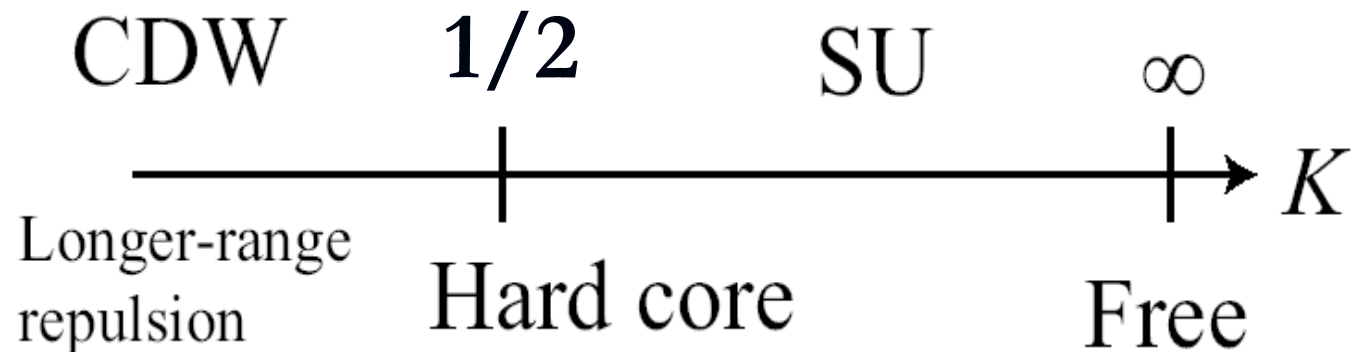

Power-law correlations

$$\langle \psi(r) \psi^\dagger(0) \rangle = A_1 \left(\frac{\alpha}{r} \right)^{\frac{1}{2K}} + \dots$$

$$\langle \rho(r) \rho(0) \rangle = \rho_0^2 + \frac{K}{2\pi^2} \frac{y_\alpha^2 - x^2}{(y_\alpha^2 + x^2)^2} + A_3 \cos(2\pi \rho_0 x) \left(\frac{1}{r} \right)^{2K} + \dots$$

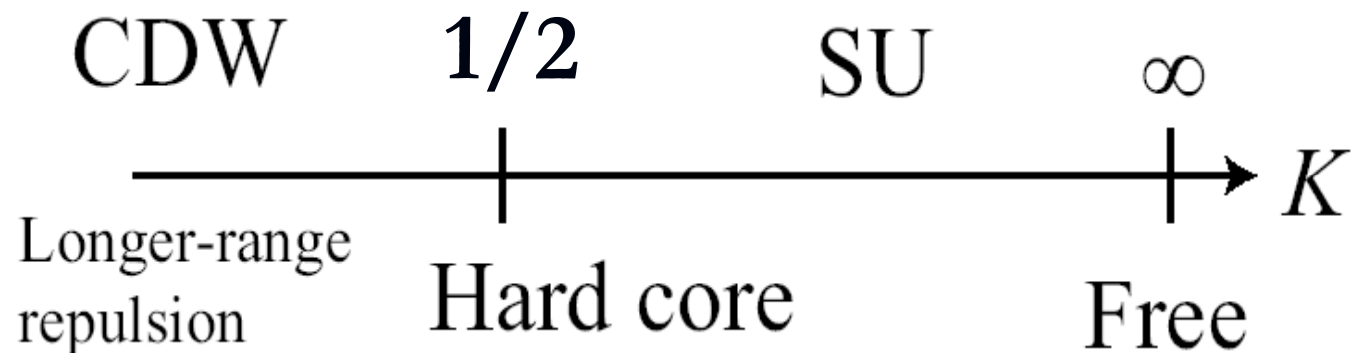

Power-law correlations

$$\langle \psi(r) \psi^\dagger(0) \rangle = A_1 \left(\frac{\alpha}{r} \right)^{\frac{1}{2K}} + \dots$$

$$\langle \rho(r) \rho(0) \rangle = \rho_0^2 + \frac{K}{2\pi^2} \frac{y_\alpha^2 - x^2}{(y_\alpha^2 + x^2)^2} + A_3 \cos(2\pi \rho_0 x) \left(\frac{1}{r} \right)^{2K} + \dots$$

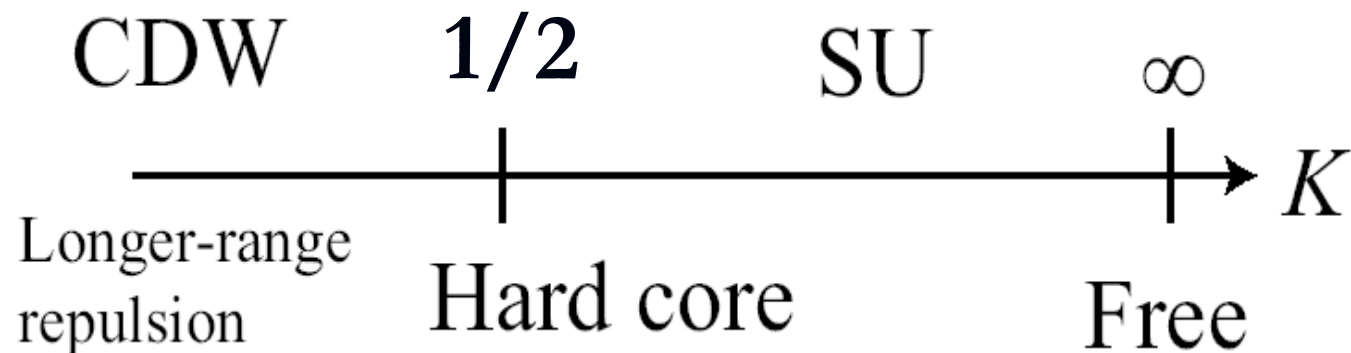

Luttinger parameters

**General Relation of Correlation Exponents and Spectral Properties of
One-Dimensional Fermi Systems: Application to the Anisotropic**

$S = \frac{1}{2}$ Heisenberg Chain

F. D. M. Haldane

Haldane, F. D. M. (1980). *Phys. Rev. Lett.*, **45**, 1358.

Luttinger parameters

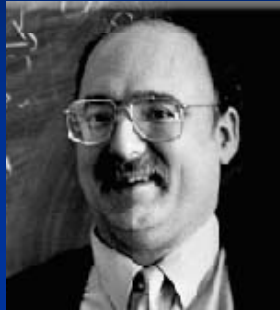

General Relation of Correlation Exponents and Spectral Properties of One-Dimensional Fermi Systems: Application to the Anisotropic

$S = \frac{1}{2}$ Heisenberg Chain

F. D. M. Haldane

Haldane, F. D. M. (1980). *Phys. Rev. Lett.*, **45**, 1358.

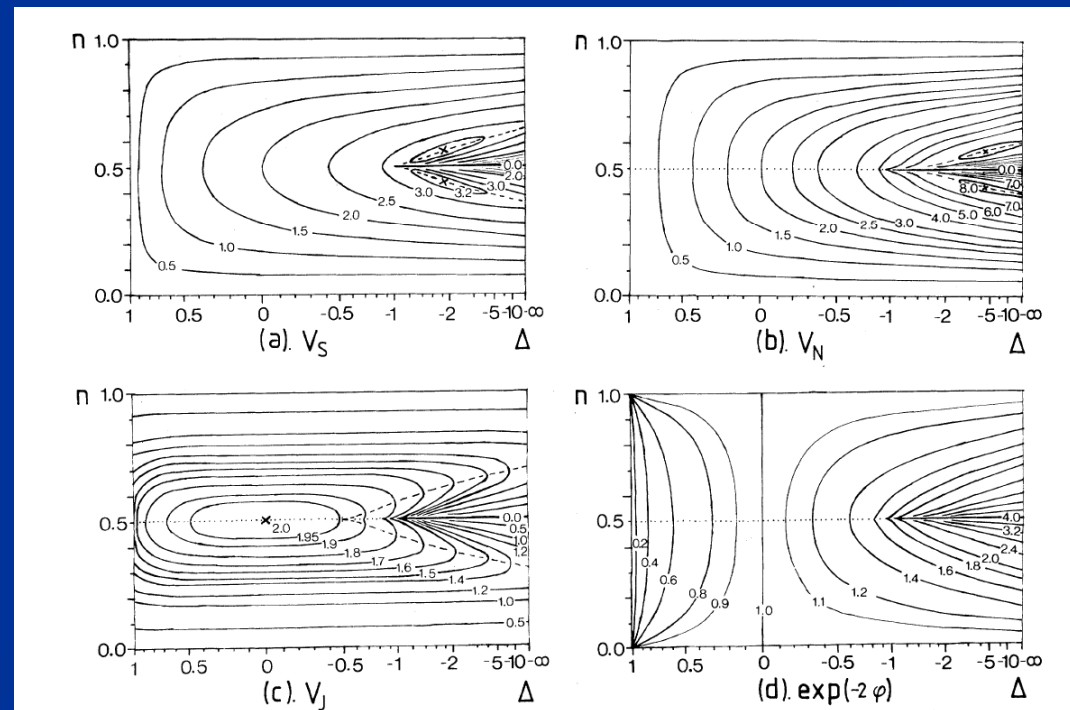

Luttinger parameters

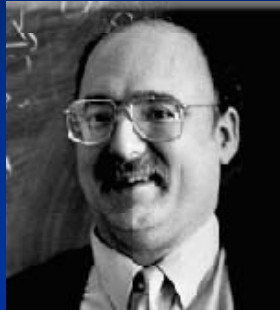

General Relation of Correlation Exponents and Spectral Properties of One-Dimensional Fermi Systems: Application to the Anisotropic

$S = \frac{1}{2}$ Heisenberg Chain

F. D. M. Haldane

Haldane, F. D. M. (1980). *Phys. Rev. Lett.*, **45**, 1358.

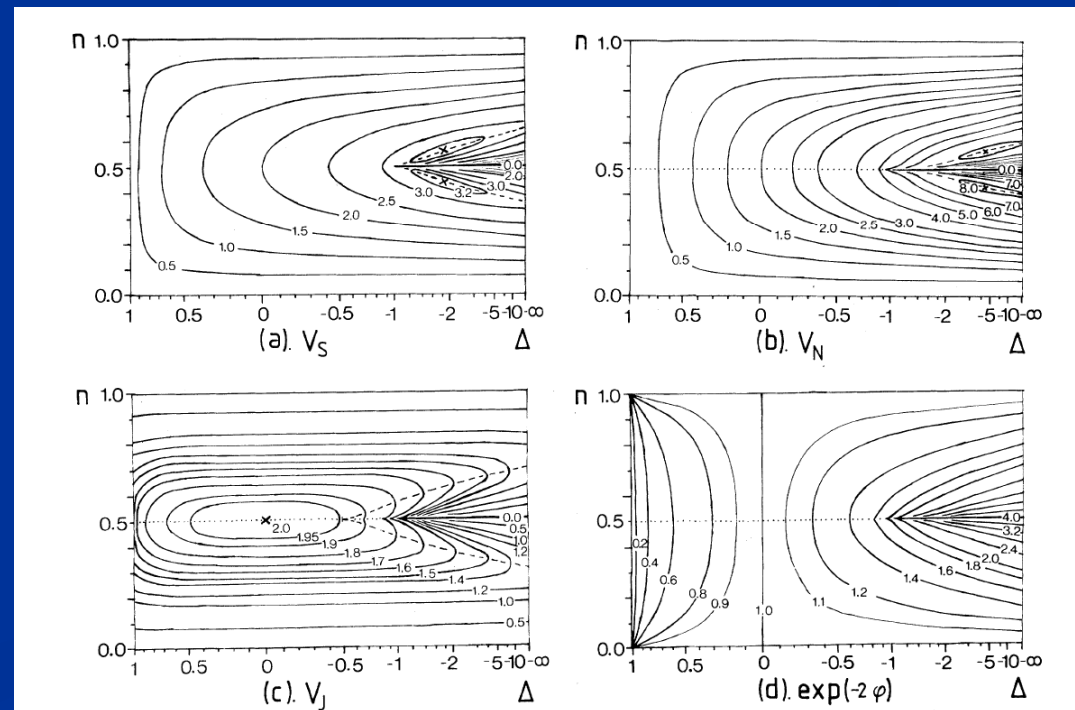

Luttinger parameters

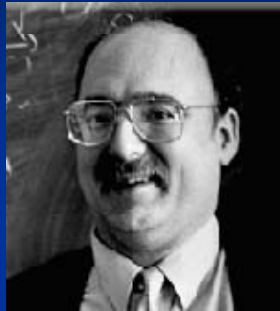

General Relation of Correlation Exponents and Spectral Properties of One-Dimensional Fermi Systems: Application to the Anisotropic $S = \frac{1}{2}$ Heisenberg Chain

F. D. M. Haldane

Haldane, F. D. M. (1980). *Phys. Rev. Lett.*, **45**, 1358.

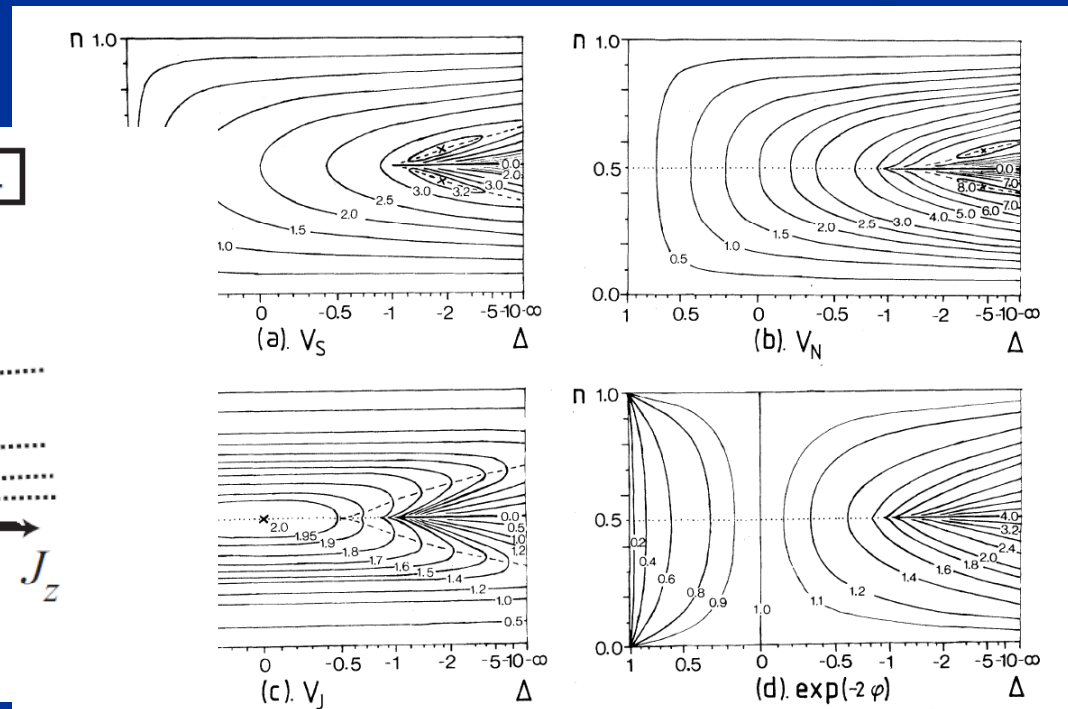
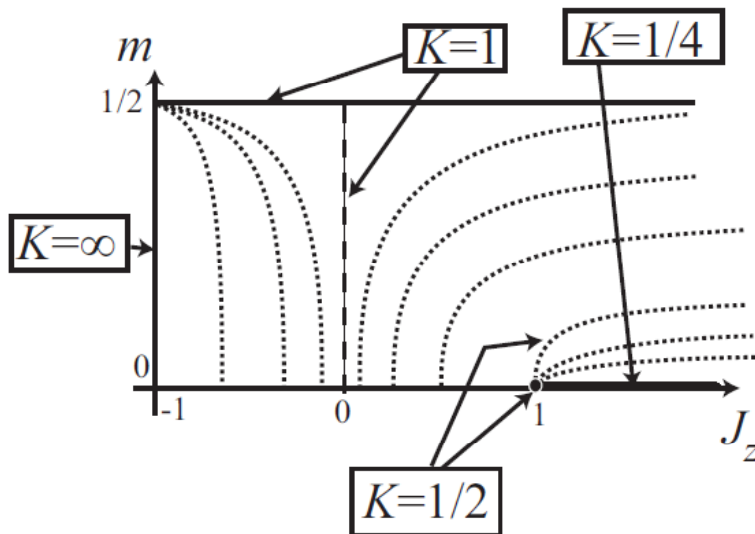

Correlation Exponents and the Metal-Insulator Transition in the One-Dimensional Hubbard Model

H. J. Schulz

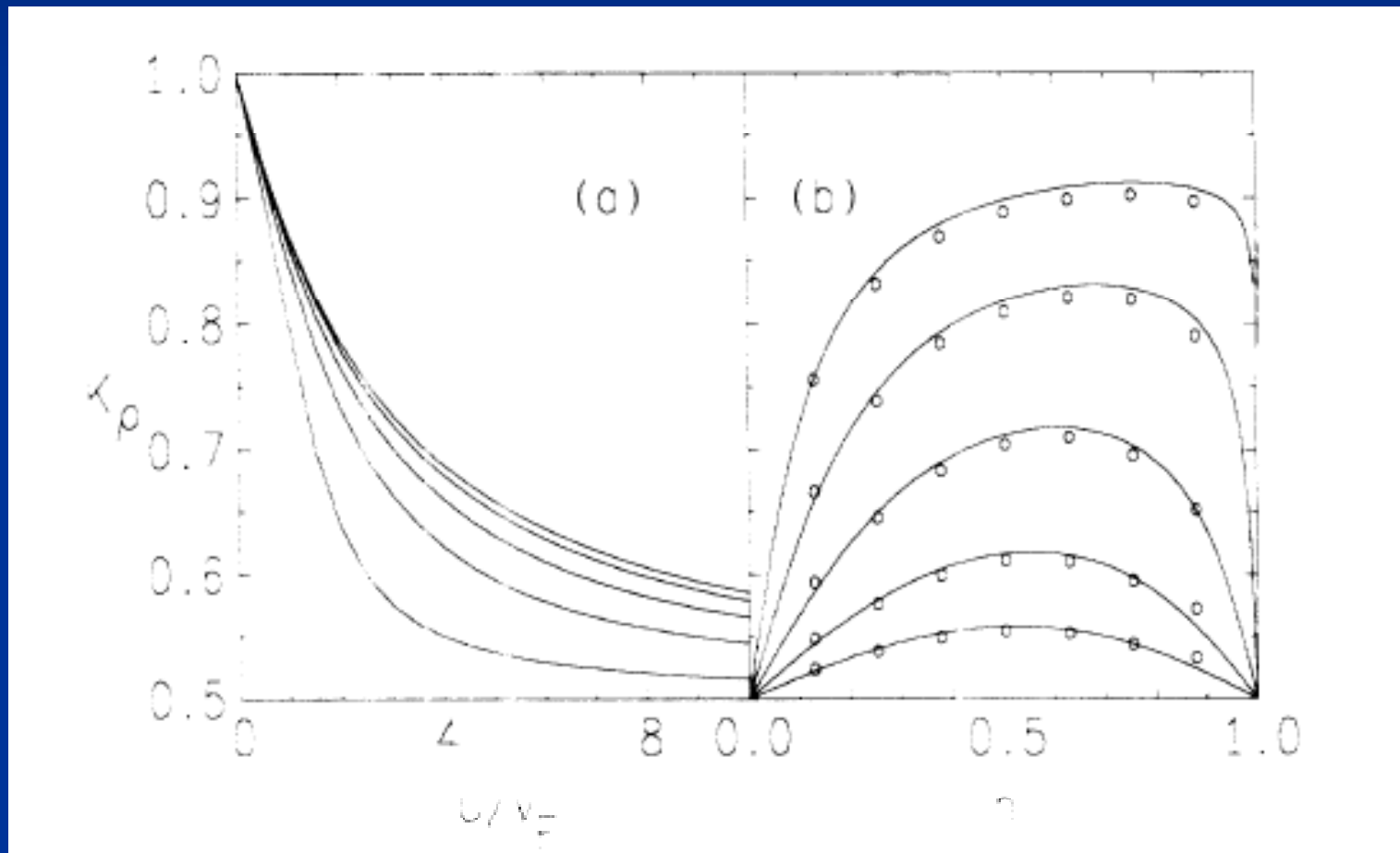



Correlation Exponents and the Metal-Insulator Transition in the One-Dimensional Hubbard Model

H. J. Schulz

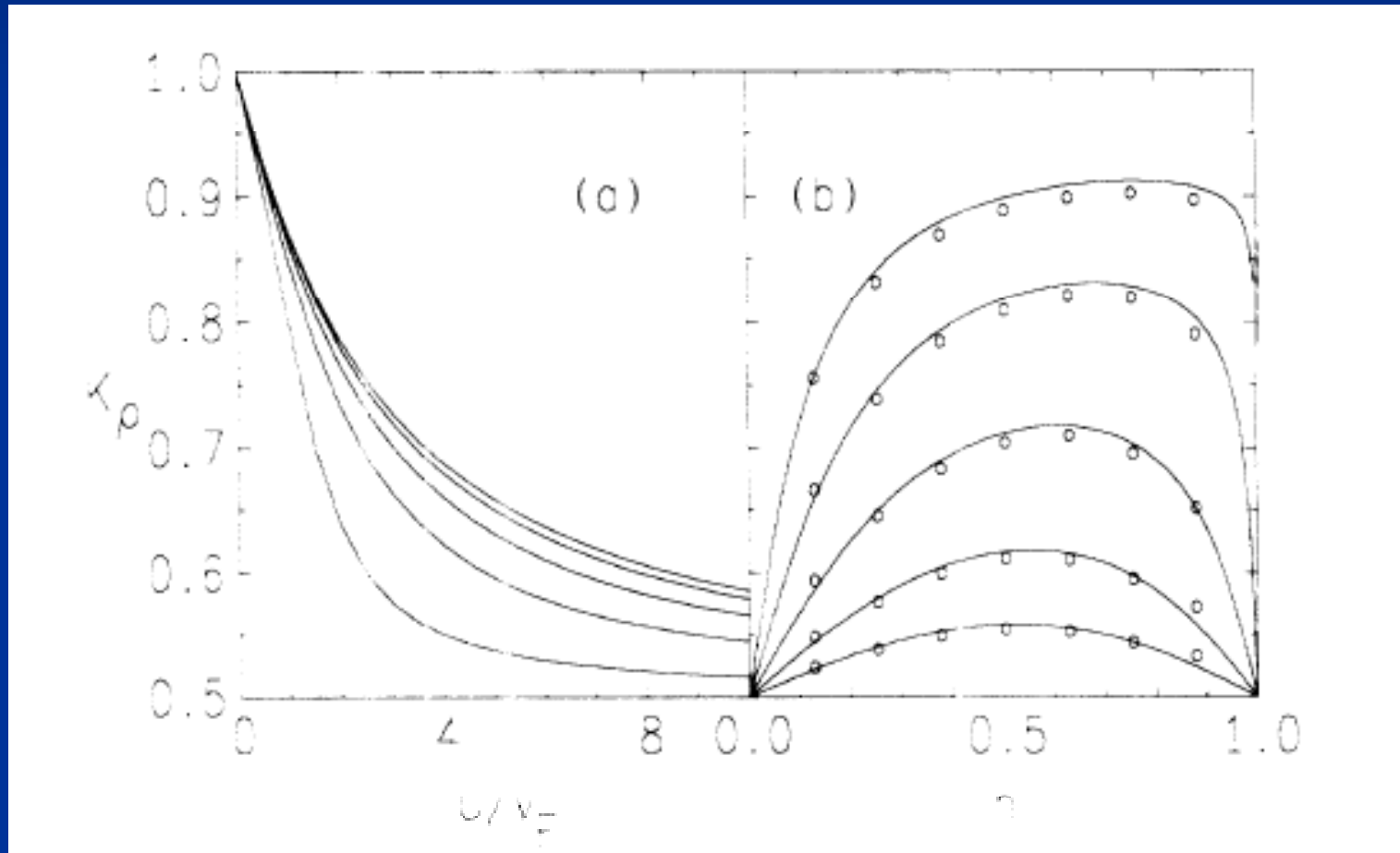

Fractional excitations

Spin

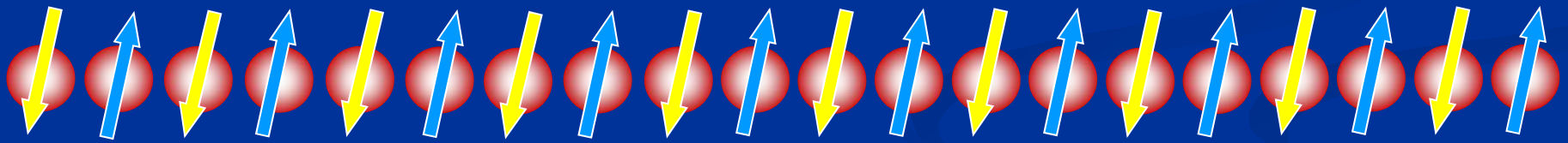

Fractional excitations

Spin

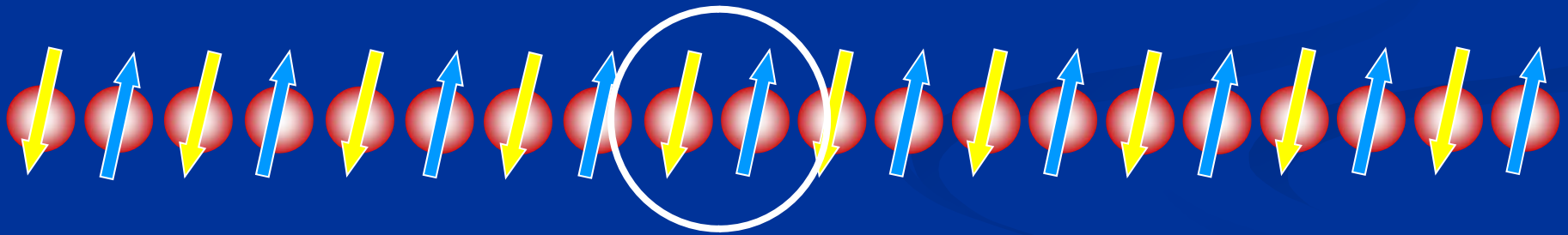

Fractional excitations

Spin

Charge

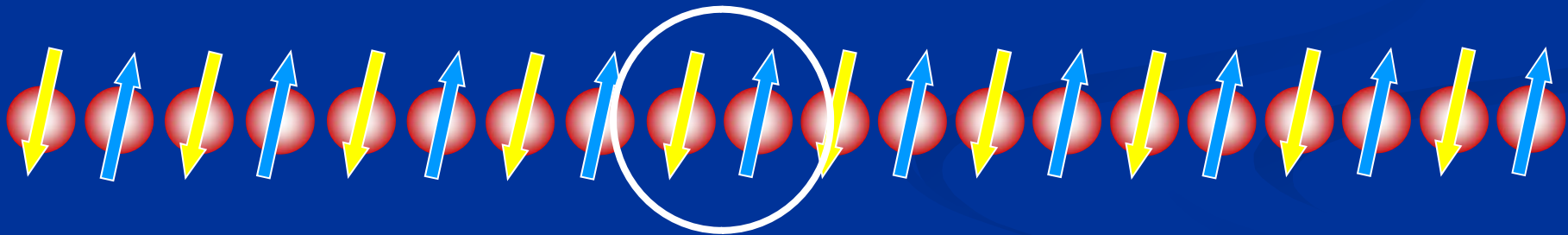

Spinon

Fractional excitations

Spin

Charge

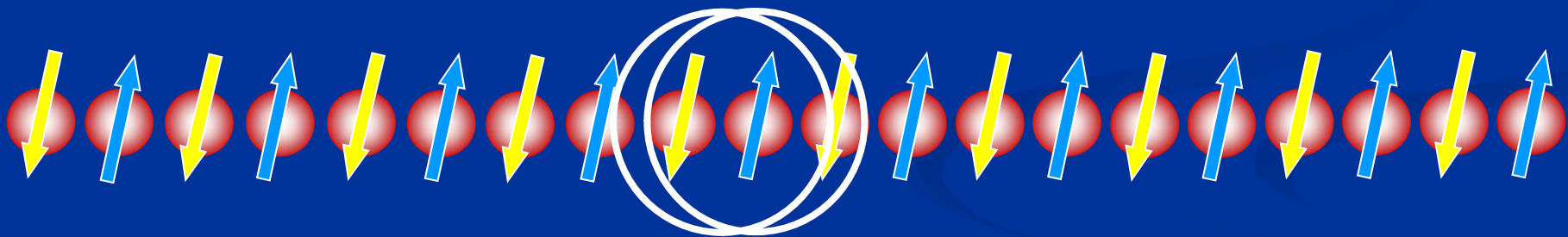

Spinon

Fractional excitations

Spin

Charge

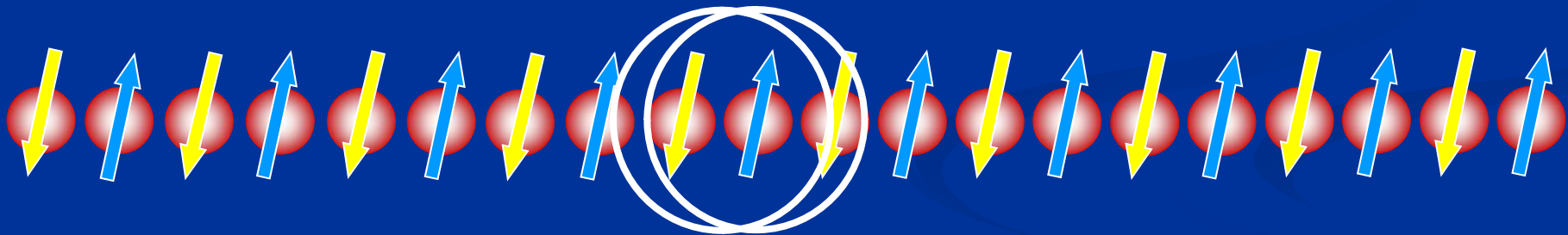

Spinon

Fractional excitations

Spin

Charge

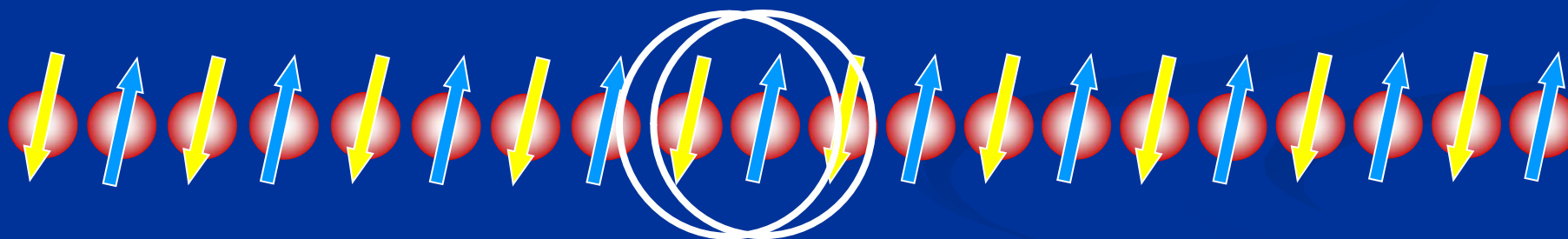

Spinon

Holon

Does Luttinger Liquid exists ?

Spin chains

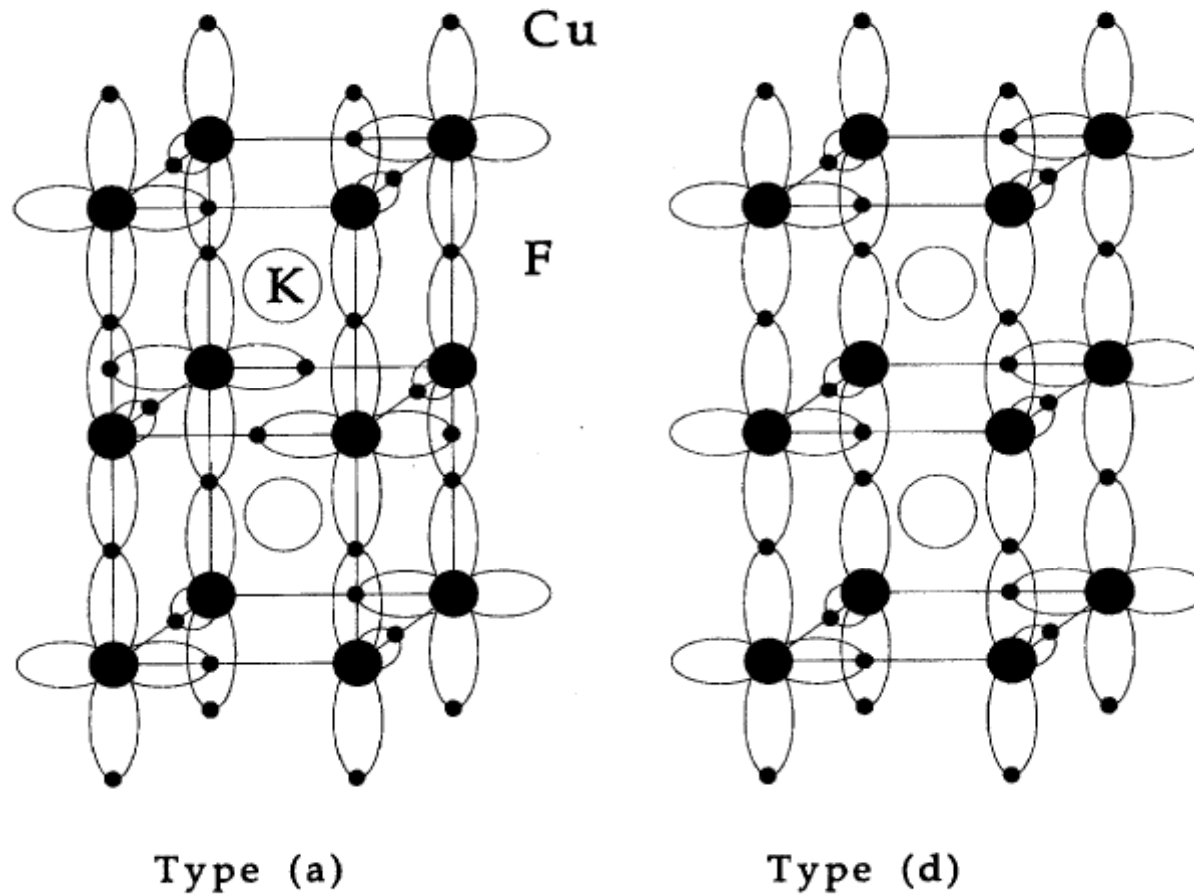

Hint in spin systems

Hint in spin systems

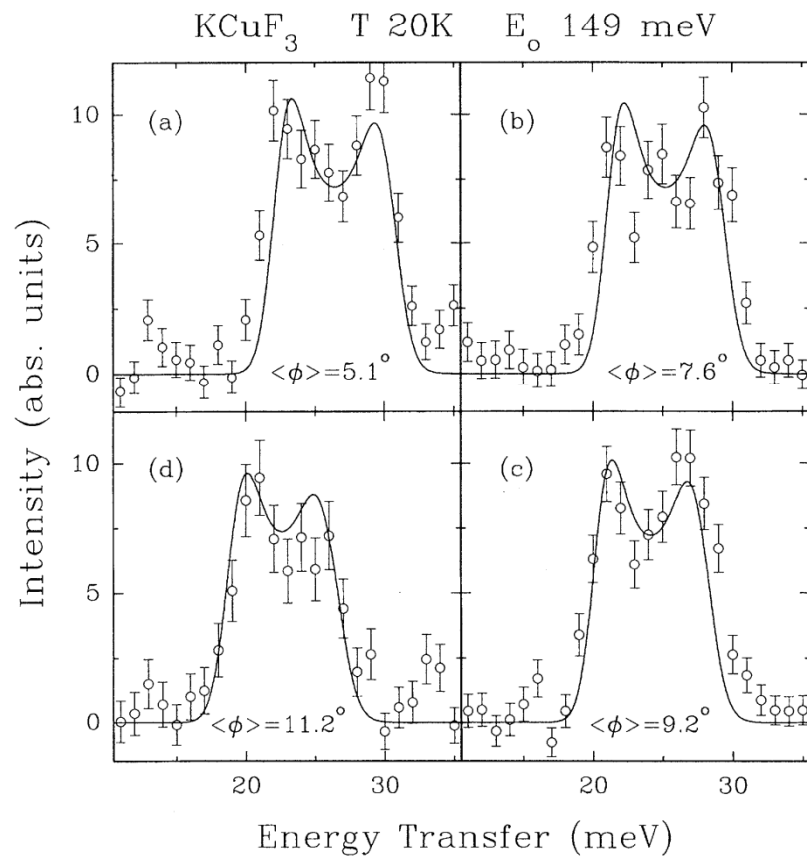

Hint in spin systems

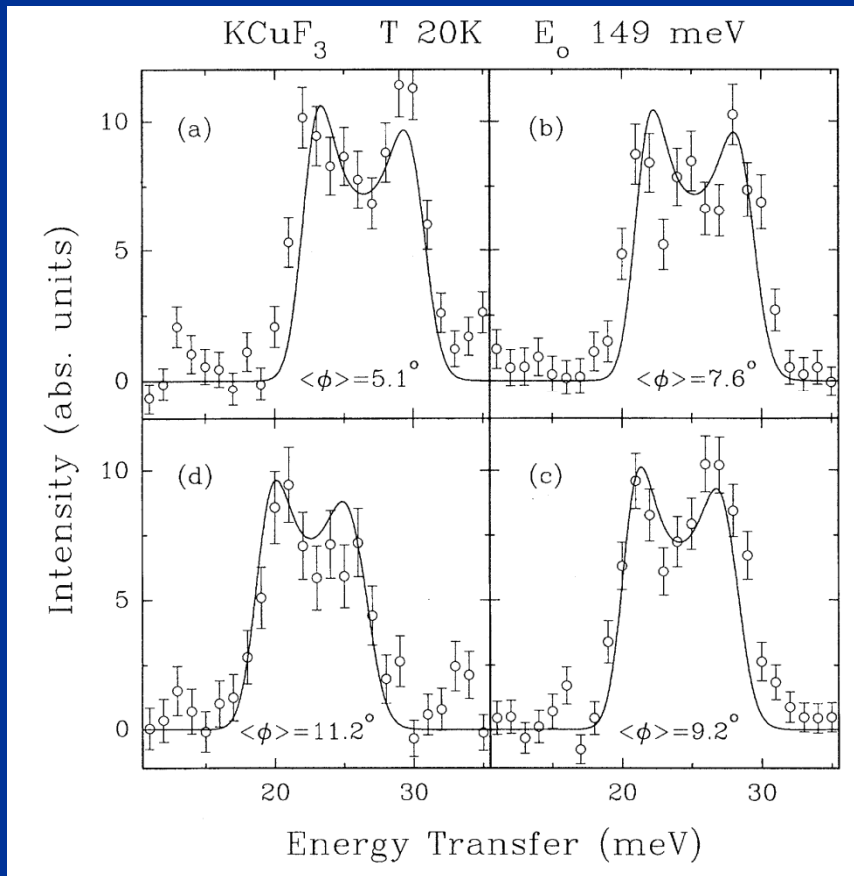

Tennent et al. PRB 52 13368 (1995)

Hint in spin systems

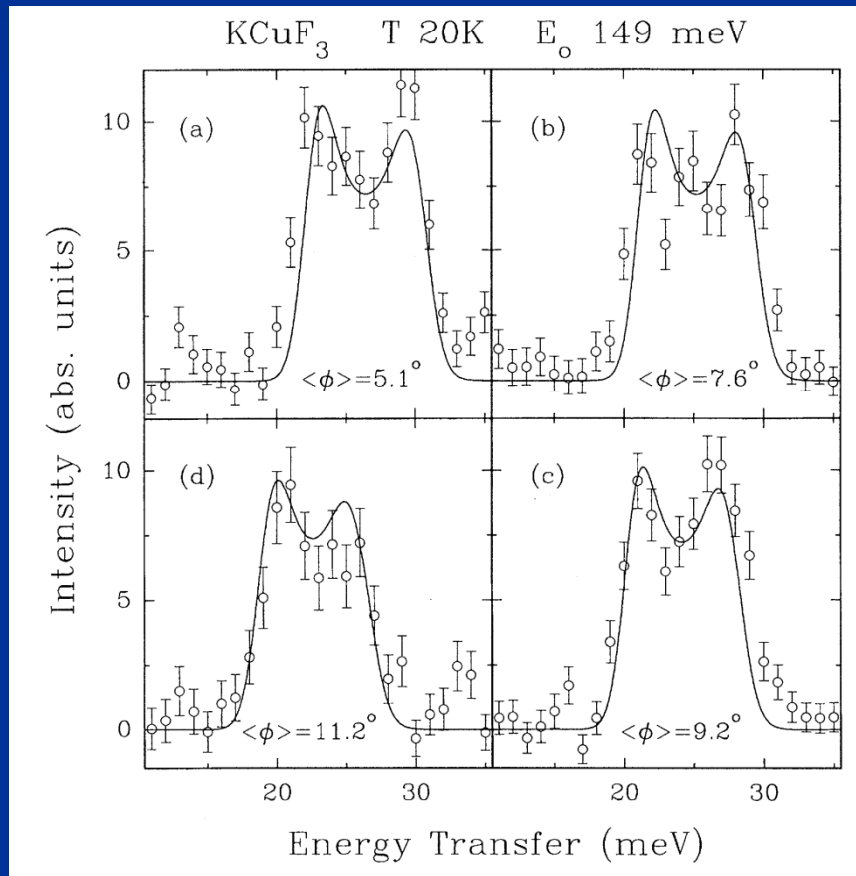

H. J. Schulz PRB 34 6372 (1986)

Tennent et al. PRB 52 13368 (1995)

Hint in spin systems

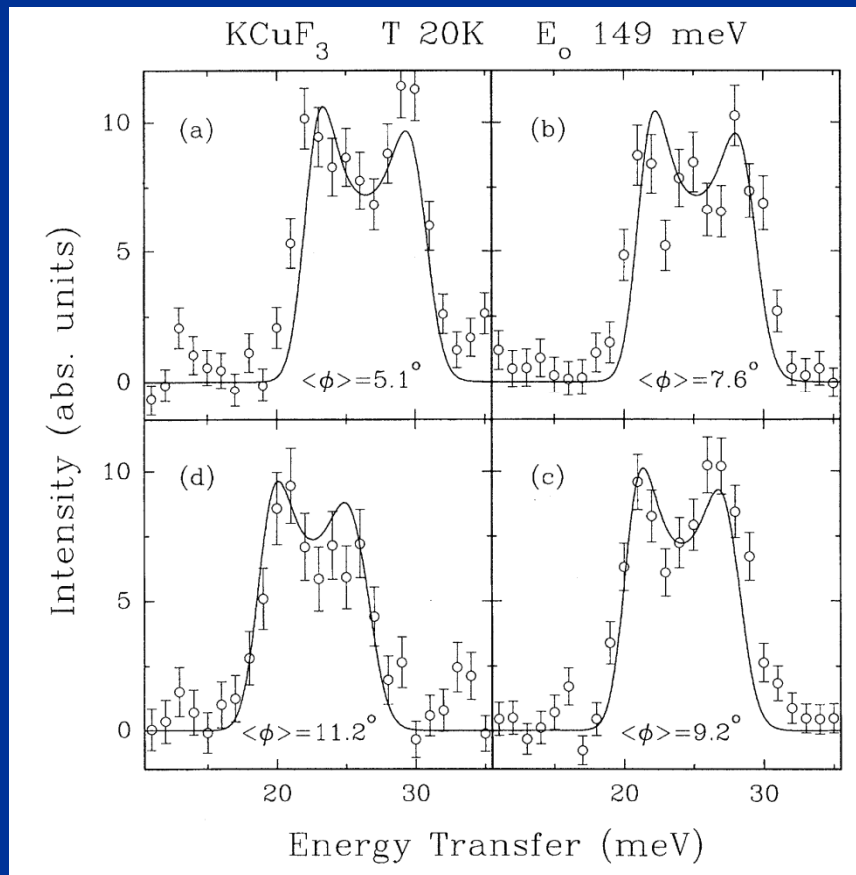

H. J. Schulz PRB 34 6372 (1986)

Lineshape:

FT of power law better

than two

gaussian/Lorentzian peaks

Tennent et al. PRB 52 13368 (1995)

Organic conductors

1973: F.Wudl, D.Cowan, A.Garito, A.Heeger

Organic conductors

1973: F.Wudl, D.Cowan, A.Garito, A.Heeger

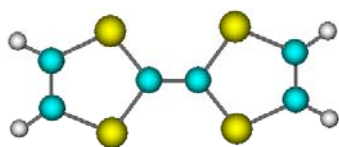

+

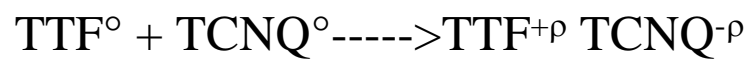
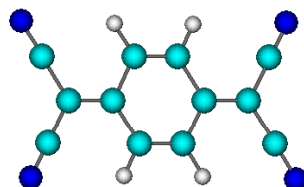

Organic conductors

1973: F.Wudl, D.Cowan, A.Garito, A.Heeger

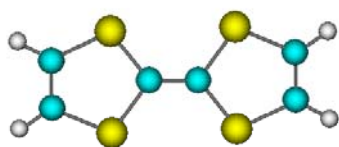

+

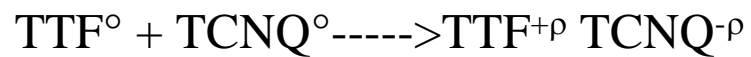
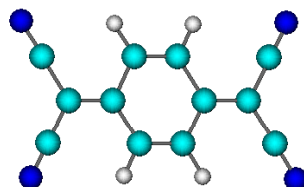

Organic conductors

1973: F.Wudl, D.Cowan, A.Garito, A.Heeger

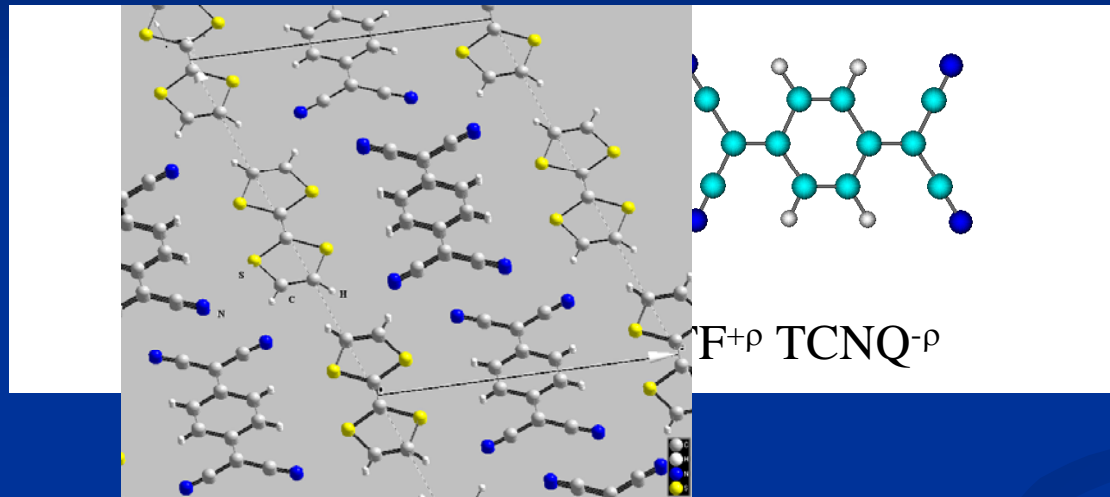

Organic conductors

1973: F.Wudl, D.Cowan, A.Garito, A.Heeger

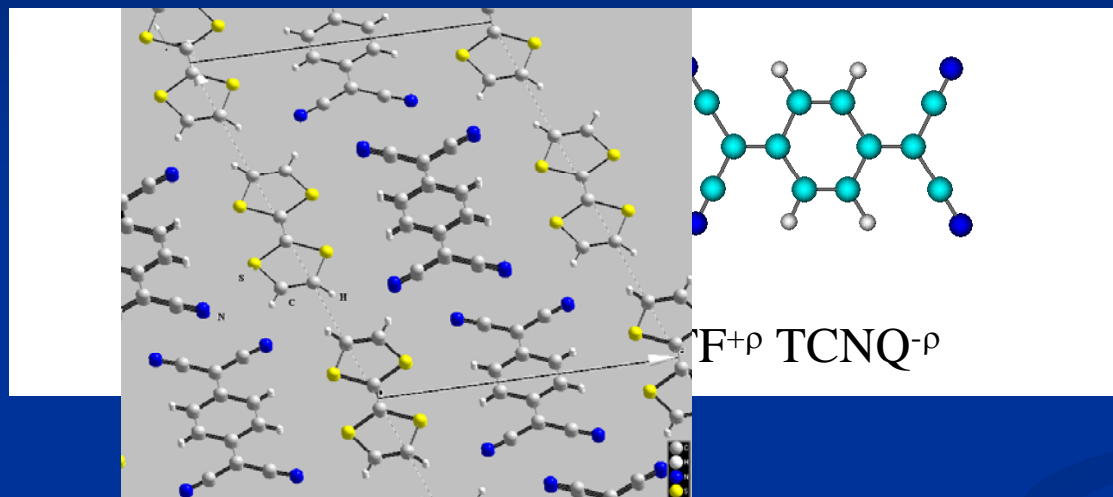

1979: K. Bechgaard

Organic conductors

1973: F.Wudl, D.Cowan, A.Garito, A.Heeger

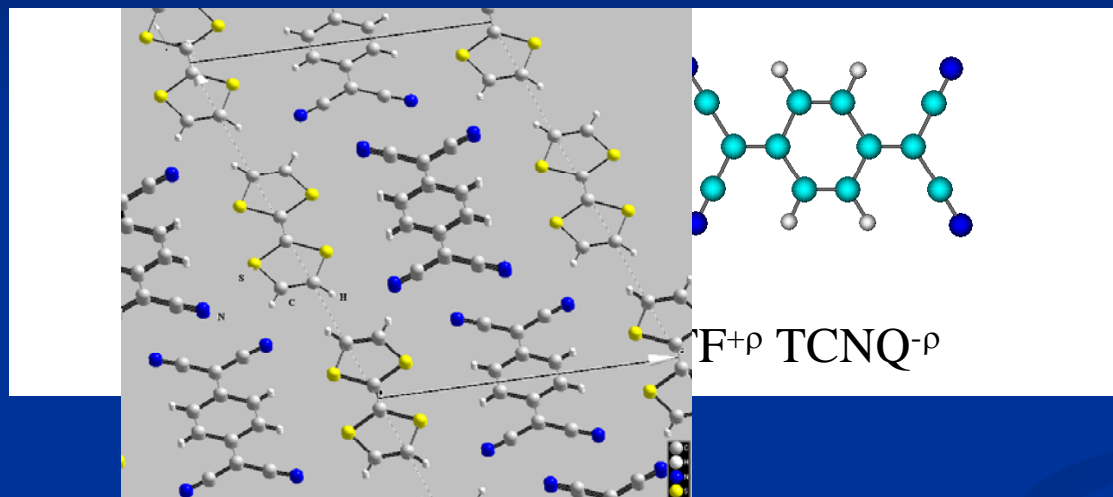

1979: K. Bechgaard

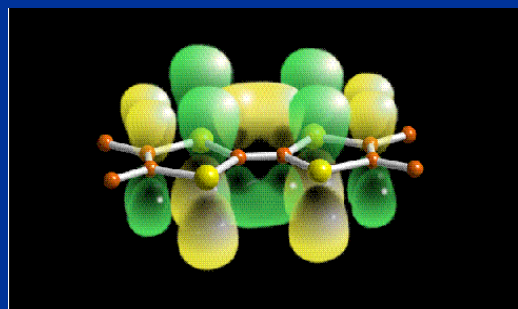

Organic conductors

1973: F.Wudl, D.Cowan, A.Garito, A.Heeger

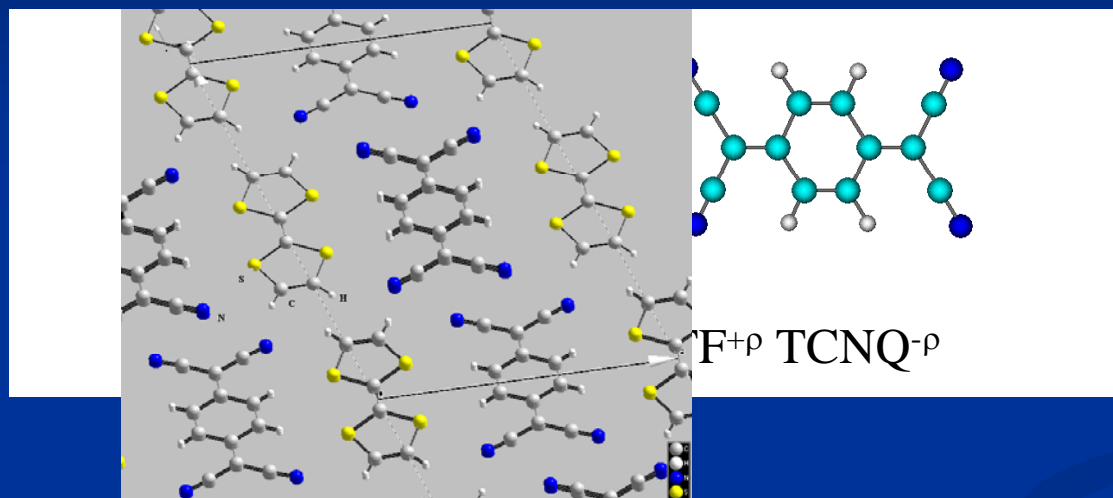

1979: K. Bechgaard

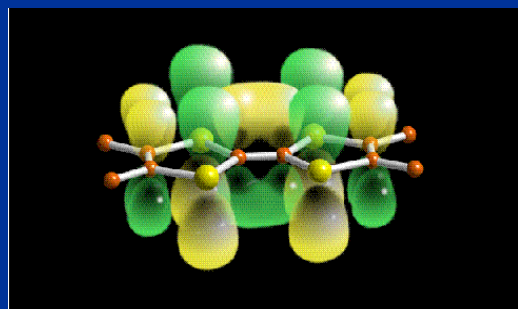

TMTSF

Organic conductors

1973: F.Wudl, D.Cowan, A.Garito, A.Heeger

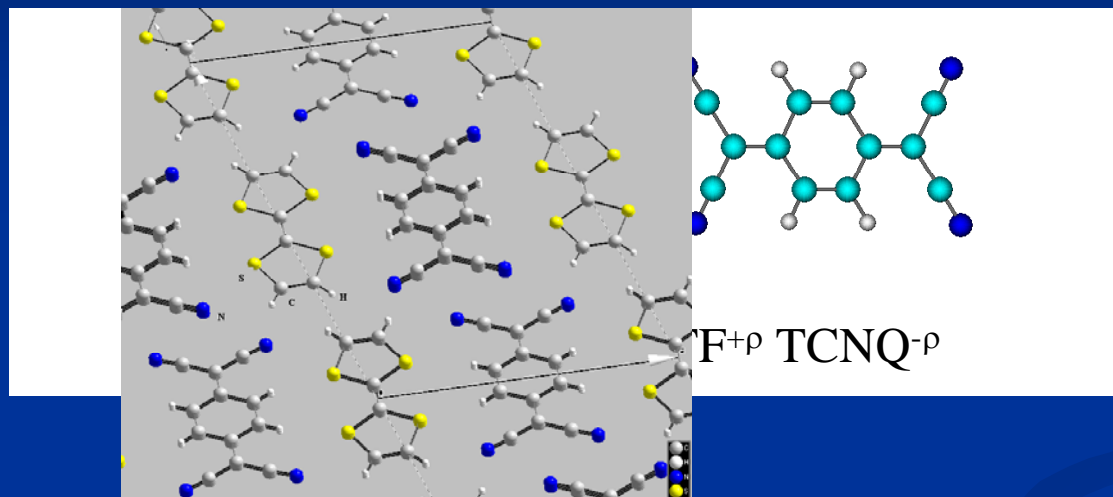

1979: K. Bechgaard

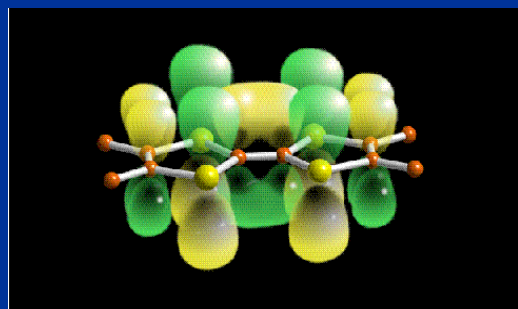

TMTSF



Superconductivity !



Superconductivity !

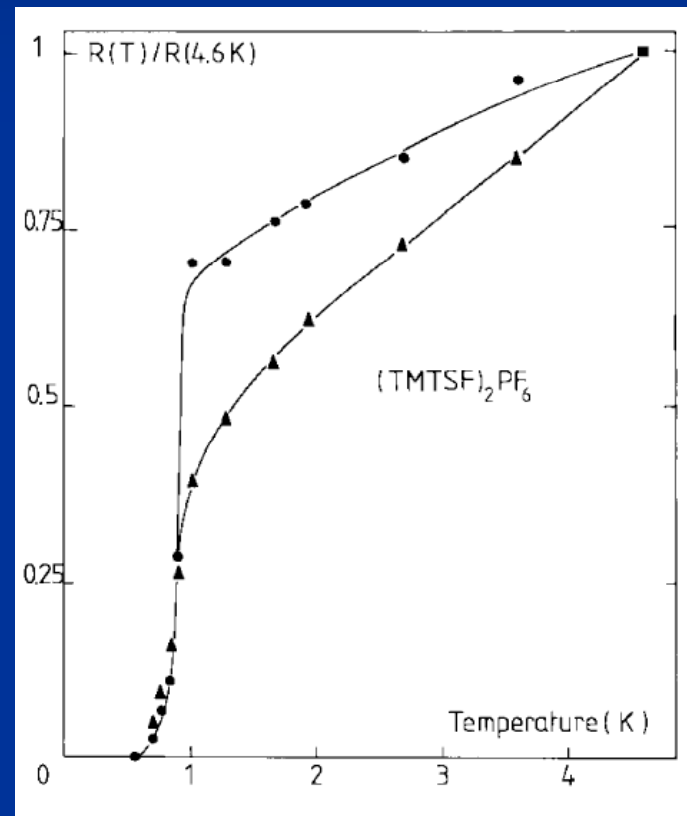

Superconductivity !

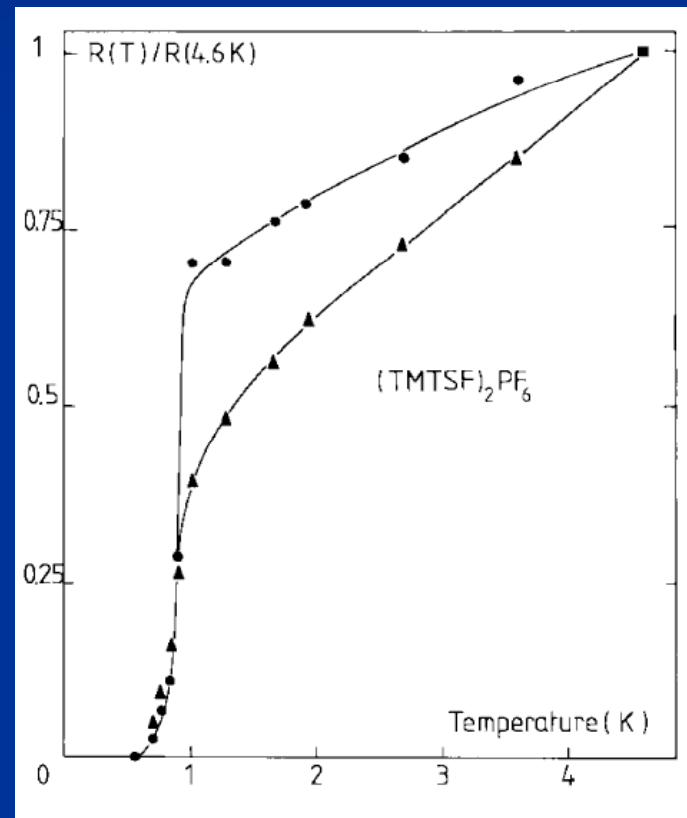

D. Jerome, M. Ribault, J. Mazaud and K. Bechgaard (1980)

Organic conductors

Organic conductors

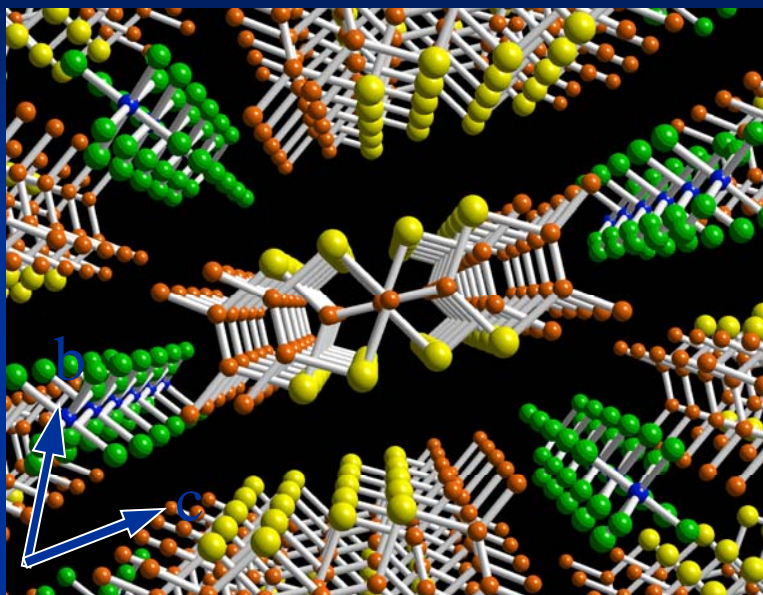

Organic conductors

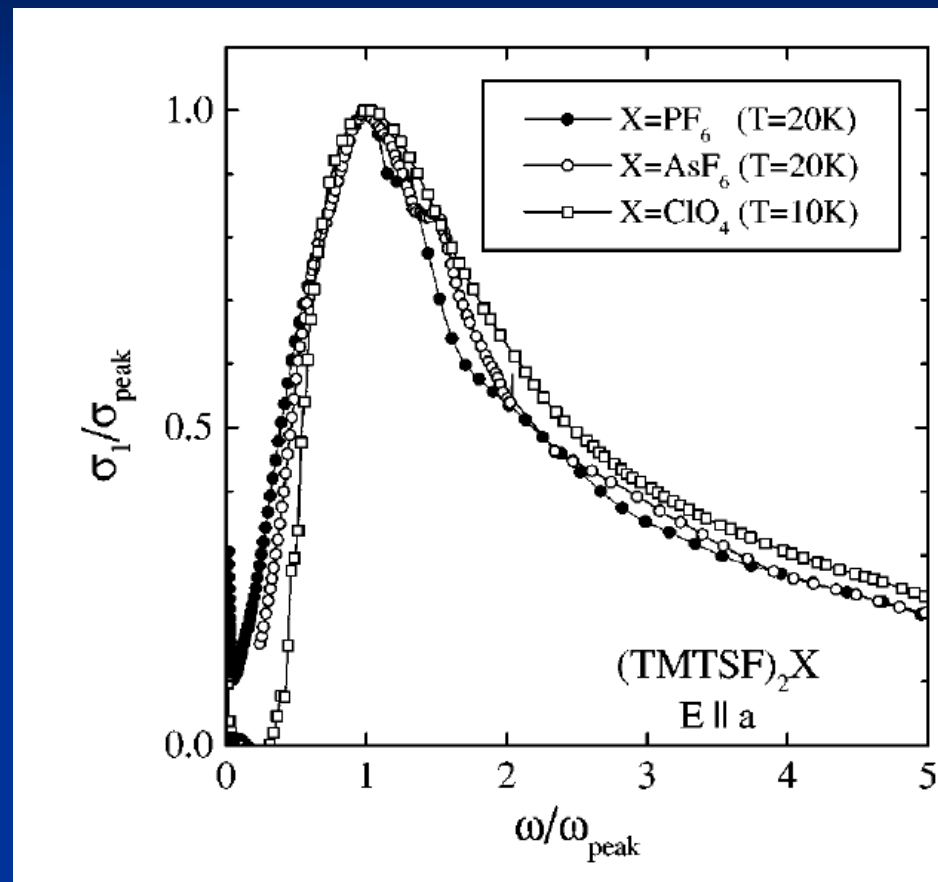
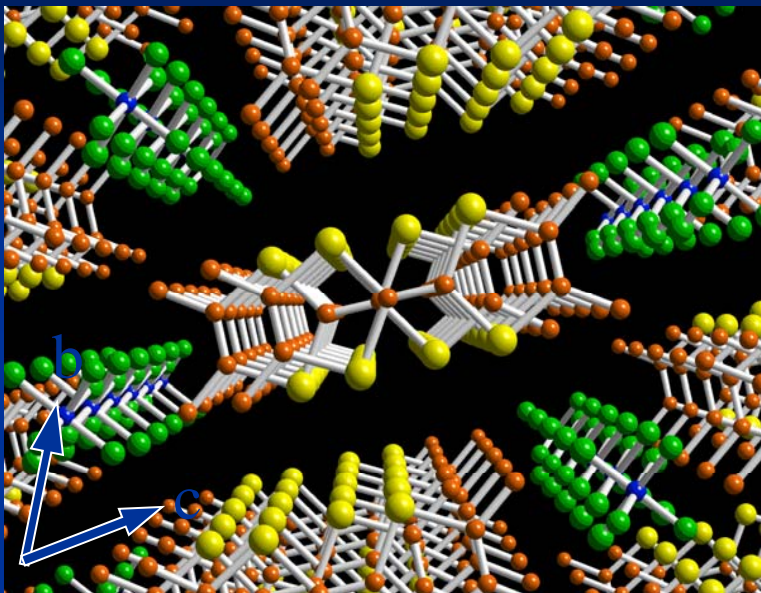

Organic conductors

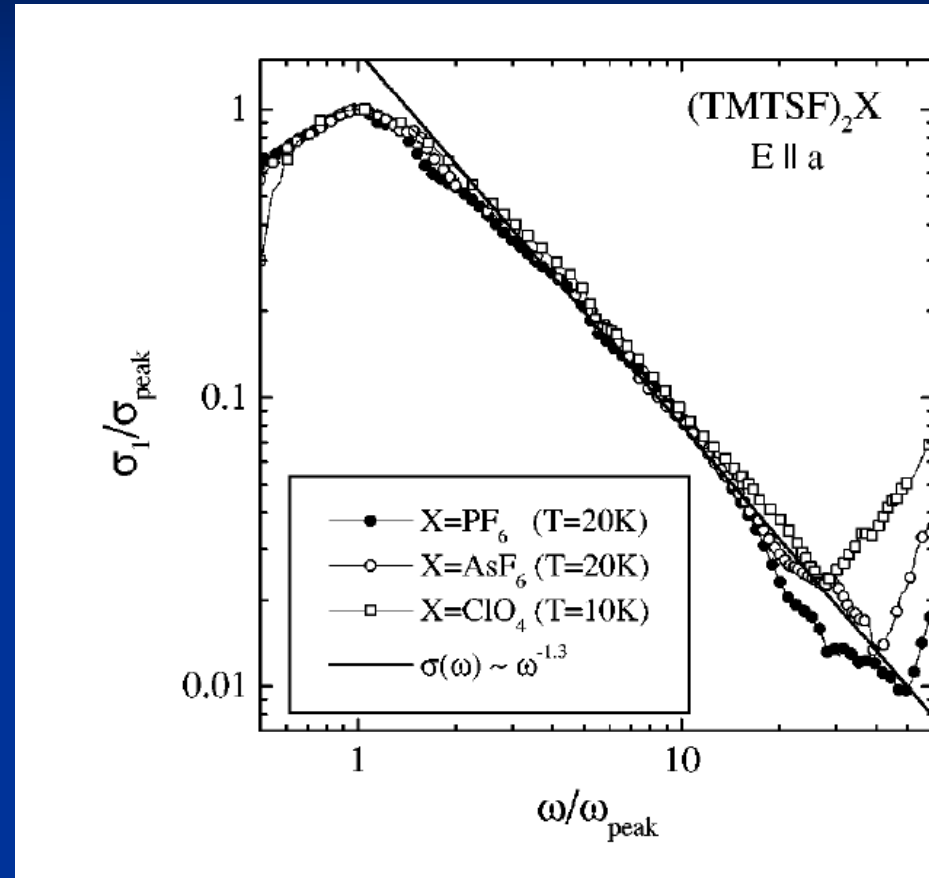
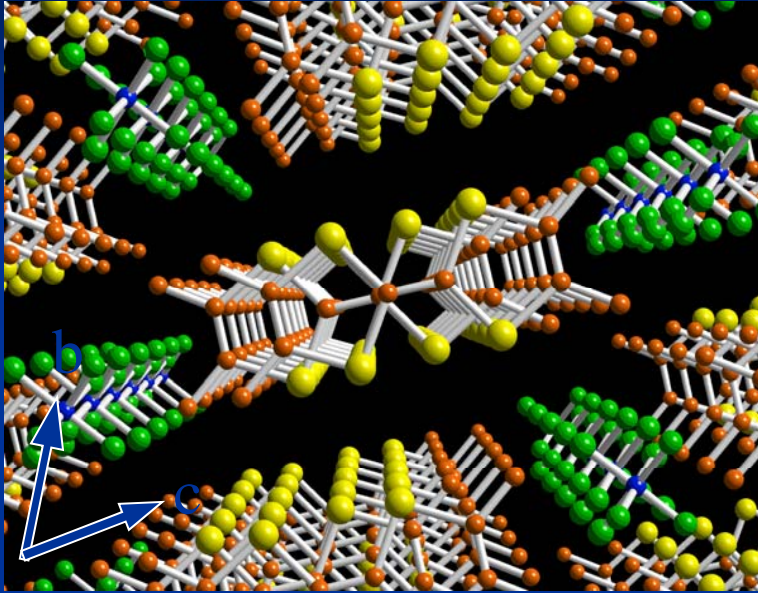

A. Schwartz et al. PRB 58
1261 (1998)

Organic conductors

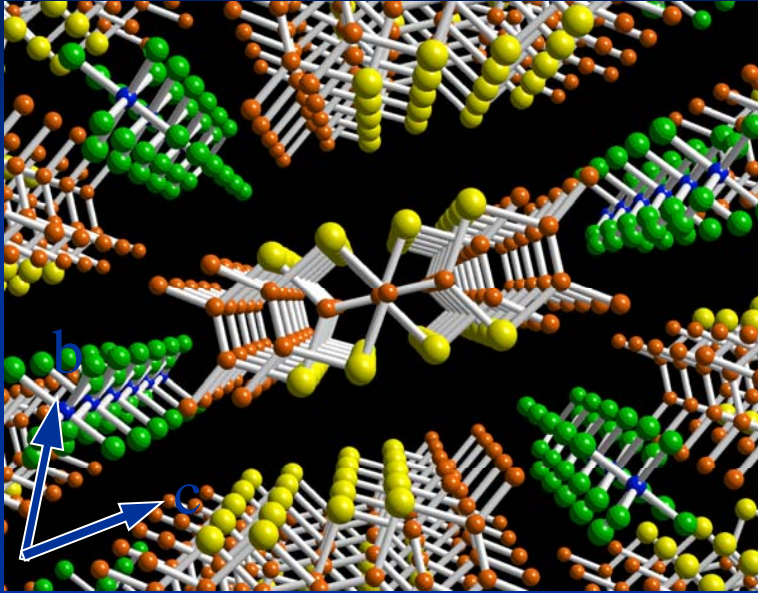

$$\sigma(\omega) \sim \omega^\nu$$

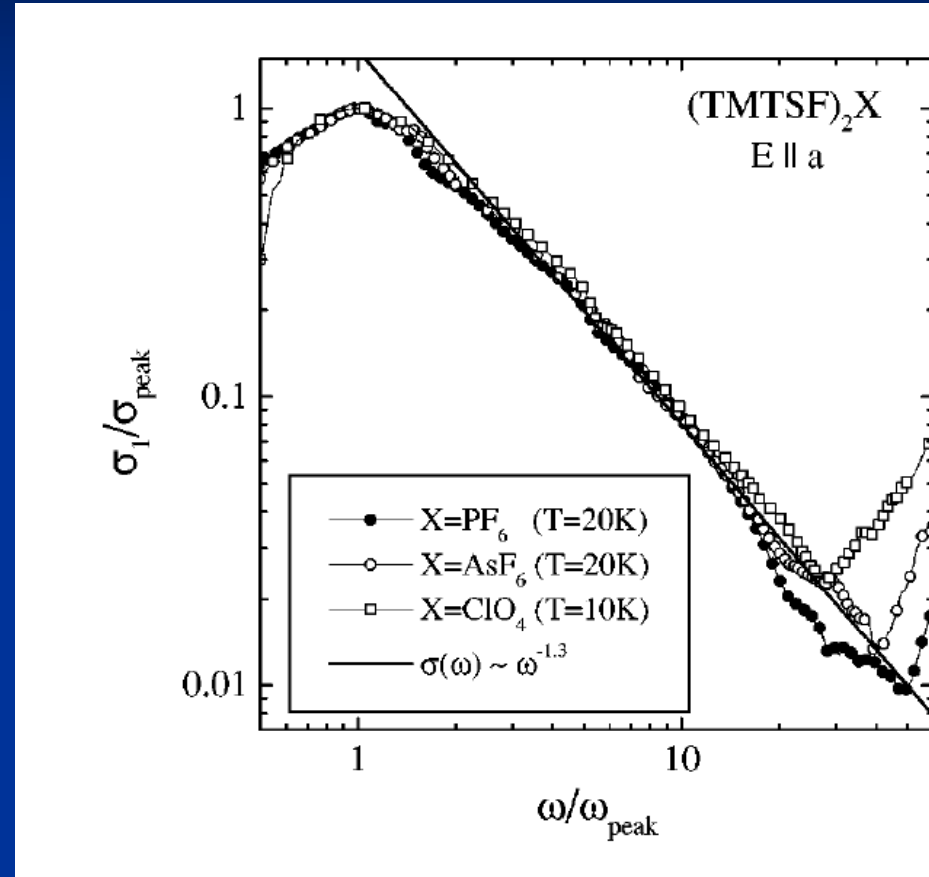

A. Schwartz et al. PRB 58
1261 (1998)

Organic conductors

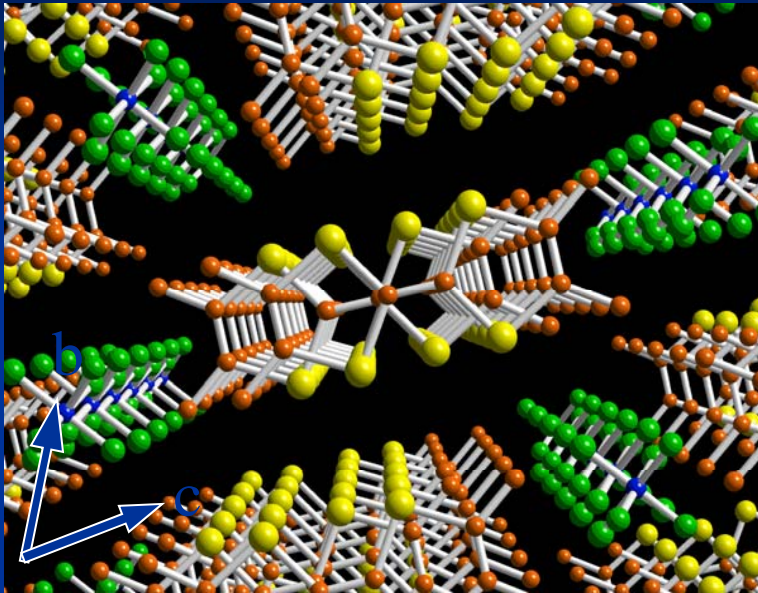

$$\sigma(\omega) \sim \omega^\nu$$

TG PRB (91) :

Physica B 230 (1996)

First observation of LL !!

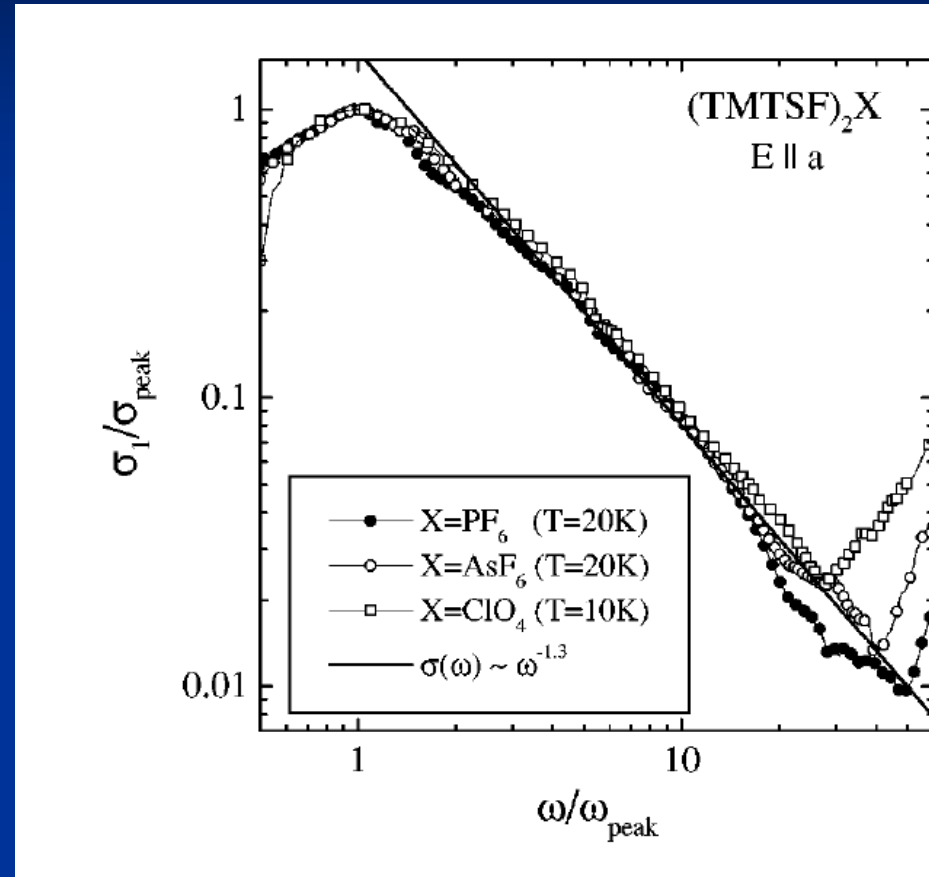

A. Schwartz et al. PRB 58
1261 (1998)

Organic conductors

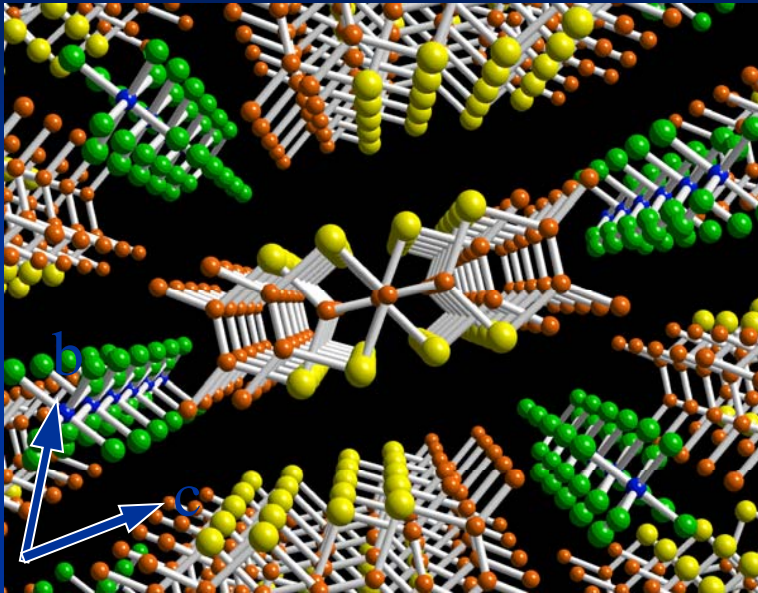

$$\sigma(\omega) \sim \omega^\nu$$

TG PRB (91) :

Physica B 230 (1996)

First observation of LL !!

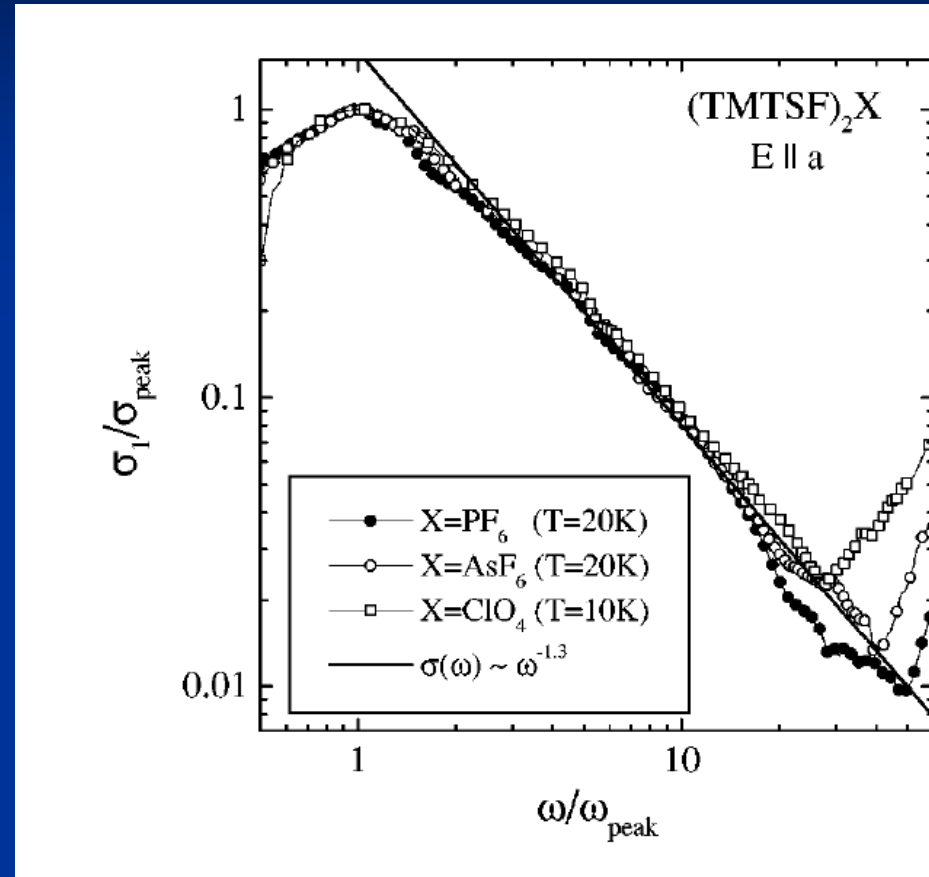

A. Schwartz et al. PRB 58
1261 (1998)

Organic conductors

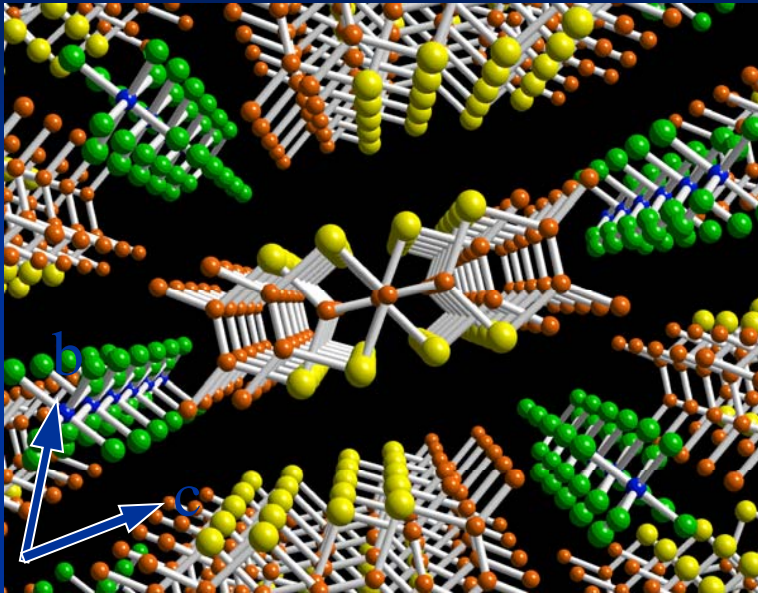

$$\sigma(\omega) \sim \omega^\nu$$

TG PRB (91) :

Physica B 230 (1996)

First observation of LL !!

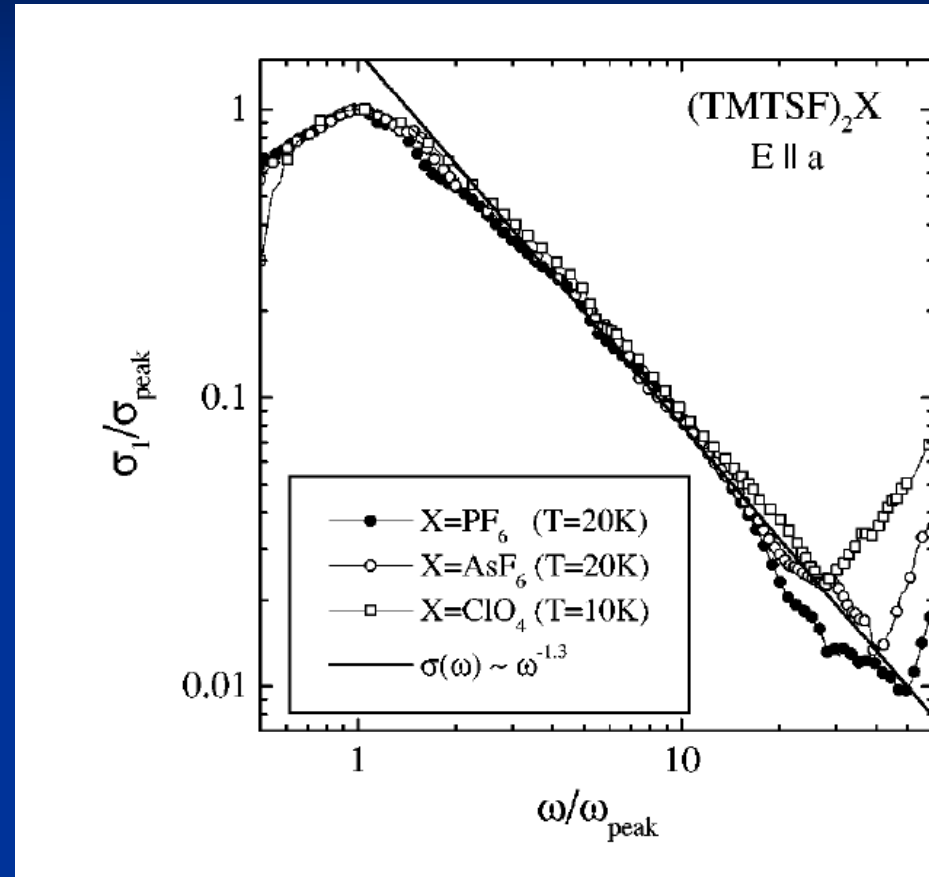

A. Schwartz et al. PRB 58
1261 (1998)

CARBON NANOTUBES



Cees Dekker

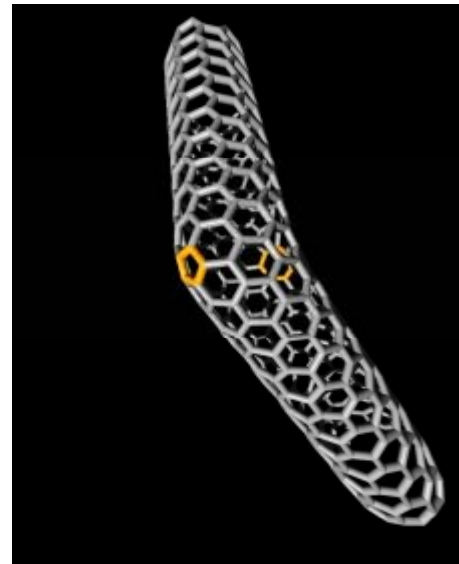
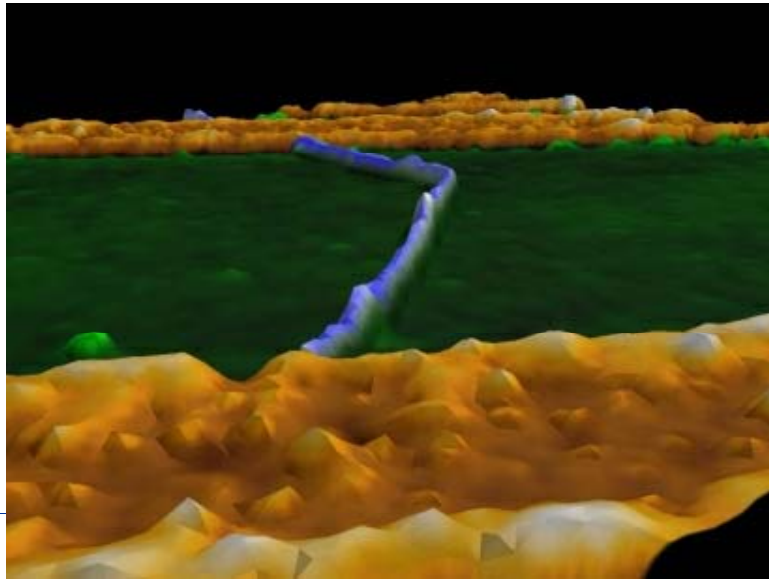
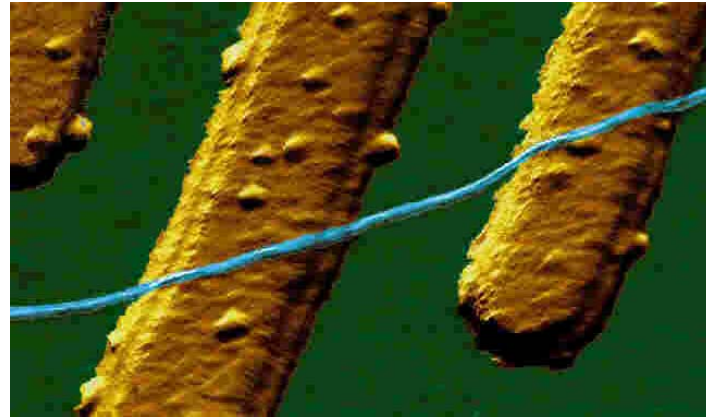

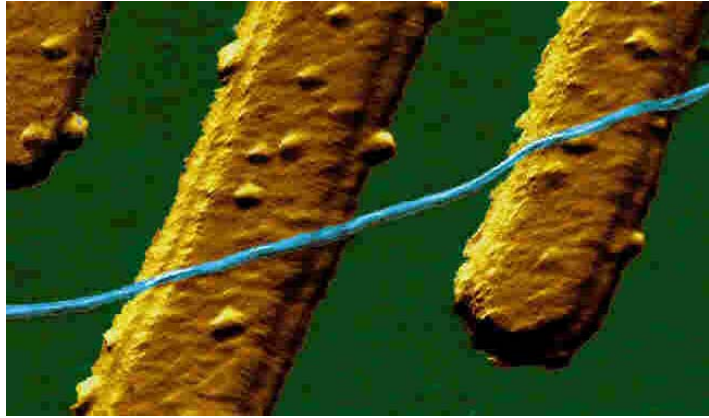

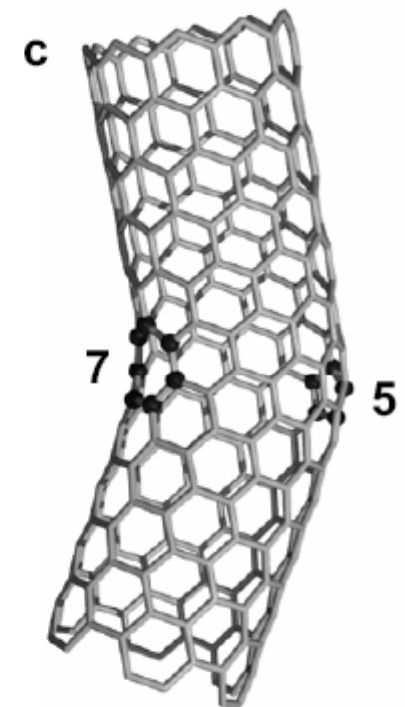
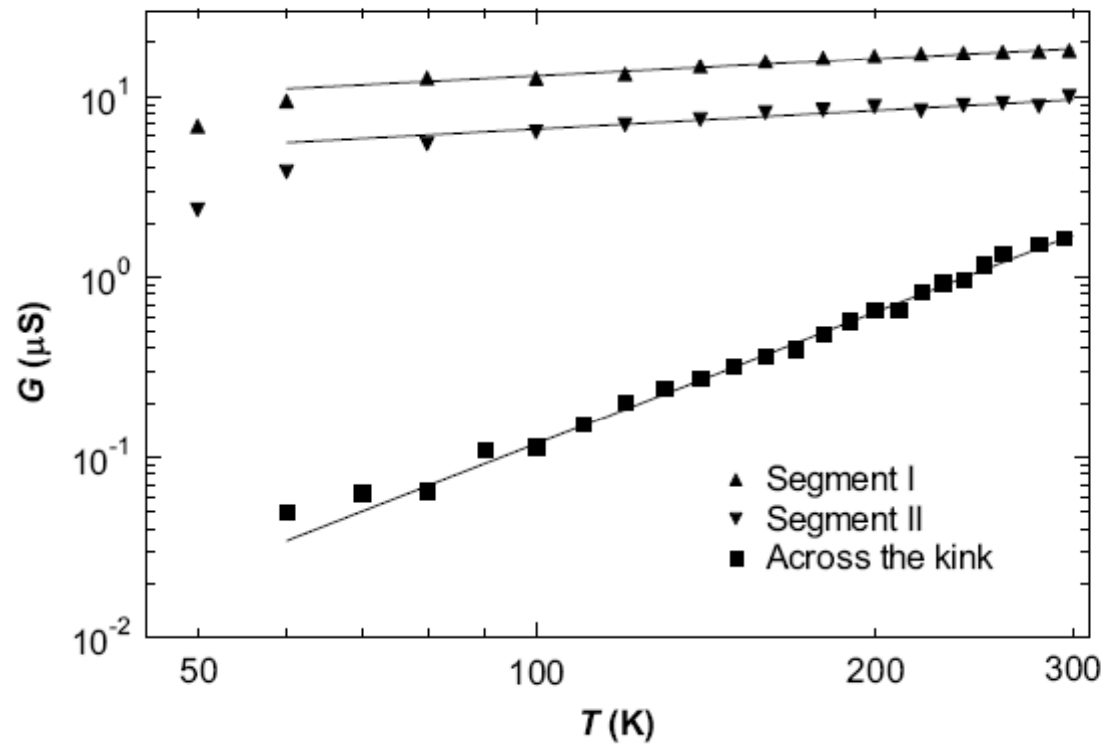
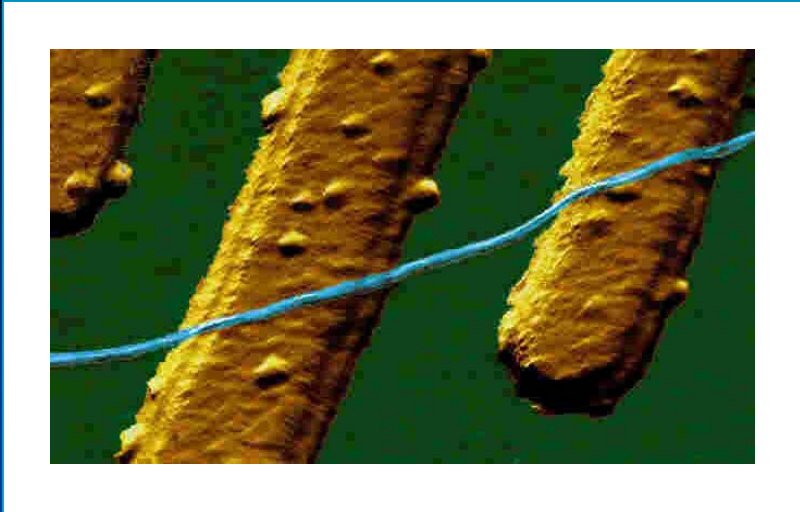

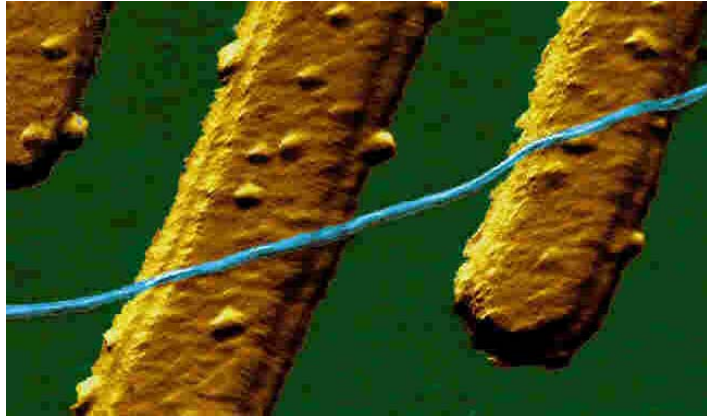

Z. Yao et al. Nature 402
273 (1999)

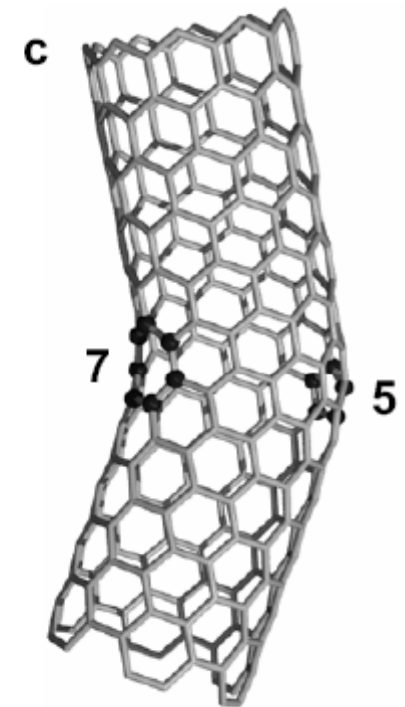
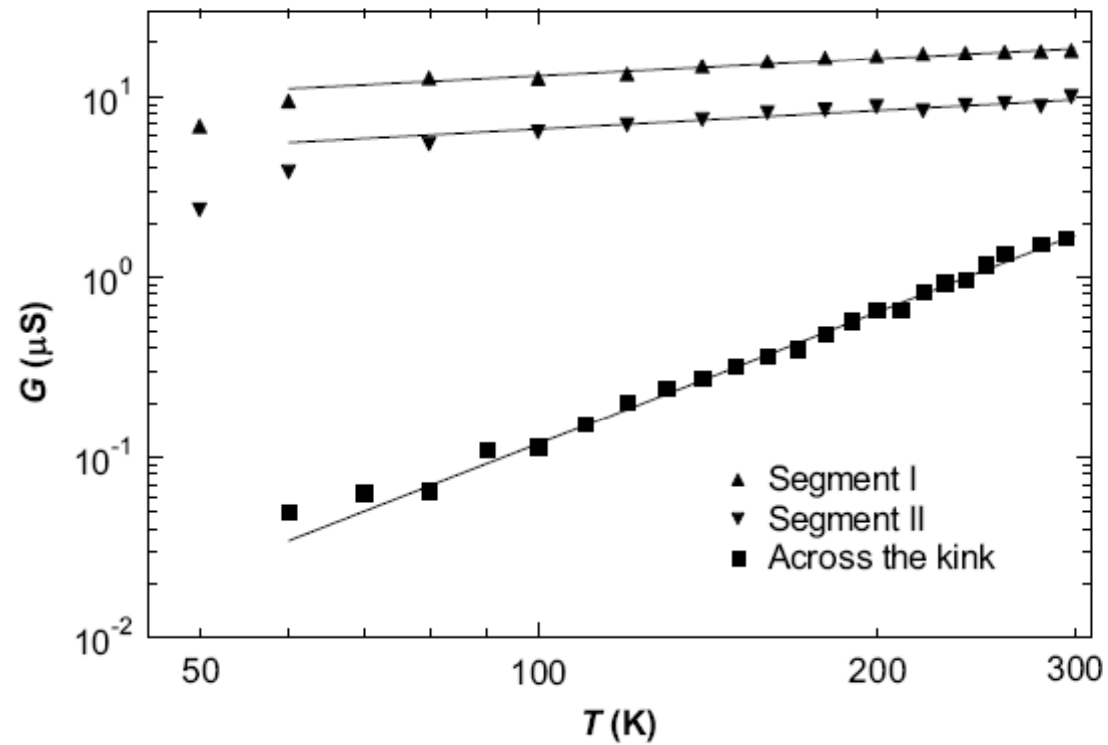

Quantum wires

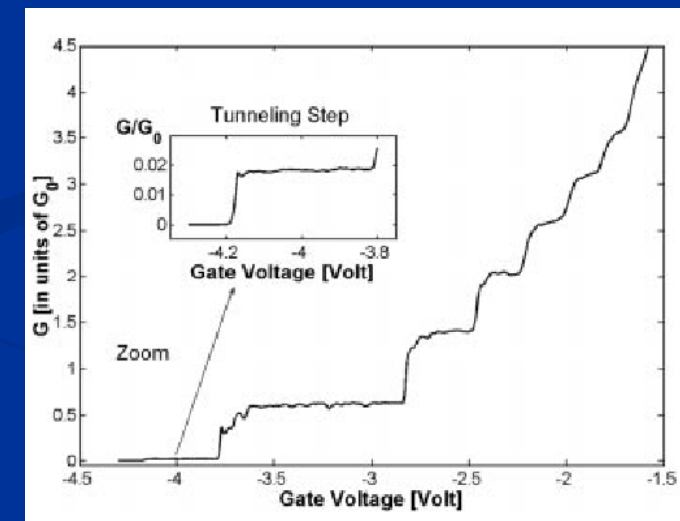
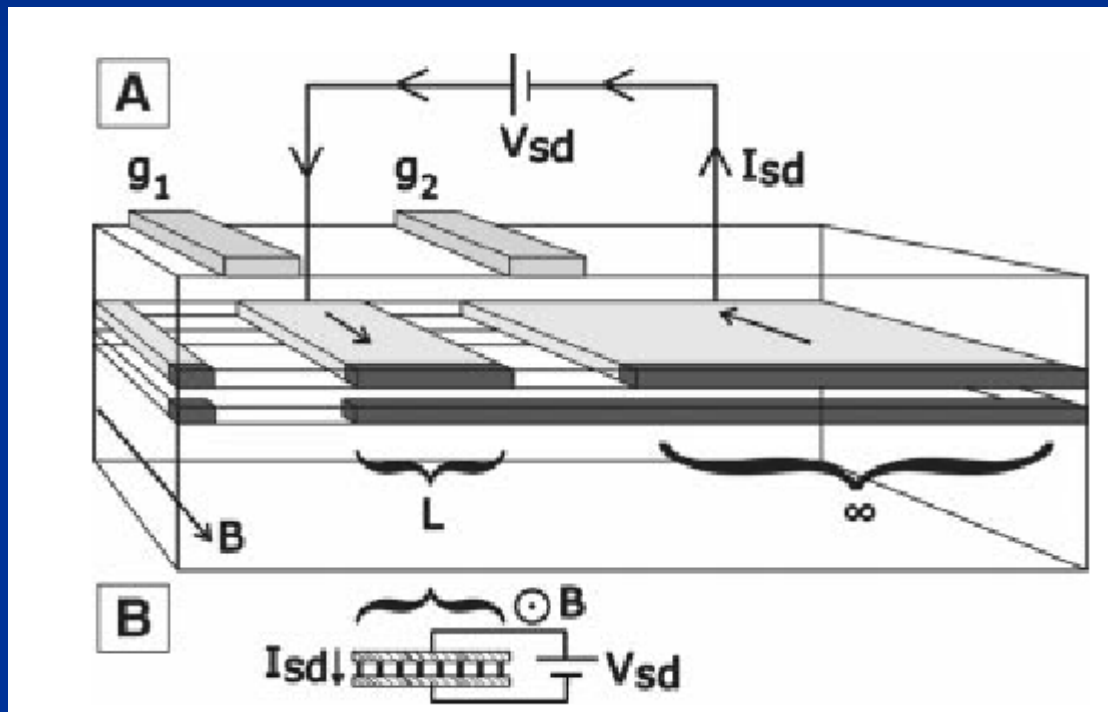

O.M Auslander et al., Science **298** 1354 (2001)
Y. Tserkovnyak et al., PRL **89** 136805 (2002)
Y. Tserkovnyak et al., PRB **68** 125312 (2003)

Amir Yacoby et al. (quantum wires)

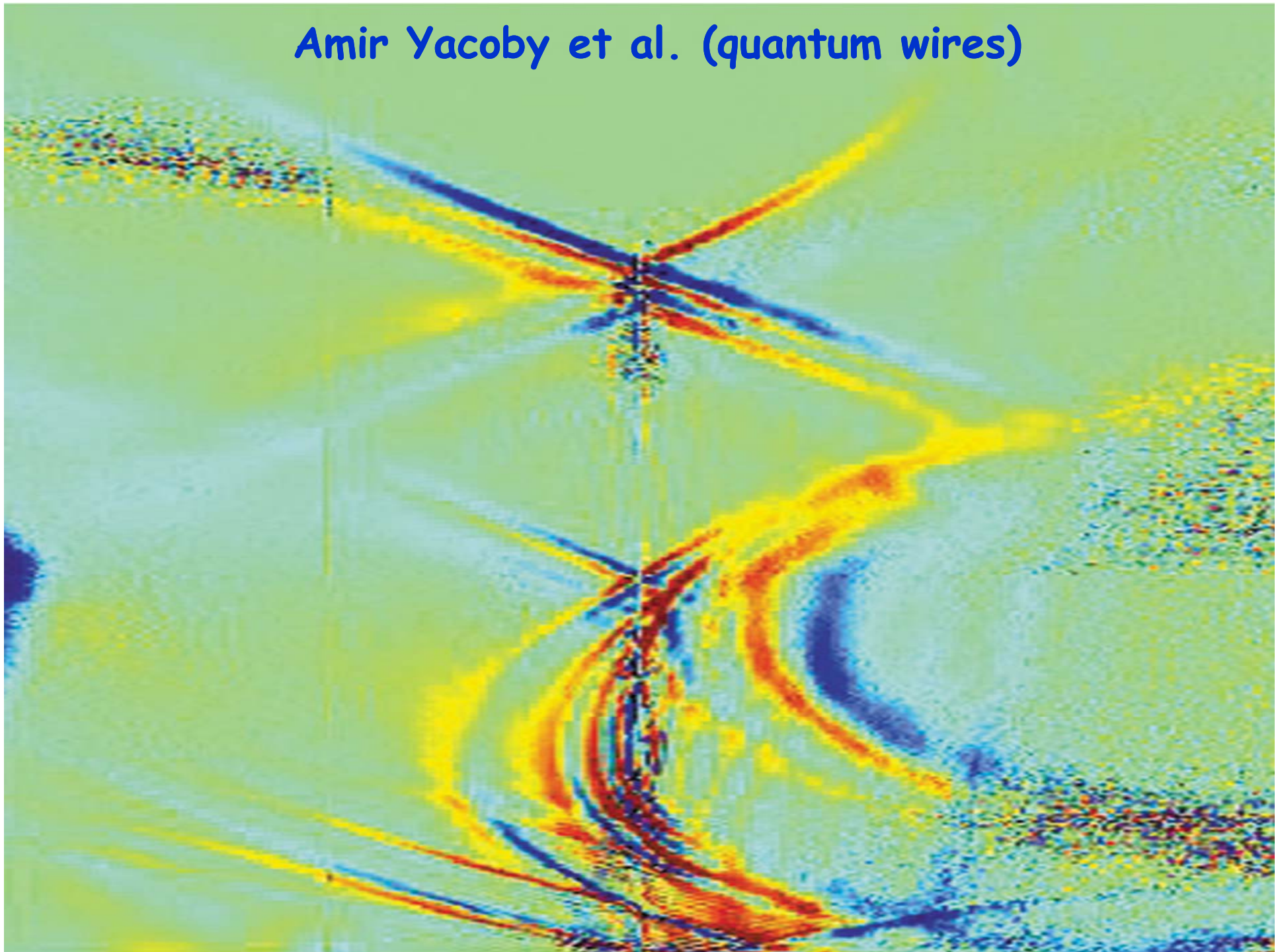

Yacoby et al. (quantum wires)

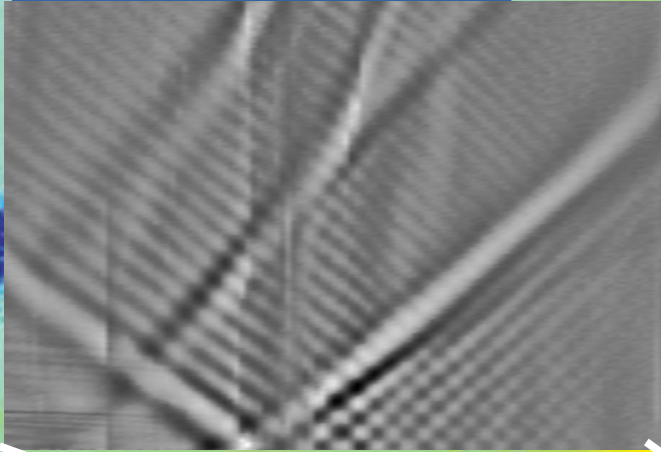
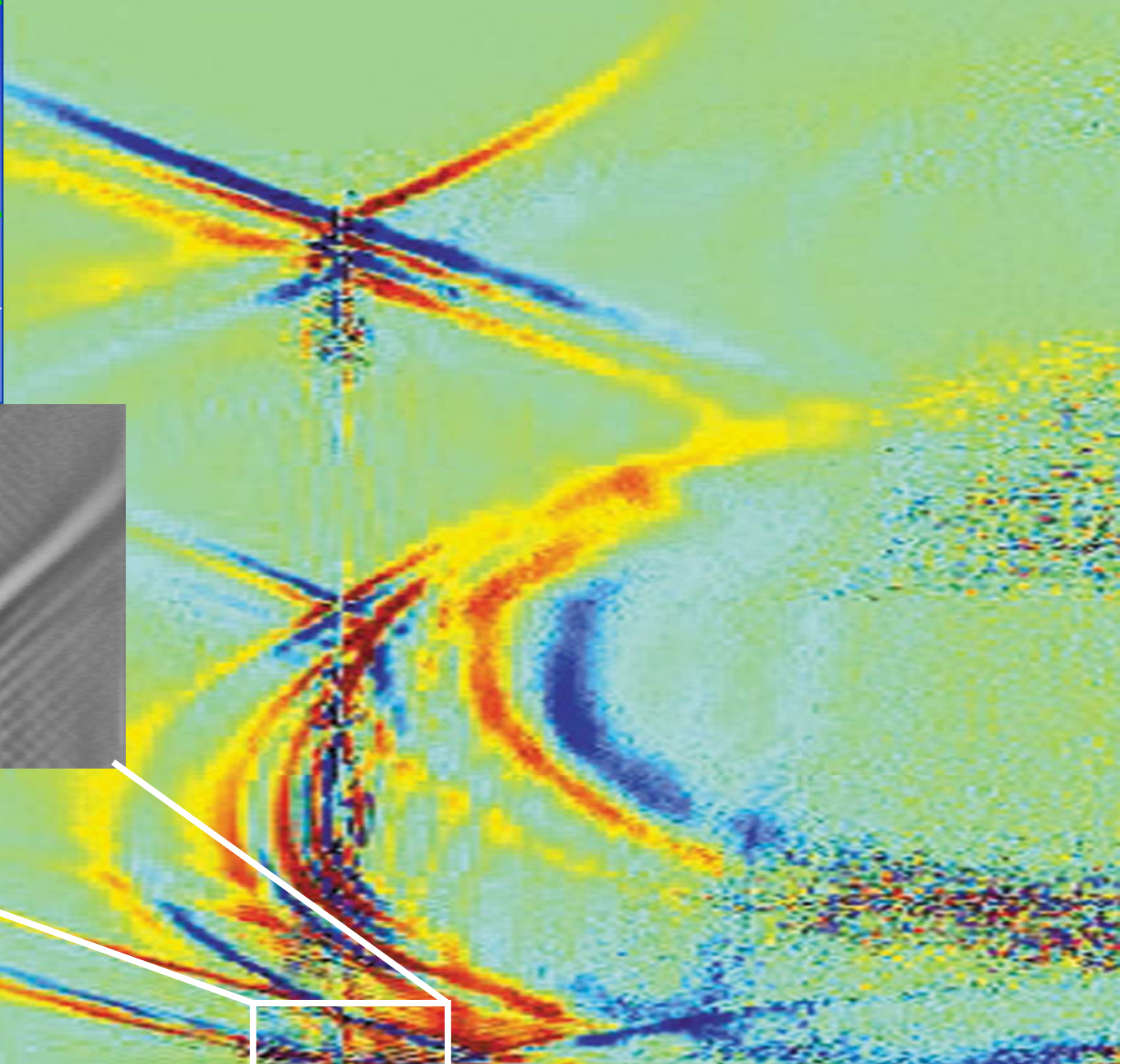
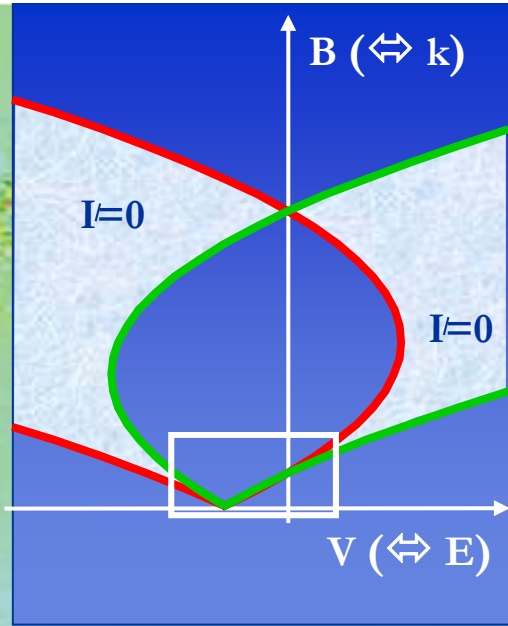

Yacoby et al. (quantum wires)

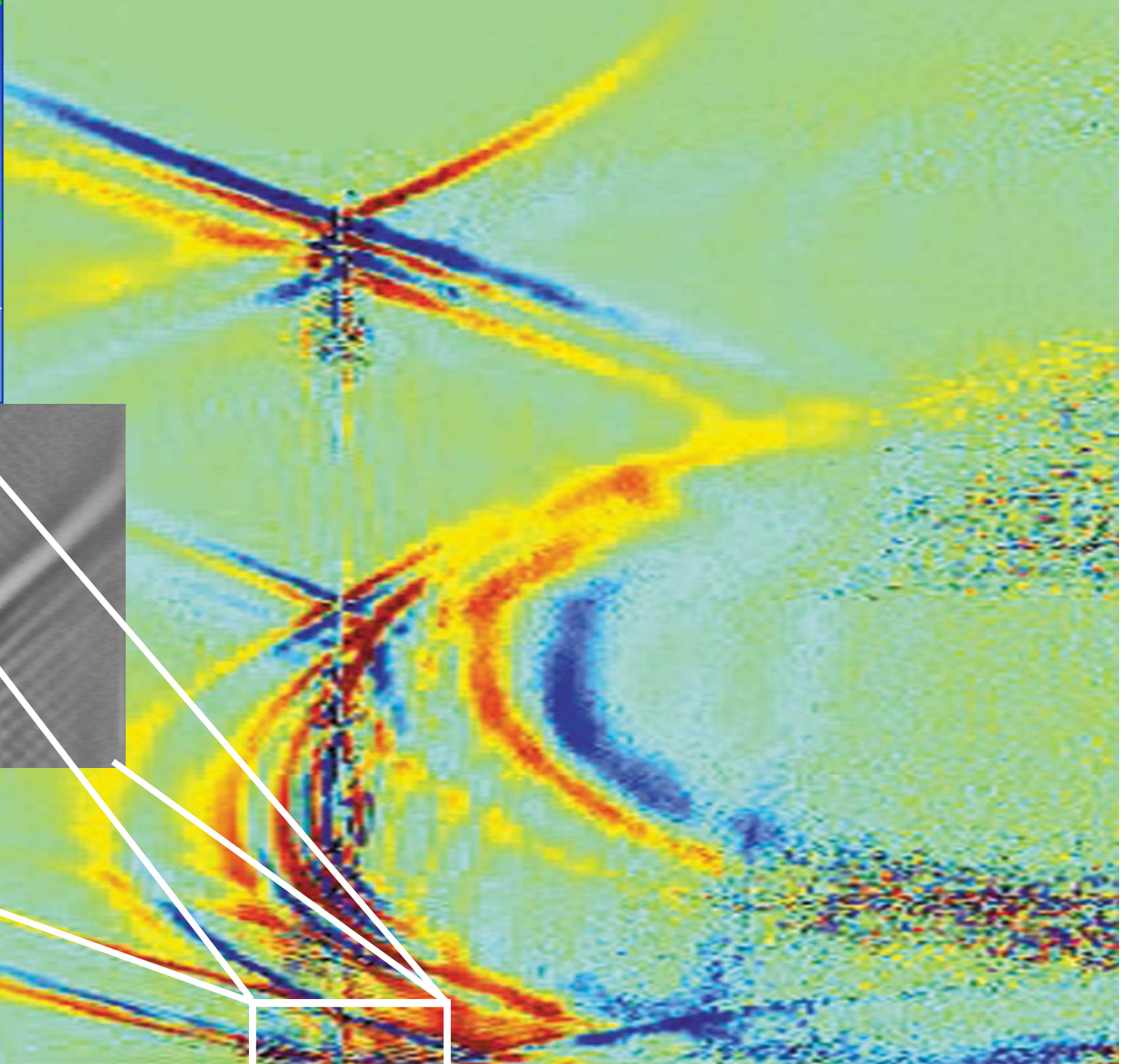
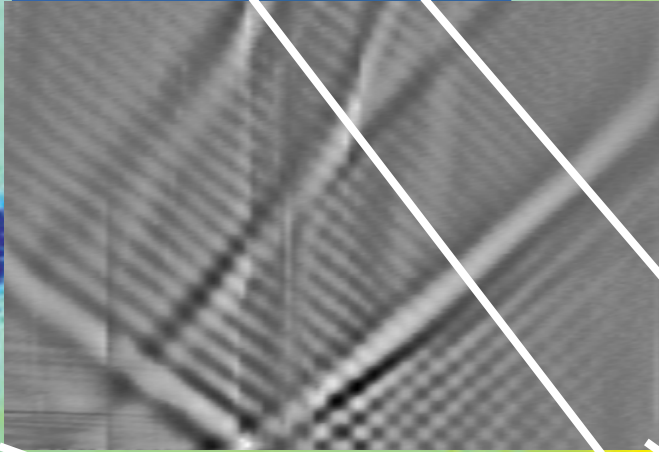
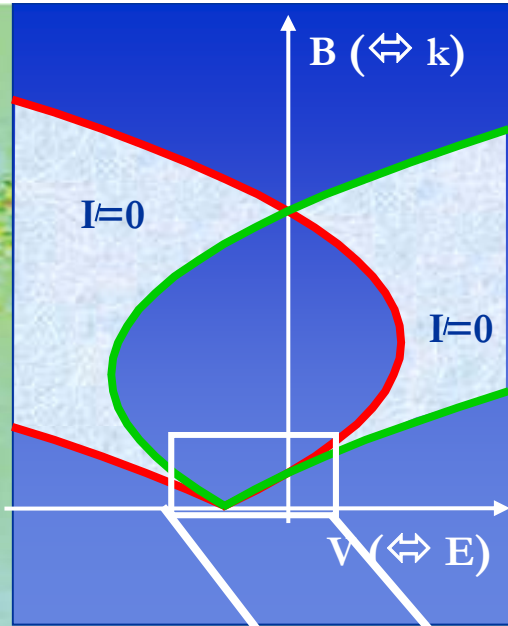

Yacoby et al. (quantum wires)

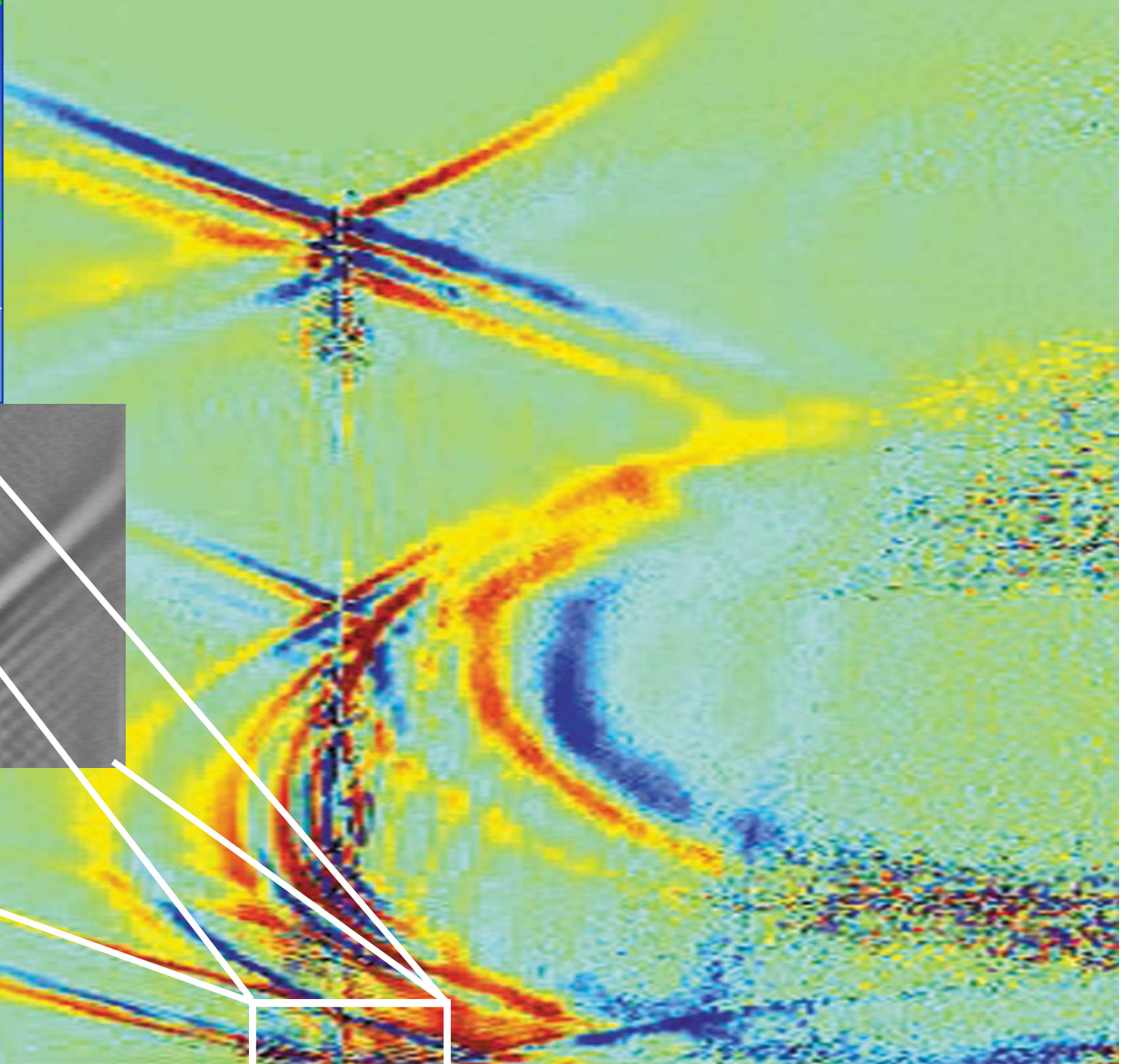
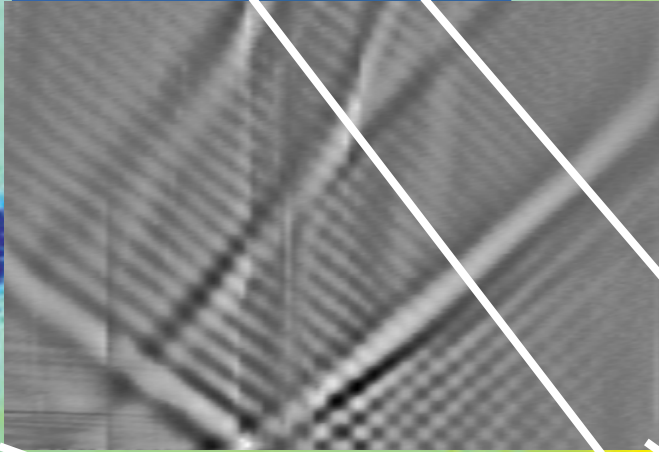
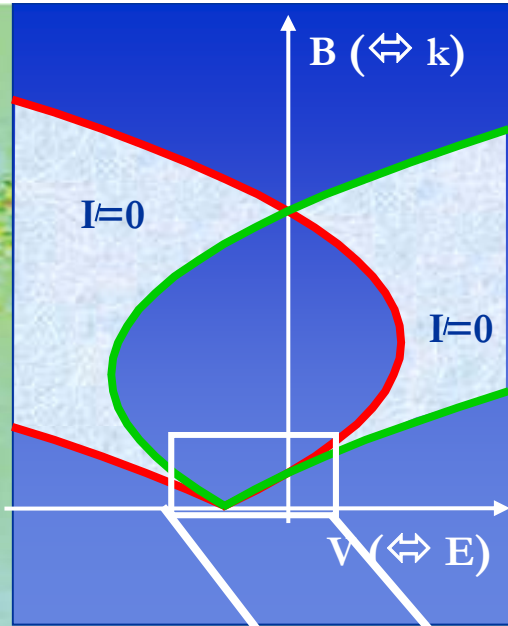

Yacoby et al. (quantum wire)

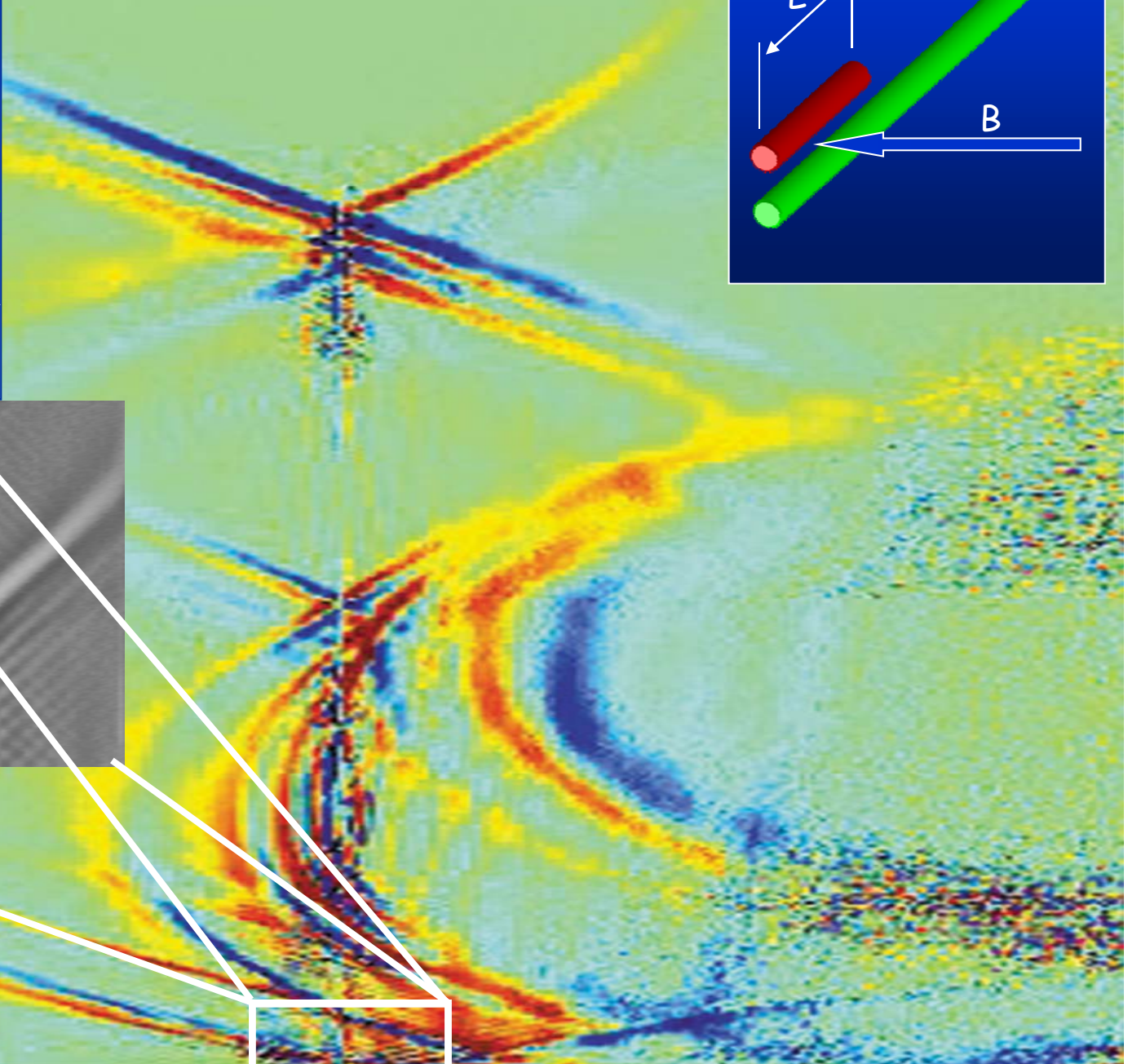
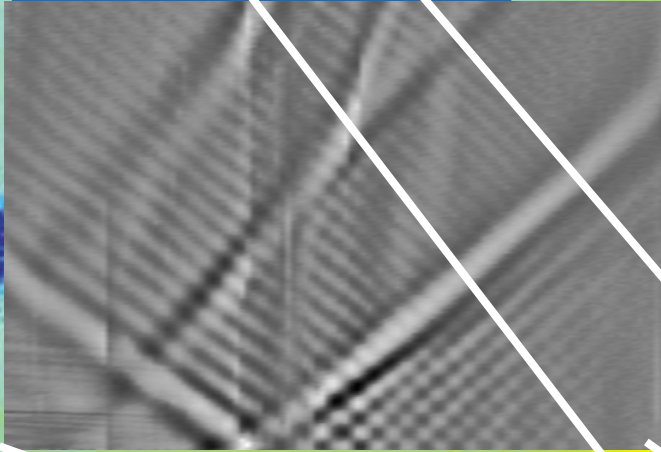
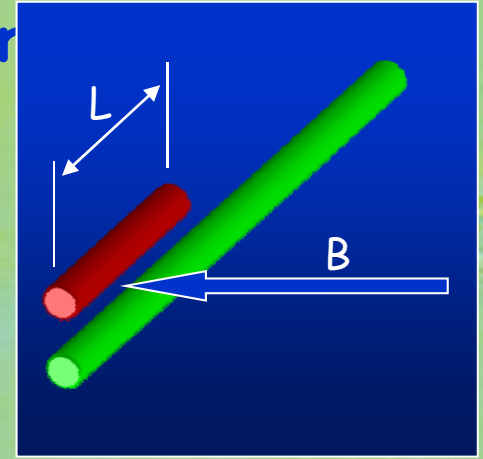
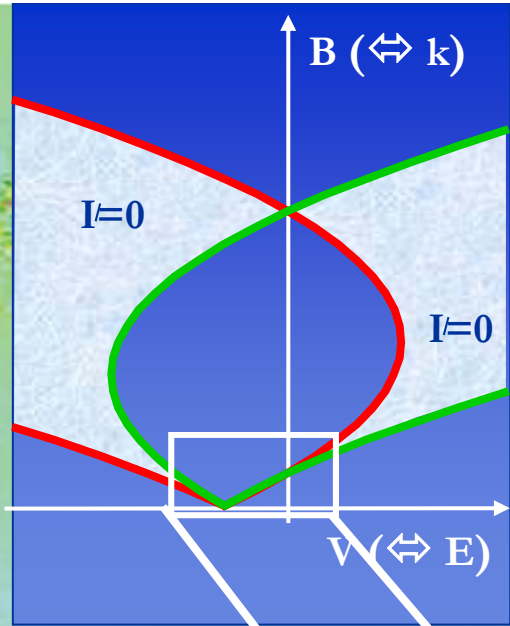

Cold atomic gases

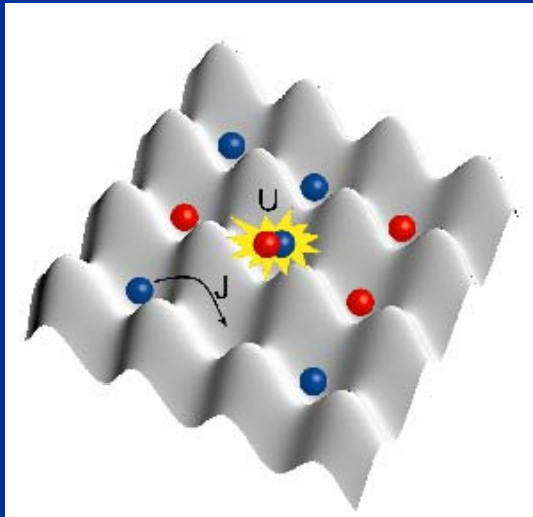

Cold atomic gases

- Novel “materials” to address condensed matter issues
- Extreme control and versatility

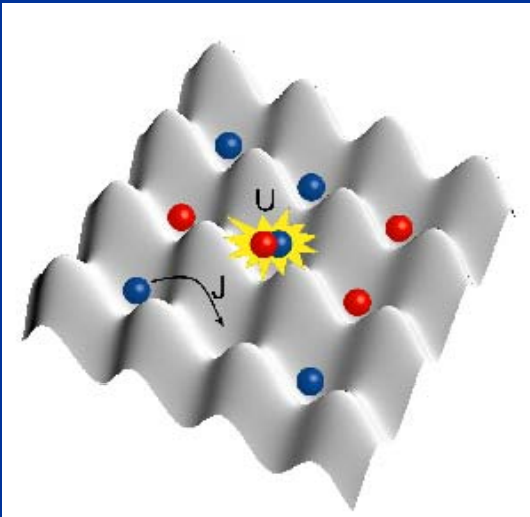

Cold atomic gases

- Novel “materials” to address condensed matter issues
- Extreme control and versatility

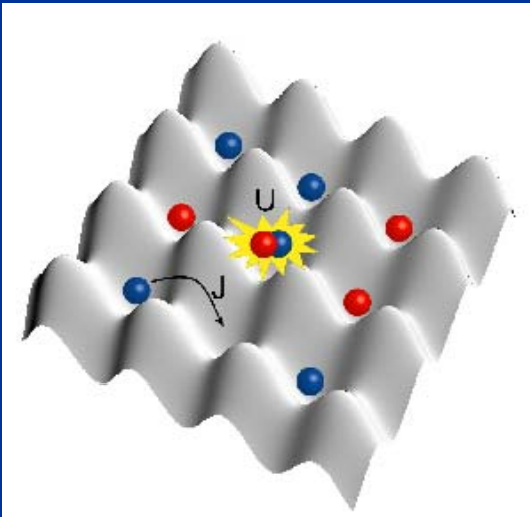

Cold atomic gases

- Novel “materials” to address condensed matter issues
- Extreme control and versatility

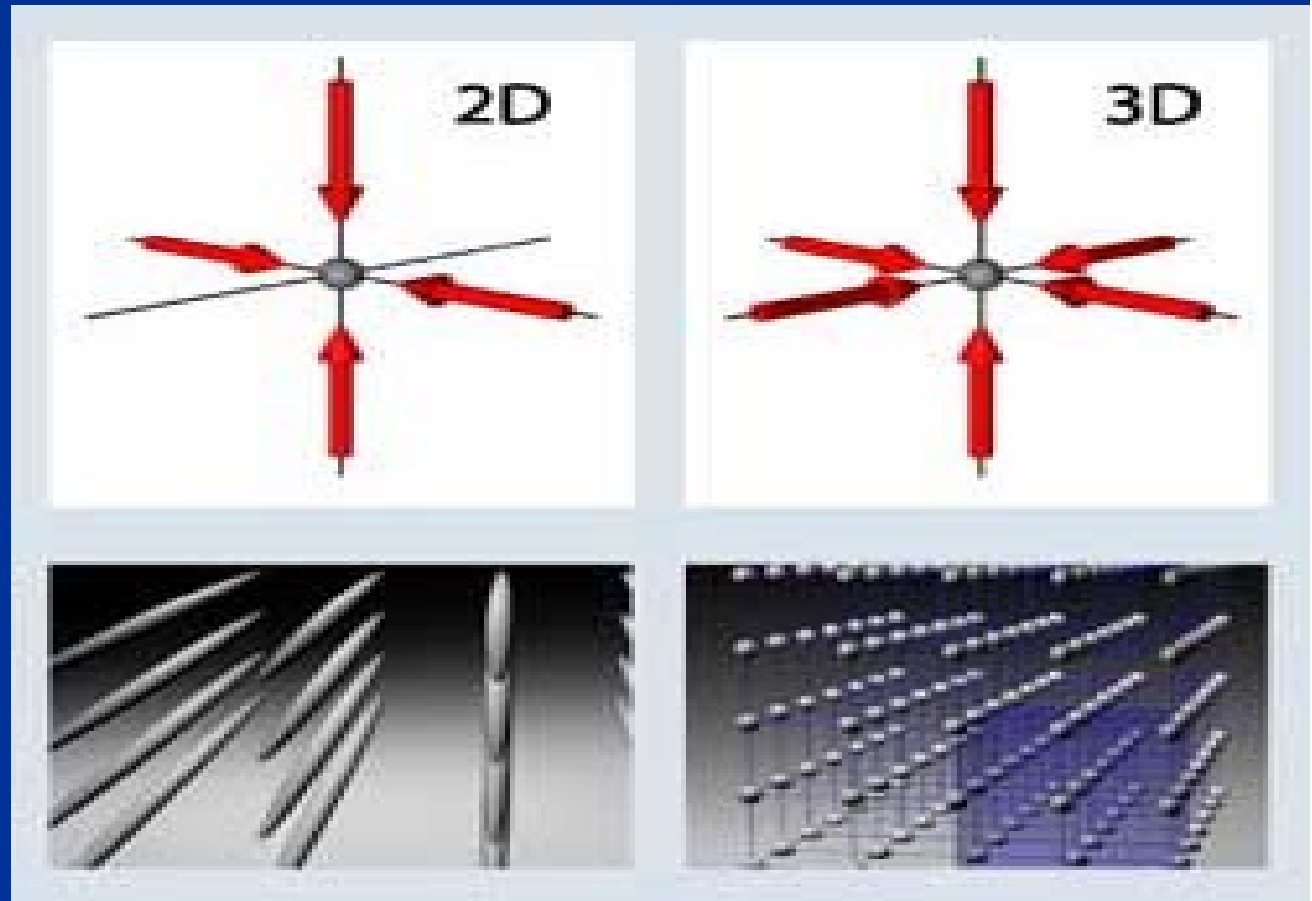
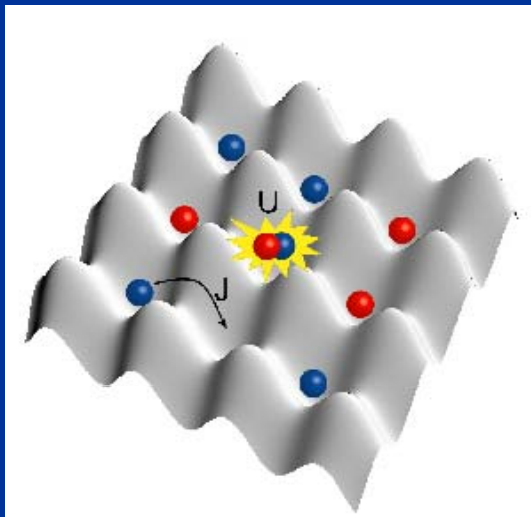

Cold atoms (Tonks limit)



B. Paredes et al., Nature 429 277 (2004)

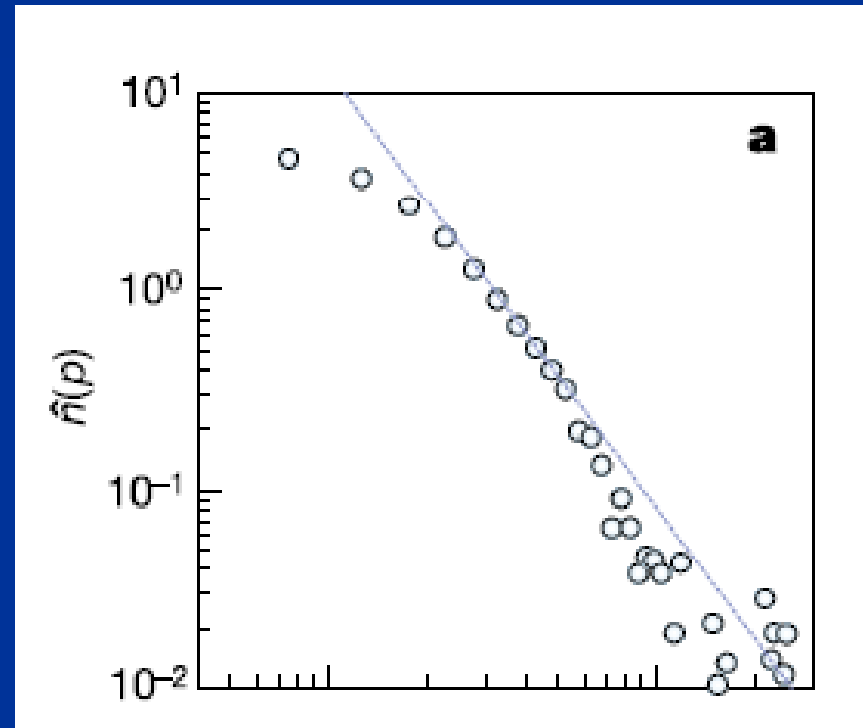
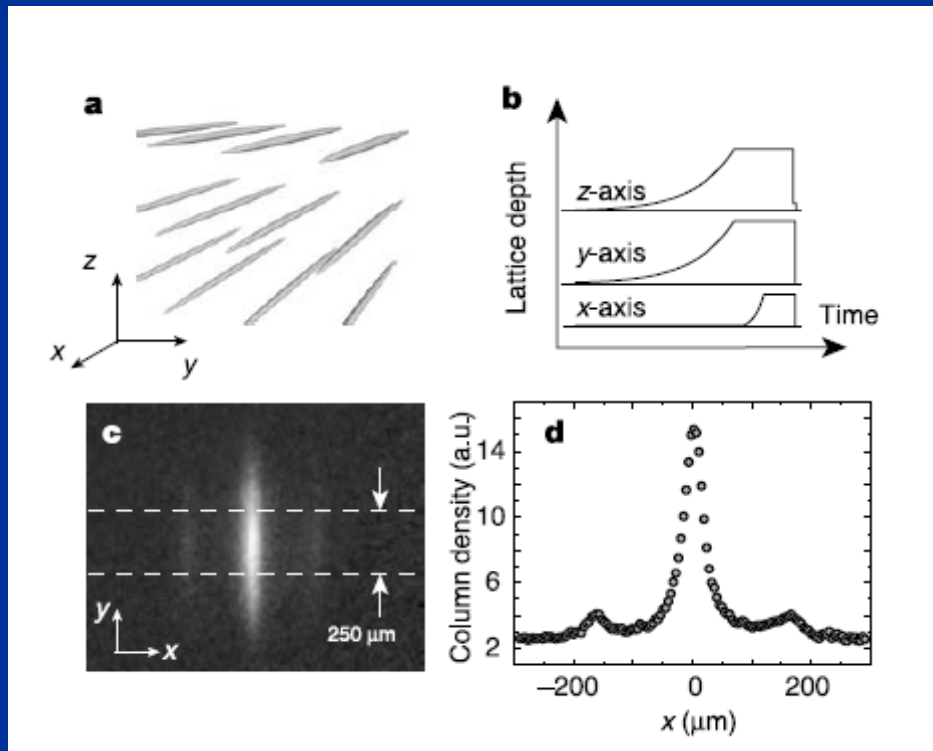

Cold atoms: Interferences

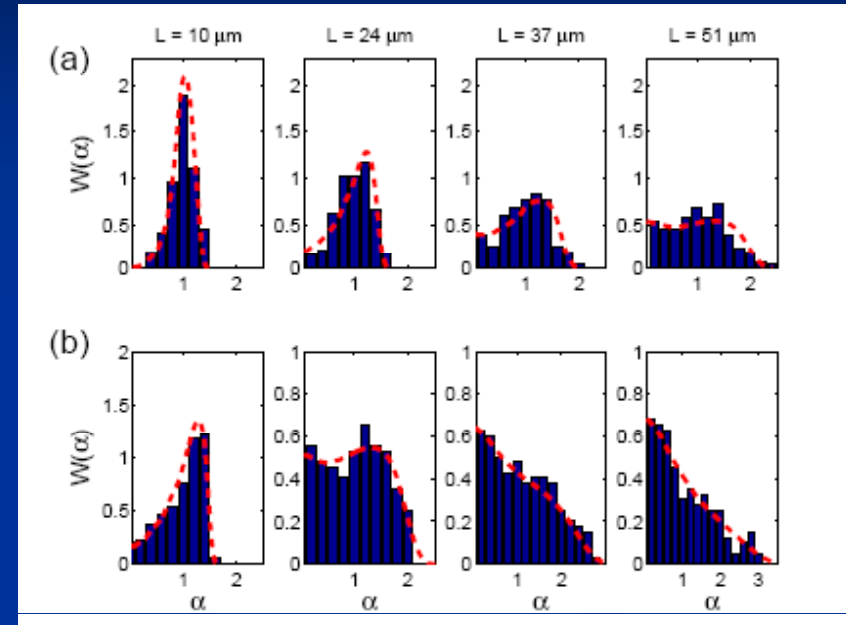
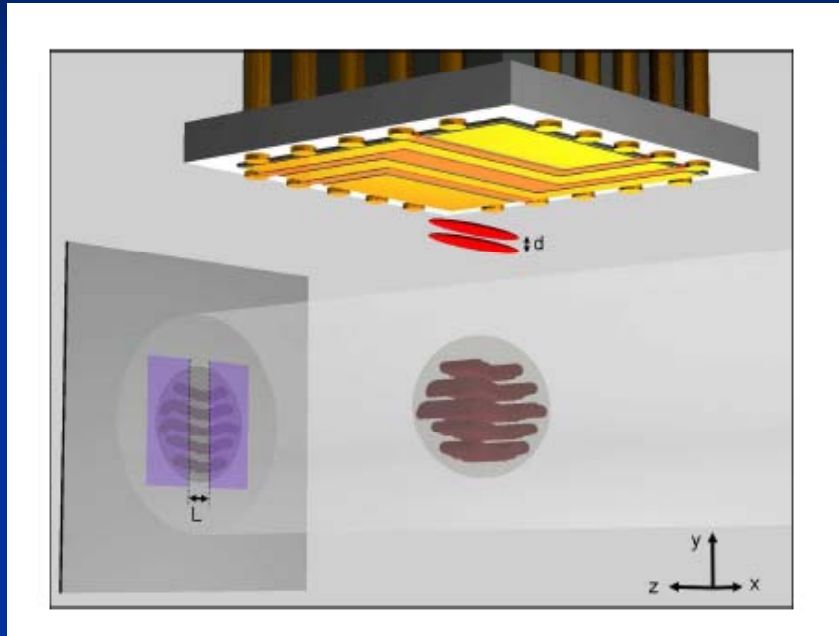

S. Hofferberth et al. Nat. Phys 4
489 (2008)

$$\int_0^L \langle \psi^\dagger(\mathbf{r}) \psi(0) \rangle$$

but K large (42) $\rho \sim \rho_0$ hydrodynamic ?

But.....

But.....

- Exponent is an adjustable parameter

But.....

- Exponent is an adjustable parameter
- Universality ? Different correlation functions ?

But.....

- Exponent is an adjustable parameter
- Universality ? Different correlation functions ?
- Variation with a control parameter ?

But.....

- Exponent is an adjustable parameter
- Universality ? Different correlation functions ?
- Variation with a control parameter ?

can one do a quantitative test ????

Spin ladders

Spin ladders

B. C. Watson et al., PRL 86 5168 (2001)

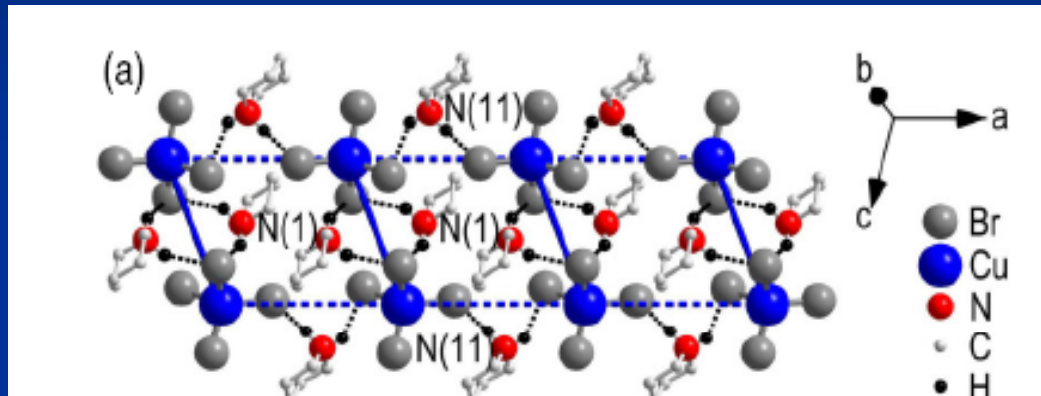

Spin ladders

B. C. Watson et al., PRL 86 5168 (2001)

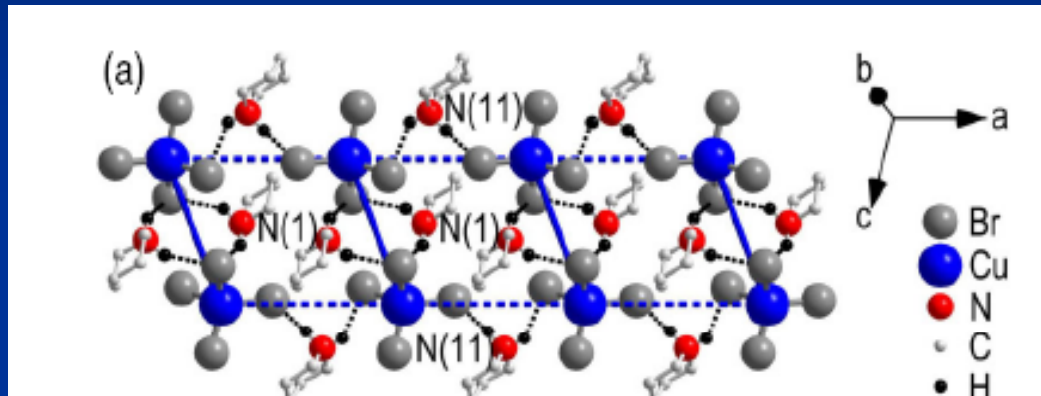

Spin ladders

B. C. Watson et al., PRL 86 5168 (2001)

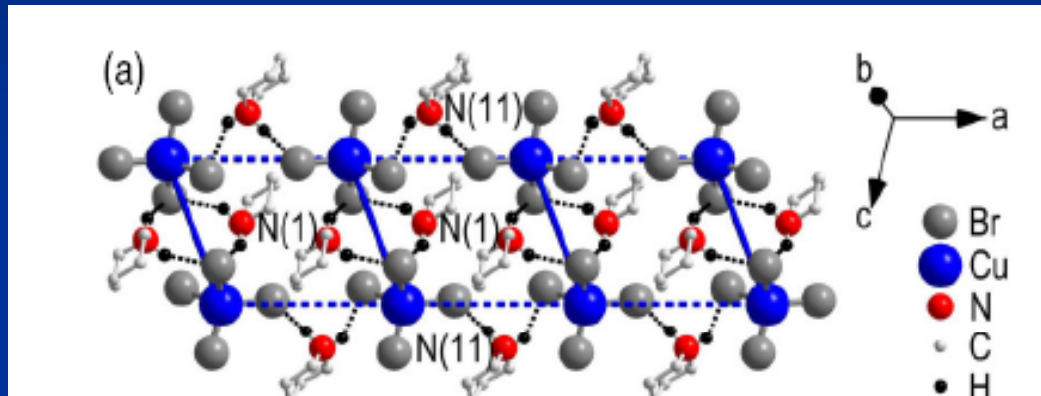

M. Klanjsek et al.,

PRL 101 137207 (2008)

Spin ladders

B. C. Watson et al., PRL 86 5168 (2001)

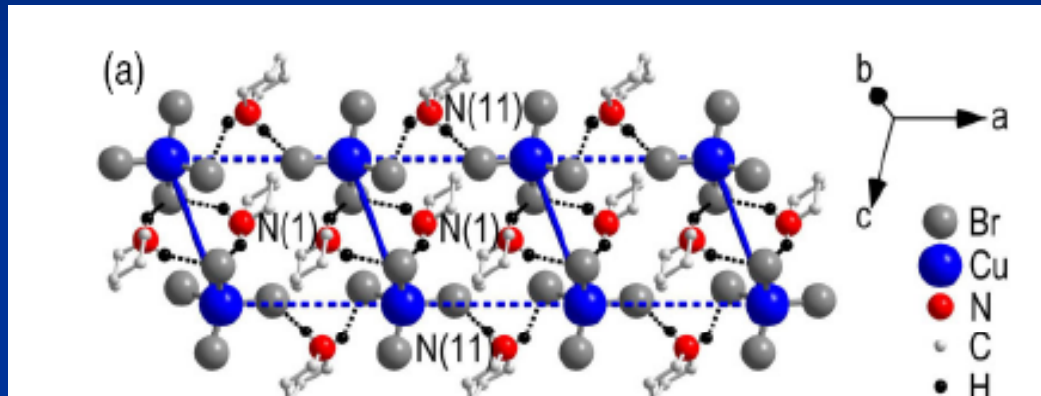

M. Klanjsek et al.,

PRL 101 137207 (2008)

B. Thielemann et al.,

PRB 79, 020408(R) (2009)

Spin ladders

B. C. Watson et al., PRL 86 5168 (2001)

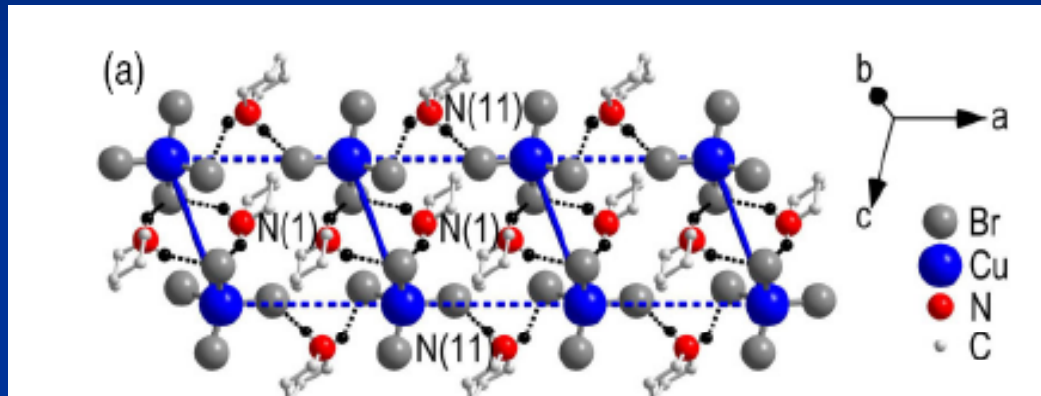

M. Klanjsek et al.,
PRL 101 137207 (2008)

B. Thielemann et al.,
PRB 79, 020408(R) (2009)

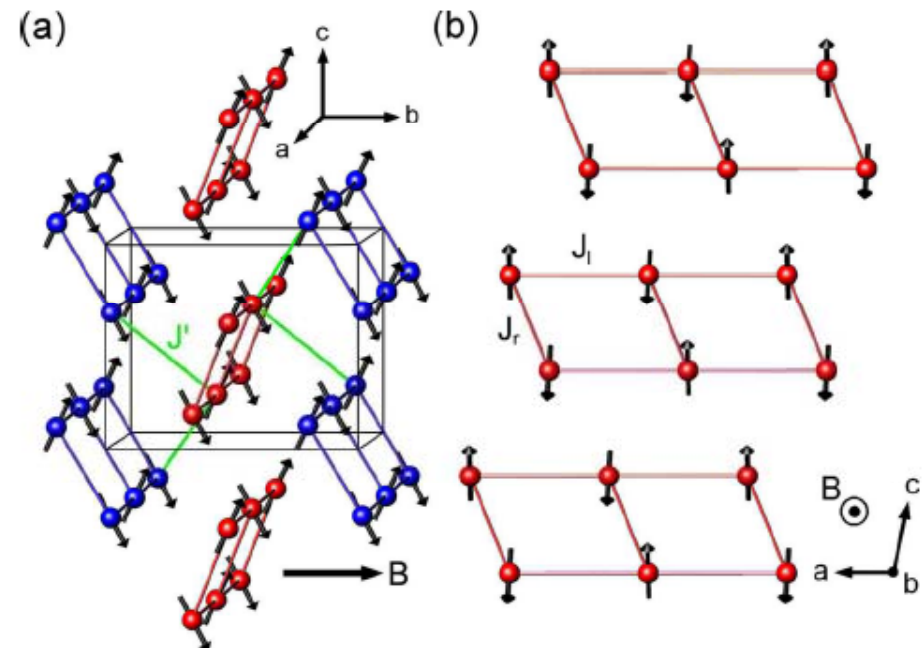

Spin Ladders

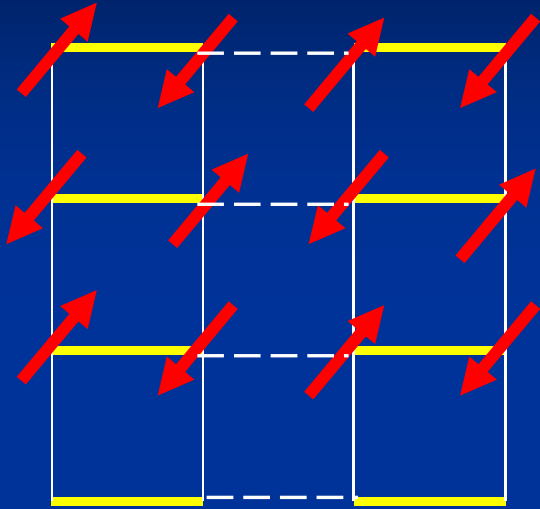

Spin Ladders

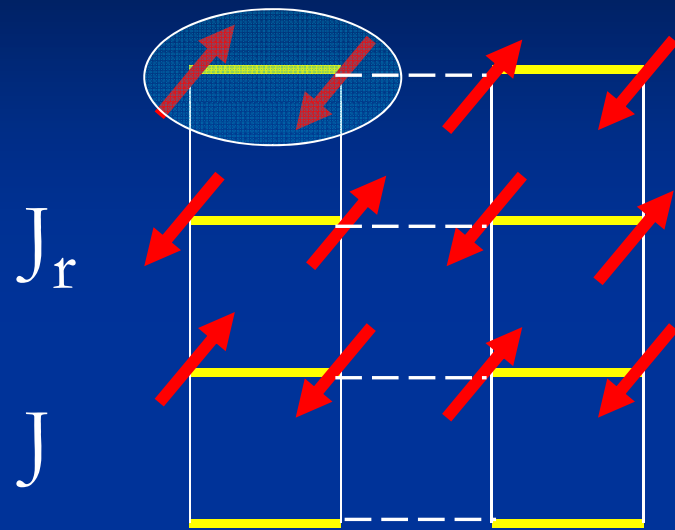

Spin Ladders

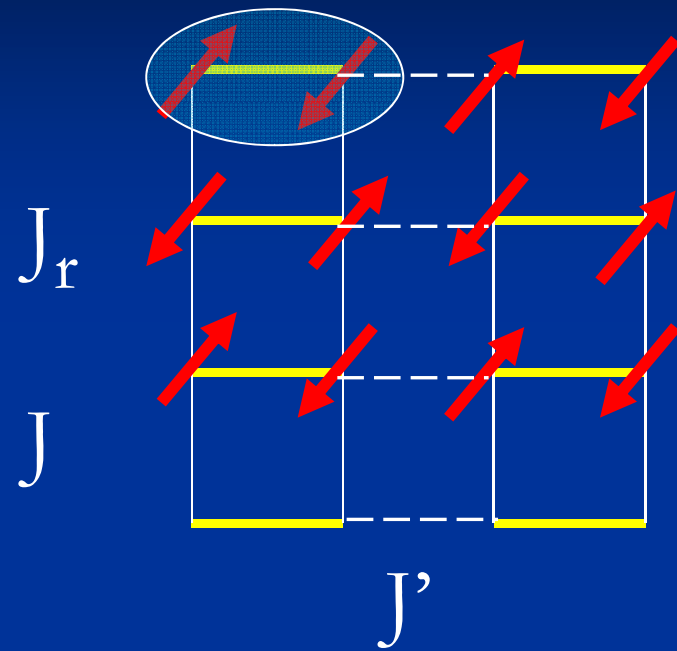

Spin Ladders

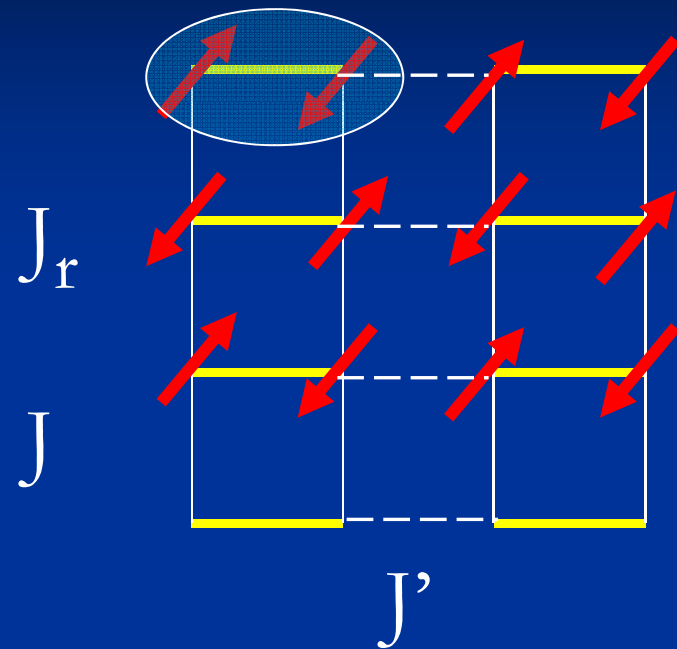

Spin Ladders

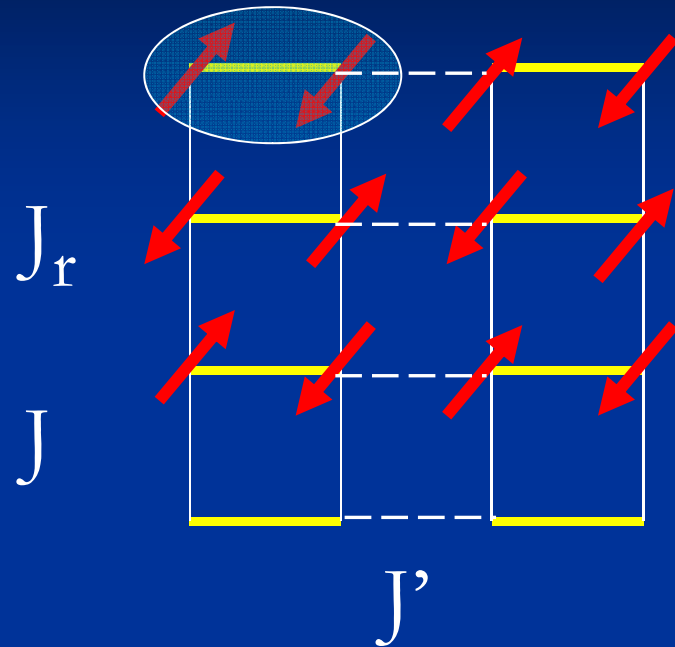

3 scales :

J_r : rungs

J : legs

J' : interladder exchange

Spin Ladders

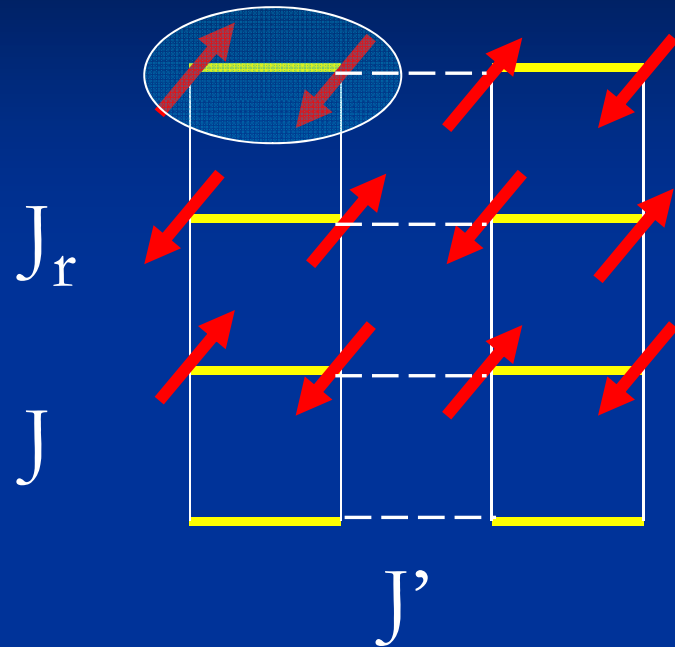

3 scales :

J_r : rungs

J : legs

J' : interladder exchange

Spin Ladders

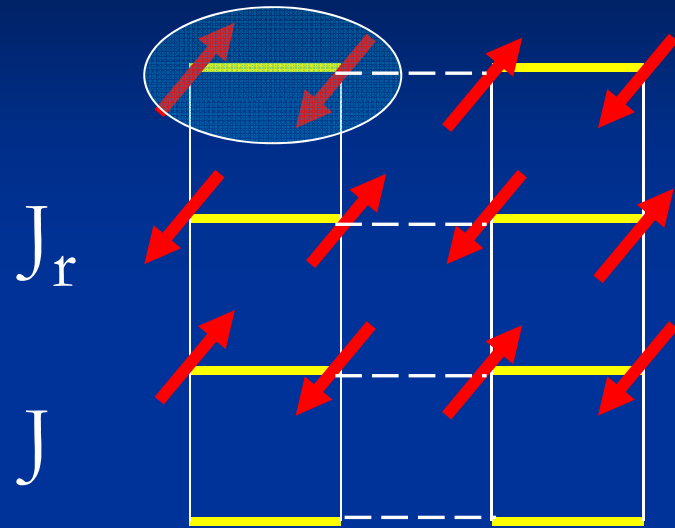

3 scales :

J_r : rungs

J : legs

J' : interladder exchange

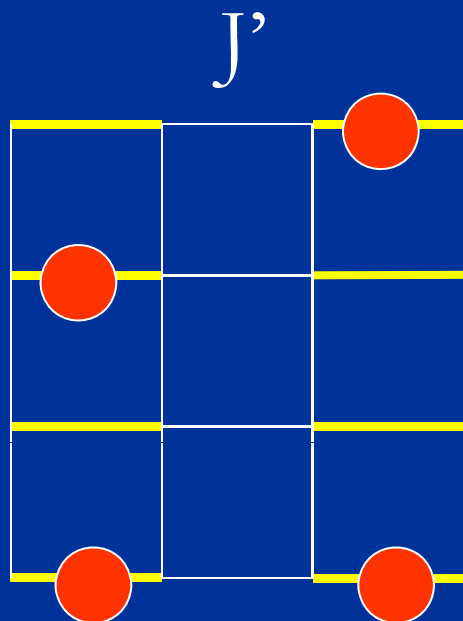

Spin Ladders

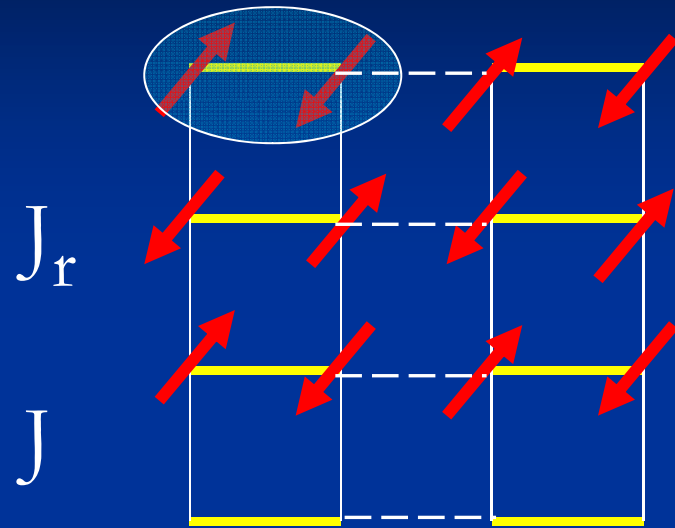

3 scales :

J_r : rungs

J : legs

J' : interladder exchange

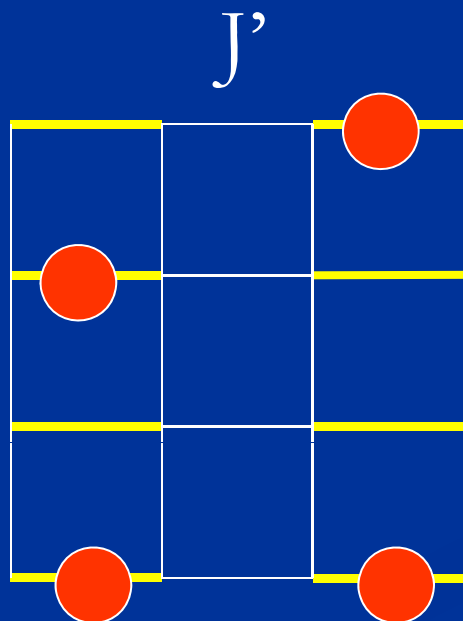

Triplons:

hard core bosons

1D : spinless fermions

Effect of magnetic field



Effect of magnetic field



Effect of magnetic field



Effect of magnetic field



Effect of magnetic field



Effect of magnetic field

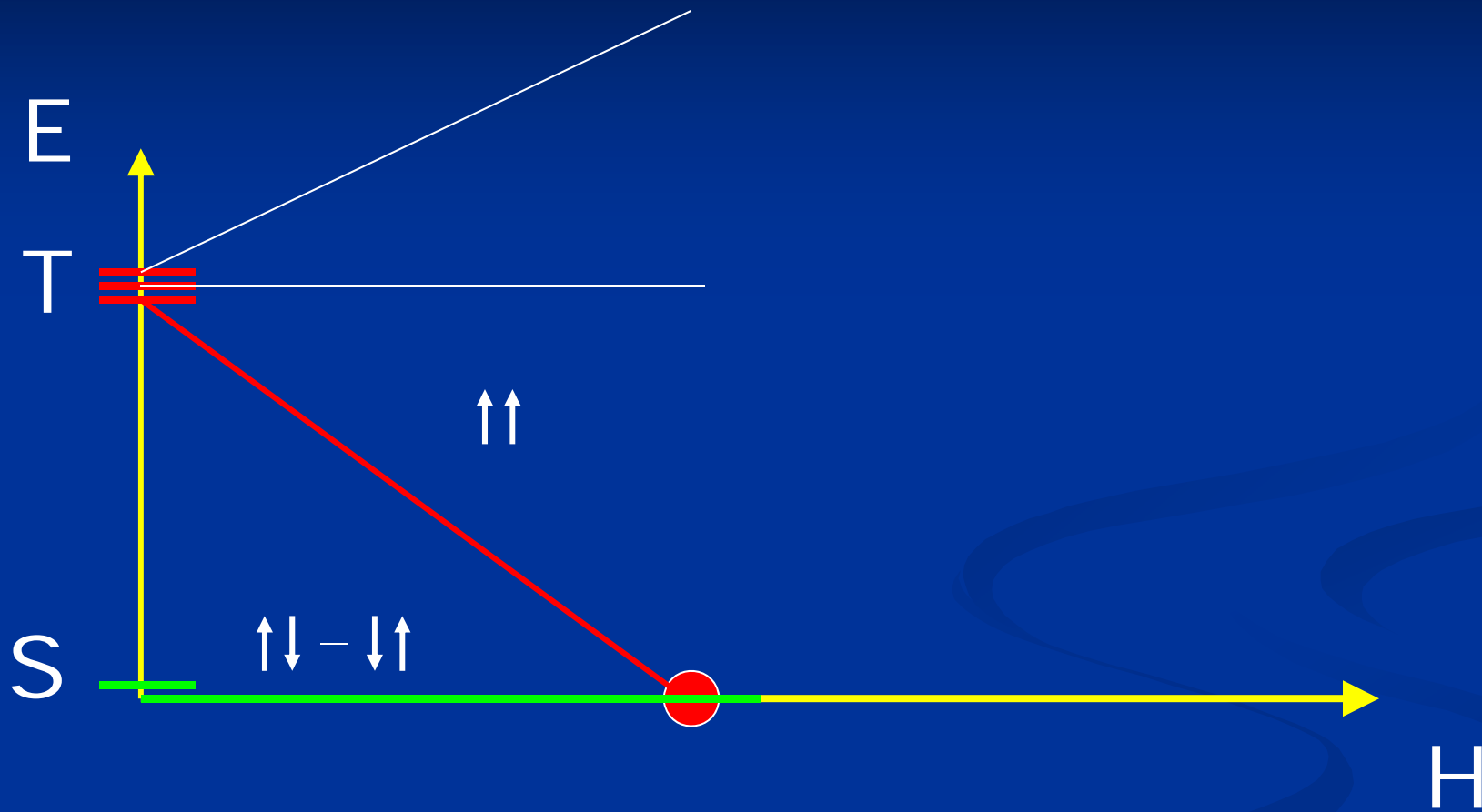

Effect of magnetic field

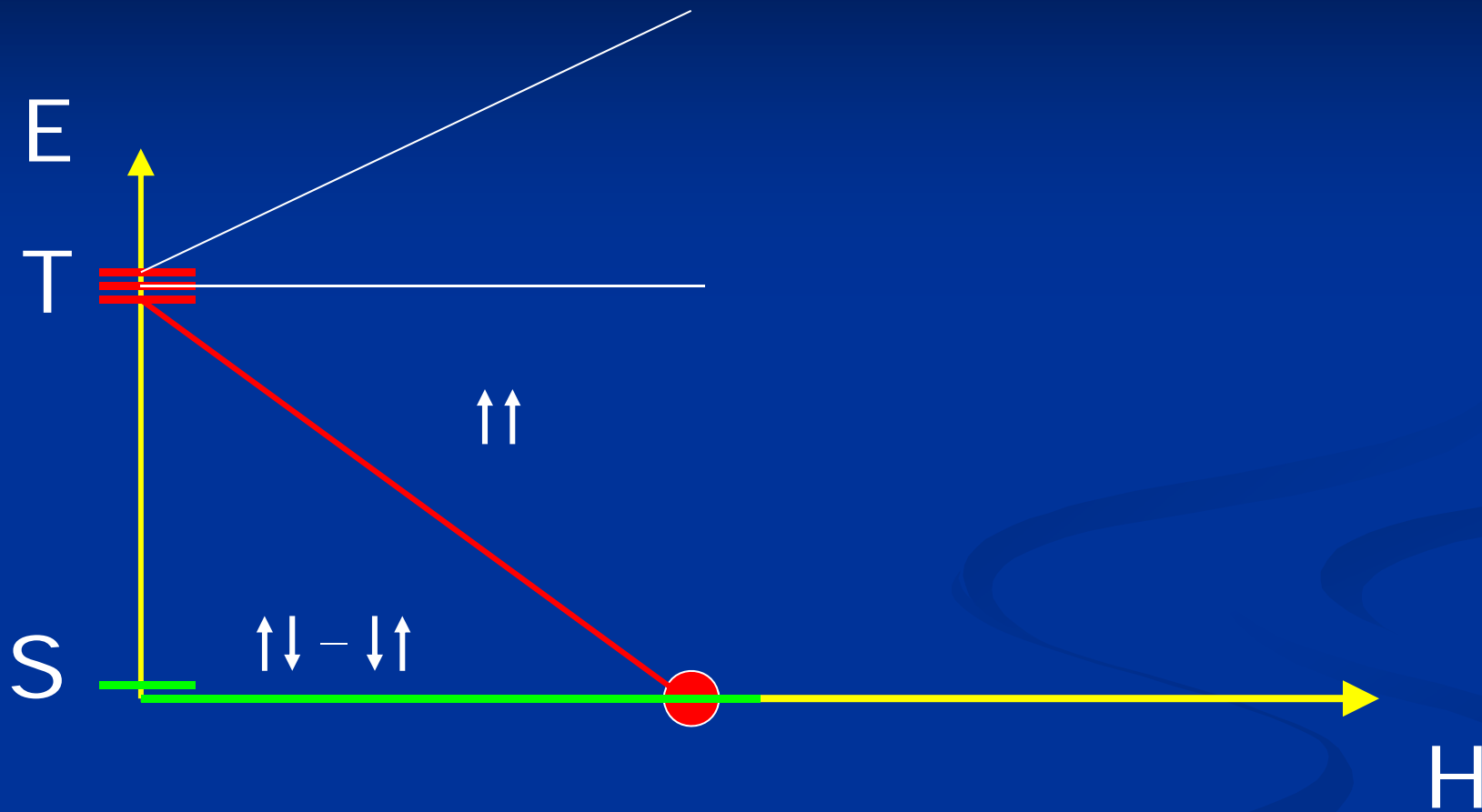

Effect of magnetic field

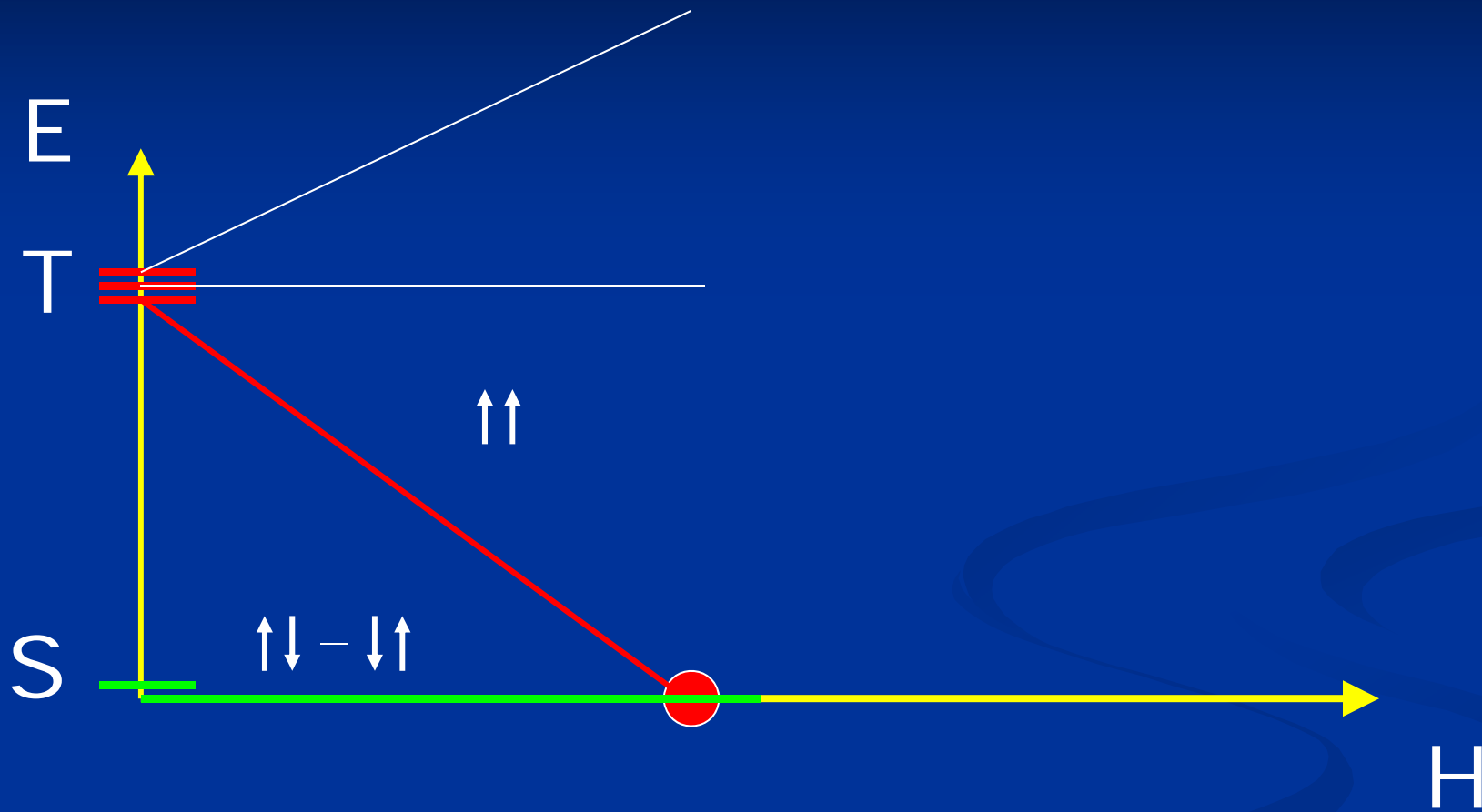

Effect of magnetic field

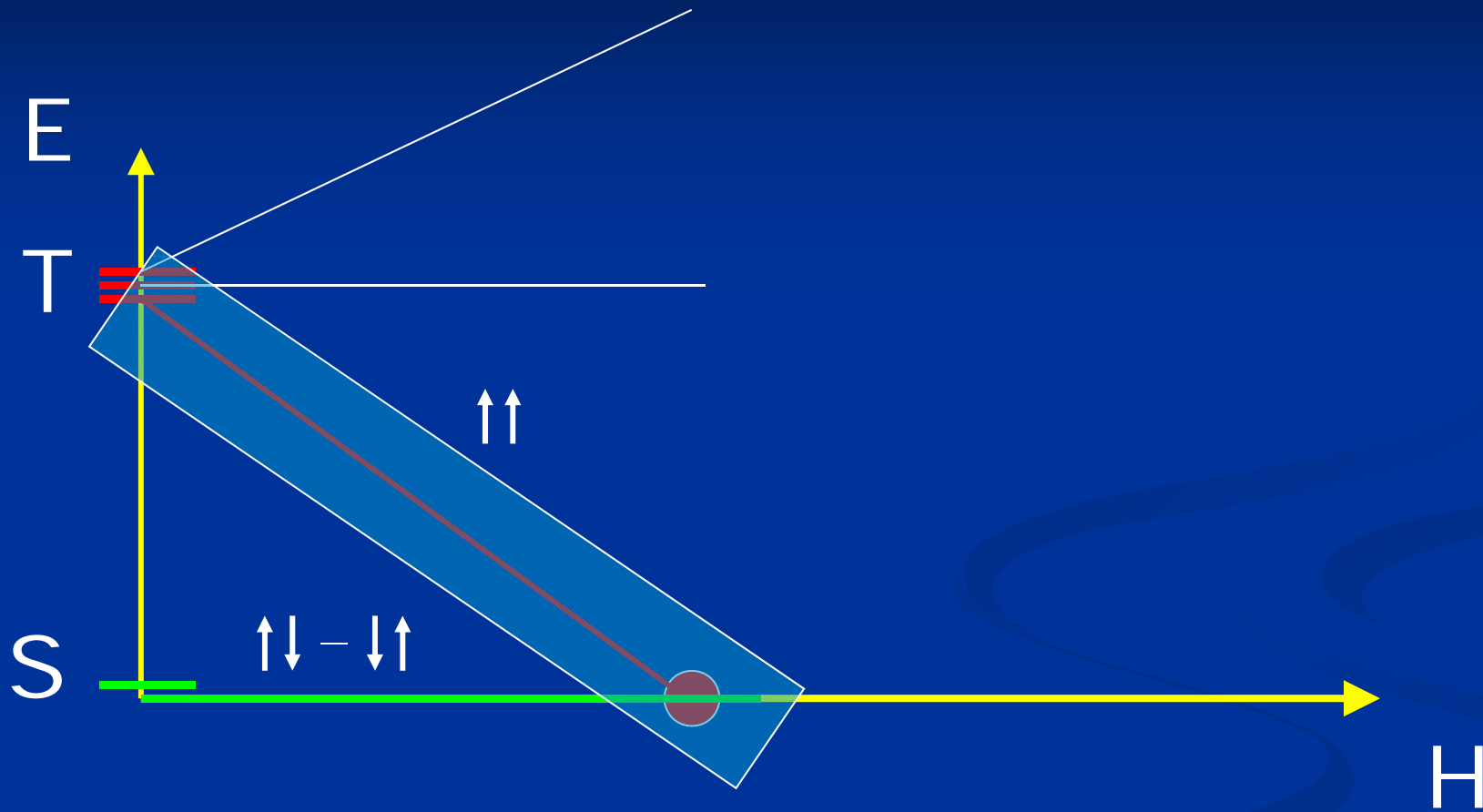

Magnetic field: like a chemical potential (hc_1 , hc_2)

m



Gapped



h



m

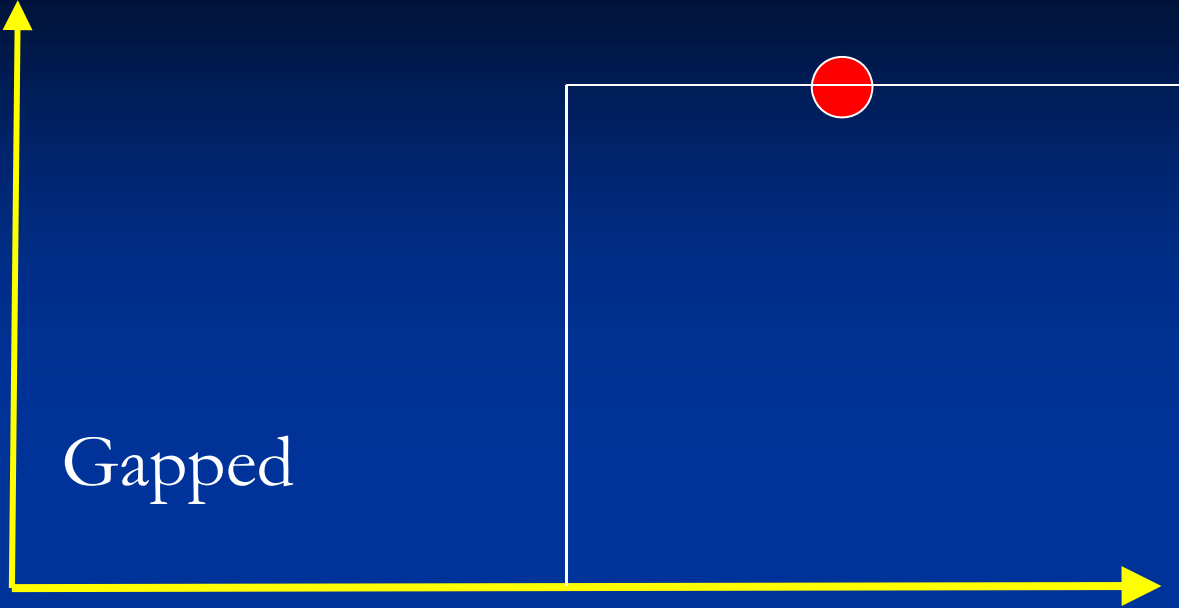

Gapped

h

m

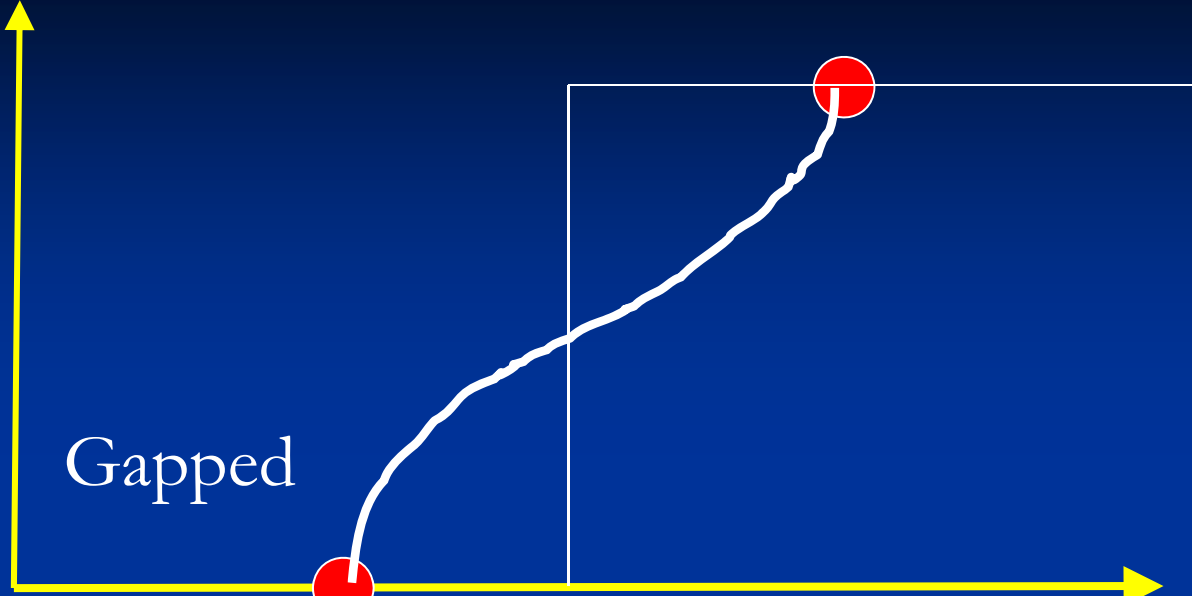

Gapped

h

m

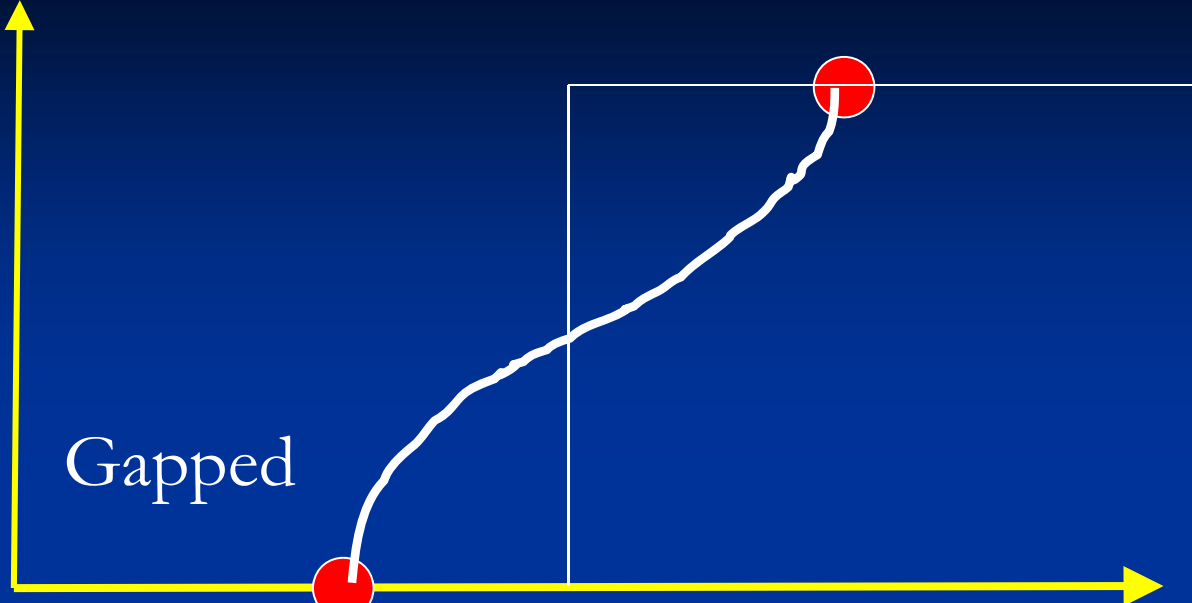

Gapped

h_{c1}

h

m

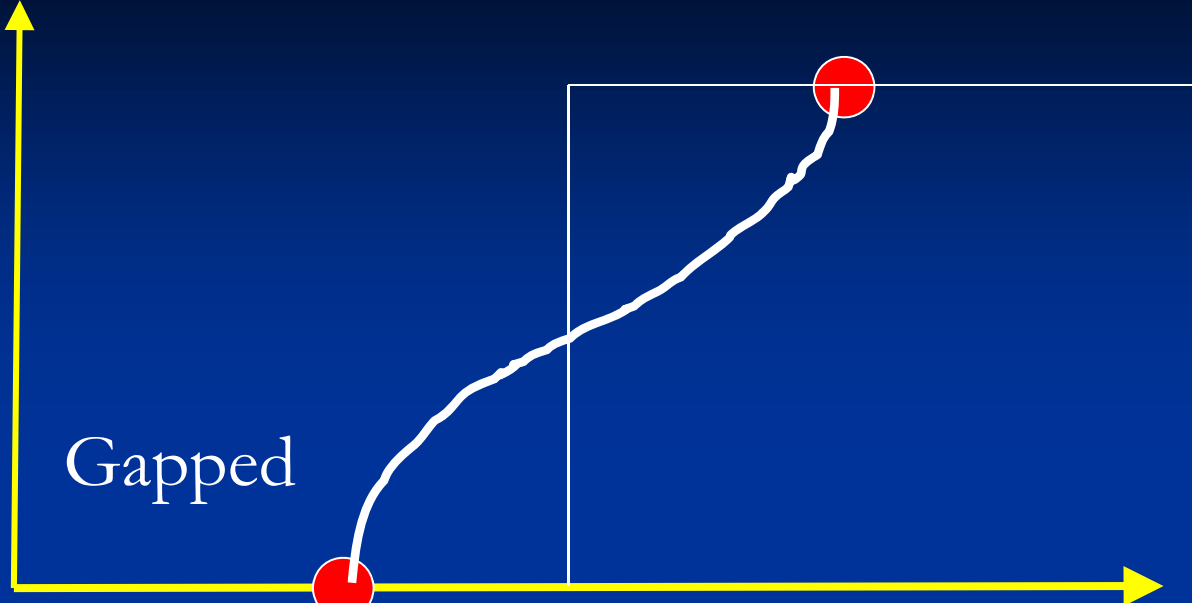

Gapped

h_{c1}

h_{c2}

h

m

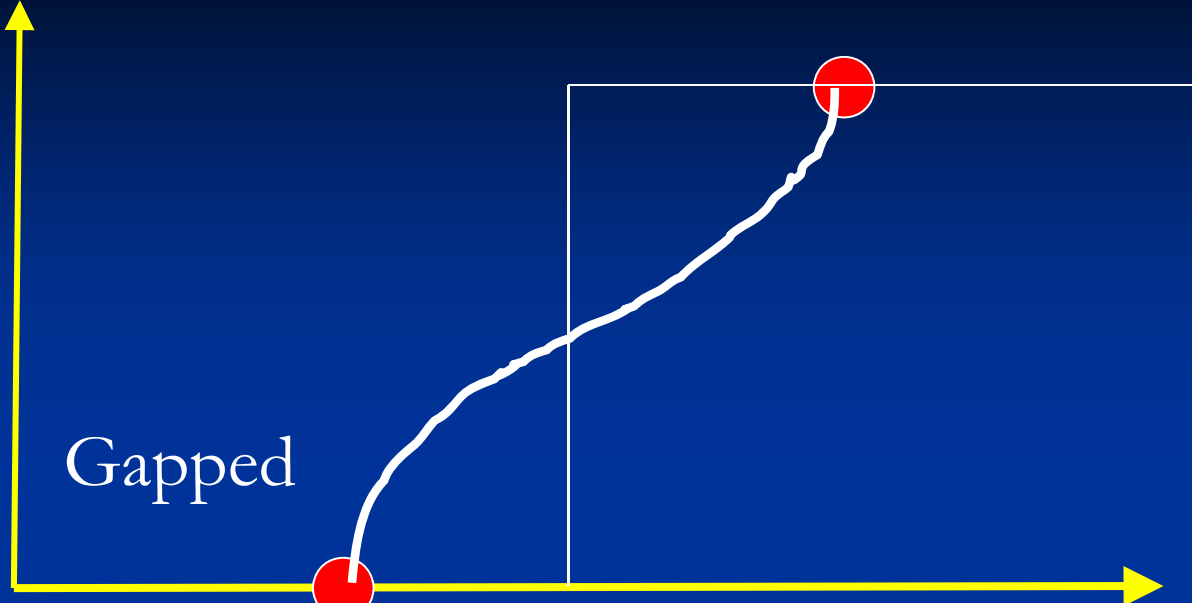

Gapped

h_{c1}

h_{c2}

h

m

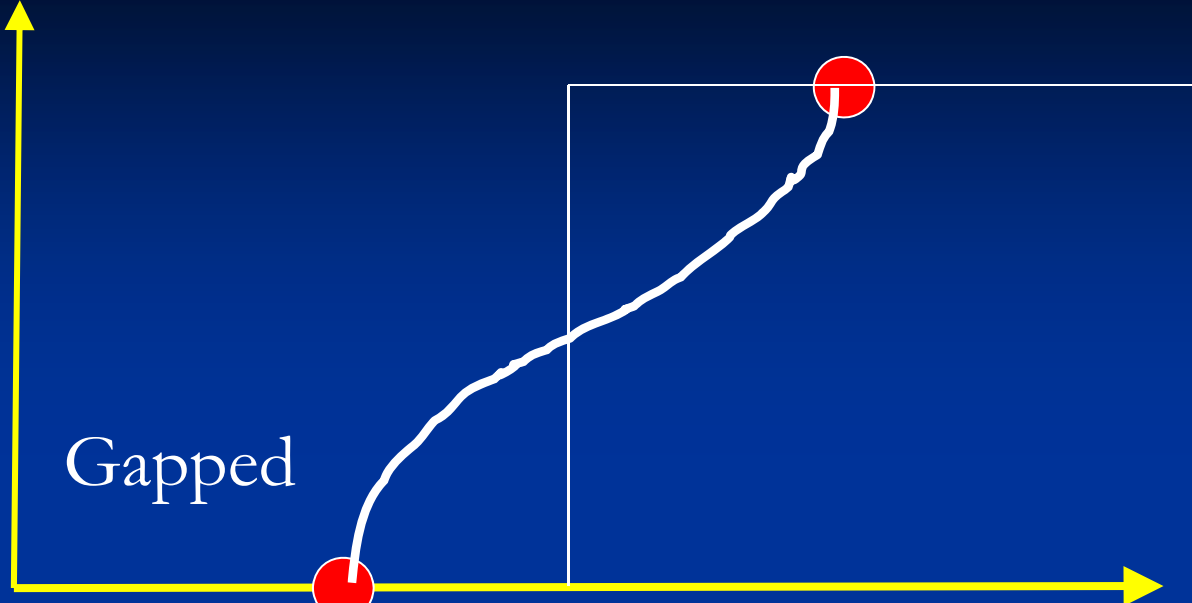

Gapped

h_{c1}

h_{c2}

h

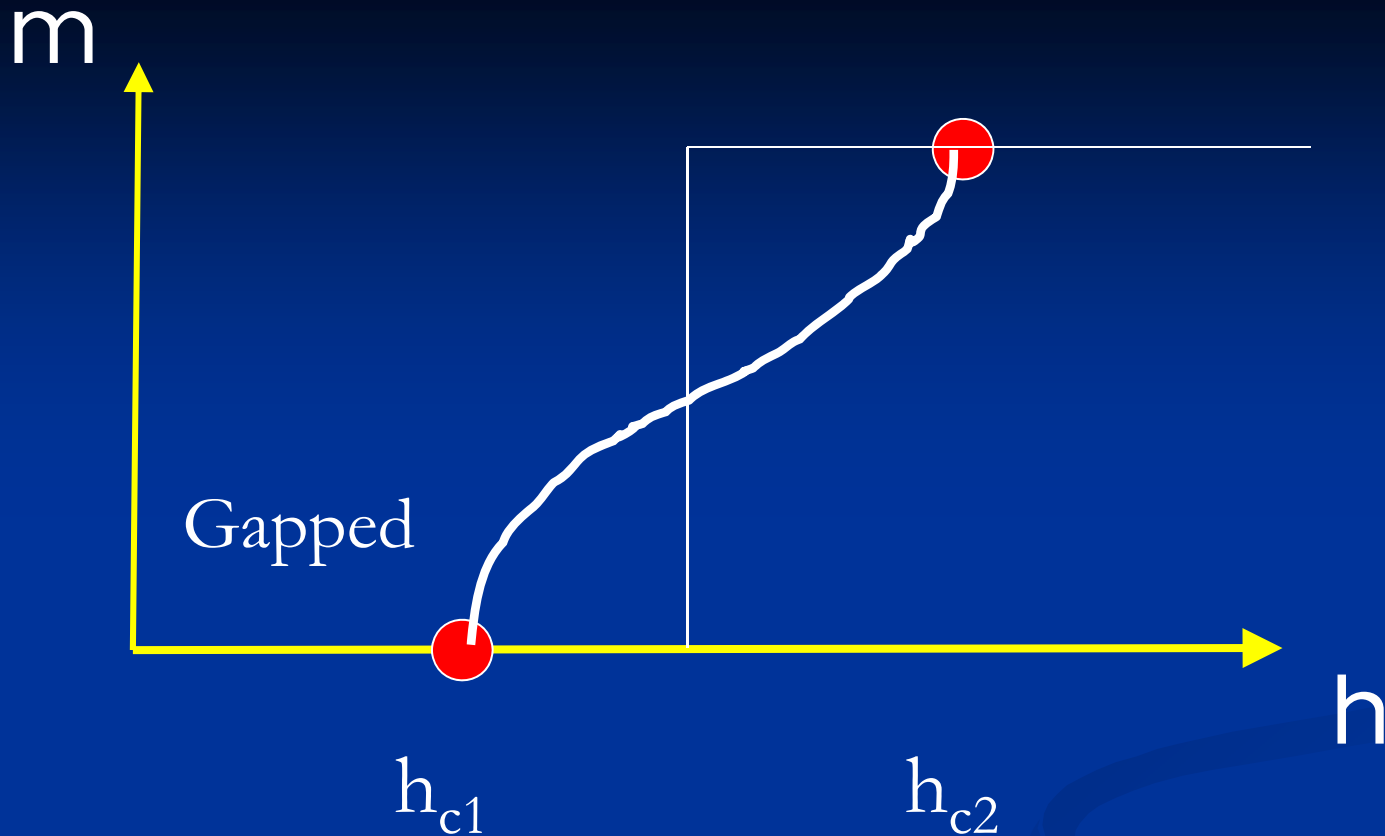

$$h_{c1} \sim J_r ; h_{c2} \sim J_r + J$$

A way to study interacting spinless fermions !

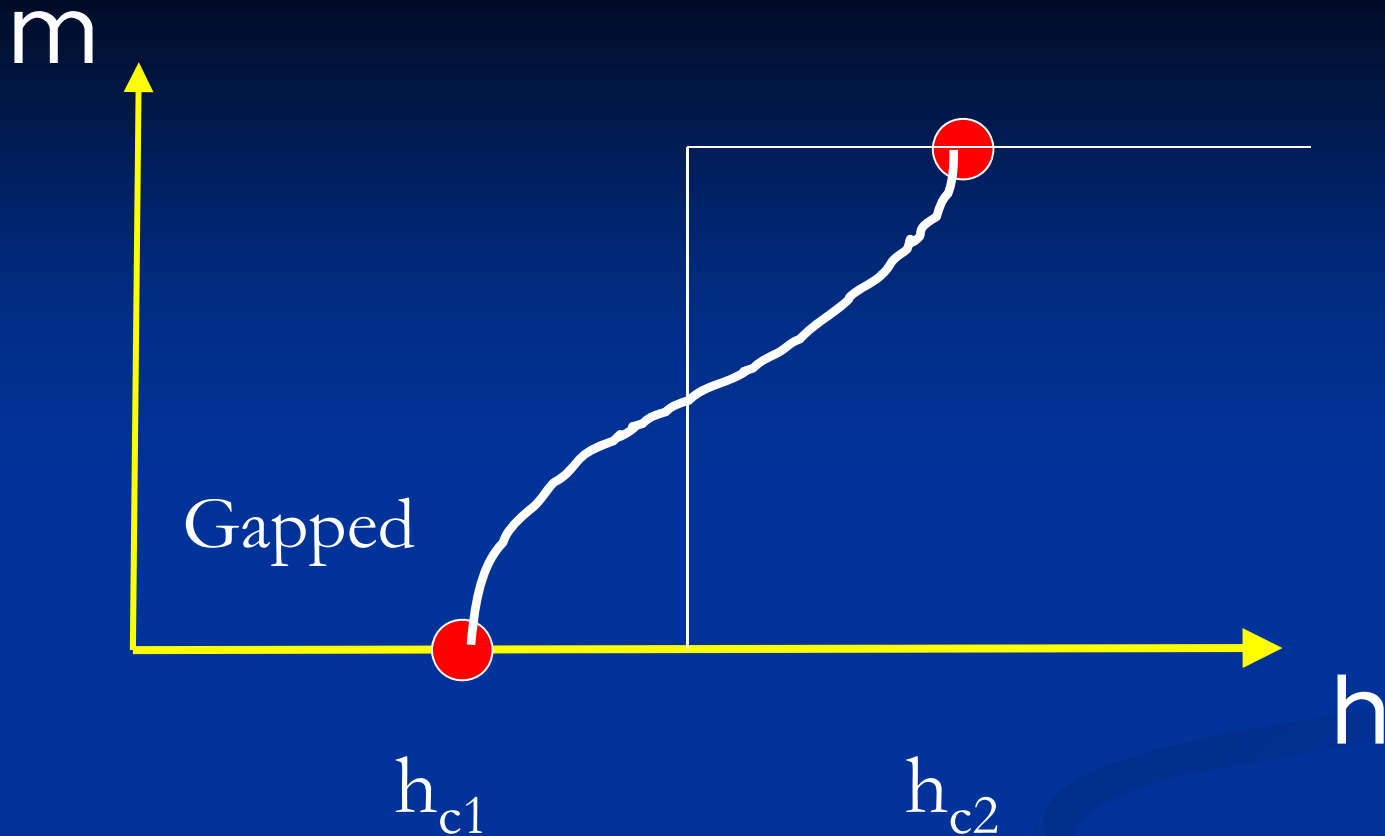

$$h_{c1} \sim J_r ; h_{c2} \sim J_r + J$$

A way to study interacting spinless fermions !

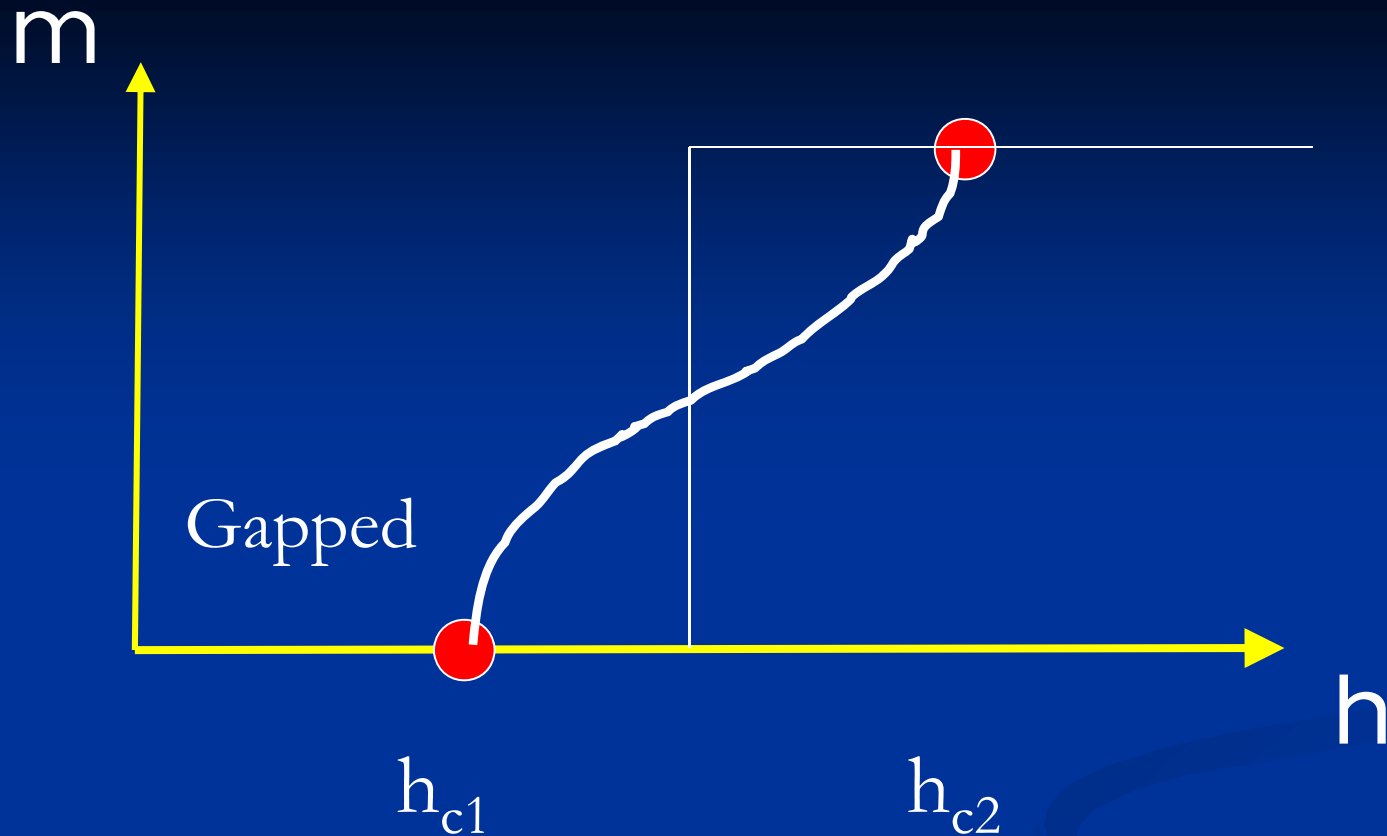

$$h_{c1} \sim J_r ; h_{c2} \sim J_r + J$$

A way to study interacting spinless fermions !

All microscopic parameters are known !

Expected phase diagram

S. Sachdev , T. Senthil, R. Shankar PRB 50 258 (94); R. Chitra, TG PRB 55 5816 (97); TG,
A.M. Tsvelik PRB 59 11398 (99)



Expected phase diagram

S. Sachdev , T. Senthil, R. Shankar PRB 50 258 (94); R. Chitra, TG PRB 55 5816 (97); TG,
A.M. Tsvelik PRB 59 11398 (99)

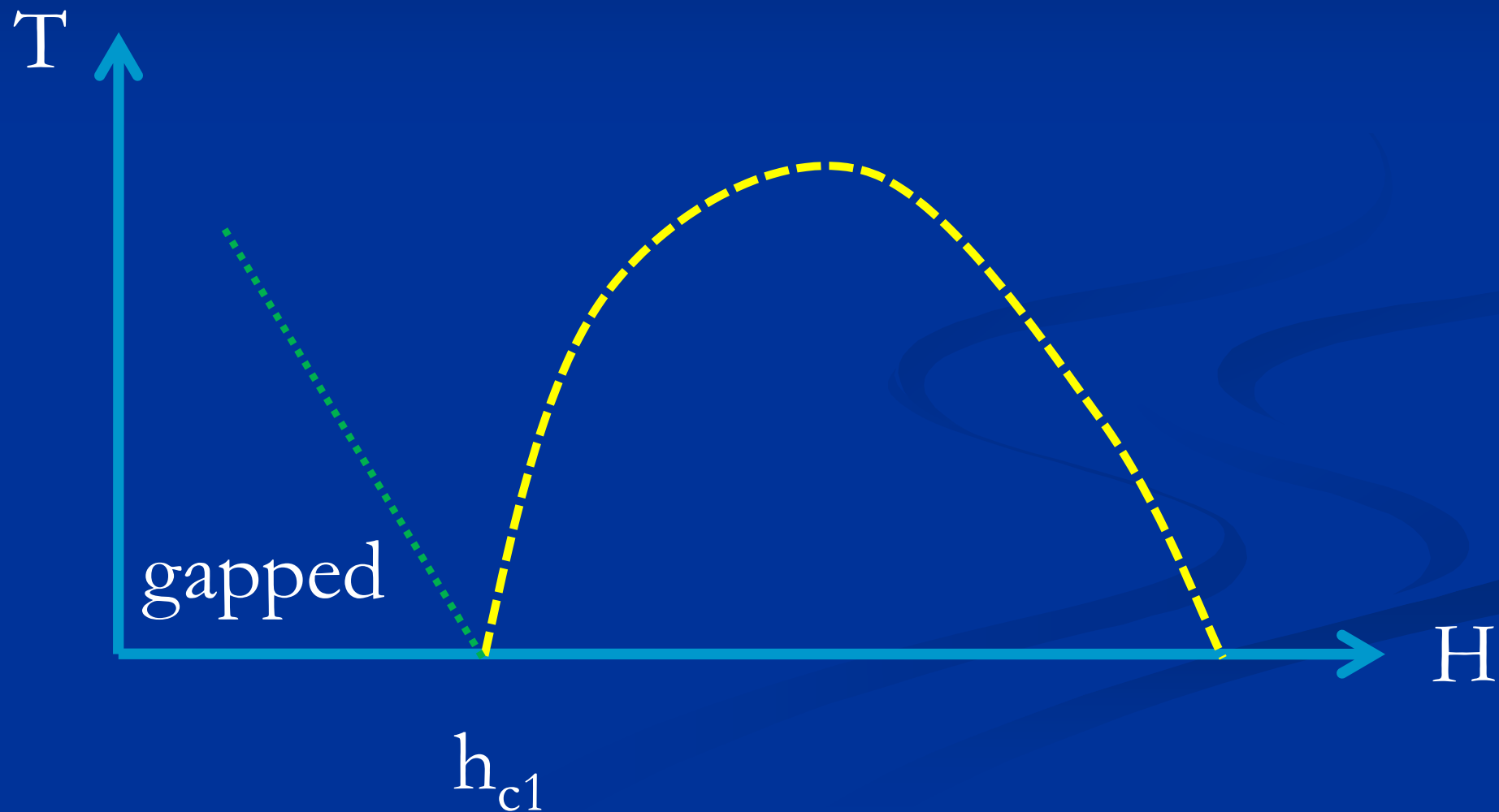

Expected phase diagram

S. Sachdev , T. Senthil, R. Shankar PRB 50 258 (94); R. Chitra, TG PRB 55 5816 (97); TG,
A.M. Tsvelik PRB 59 11398 (99)

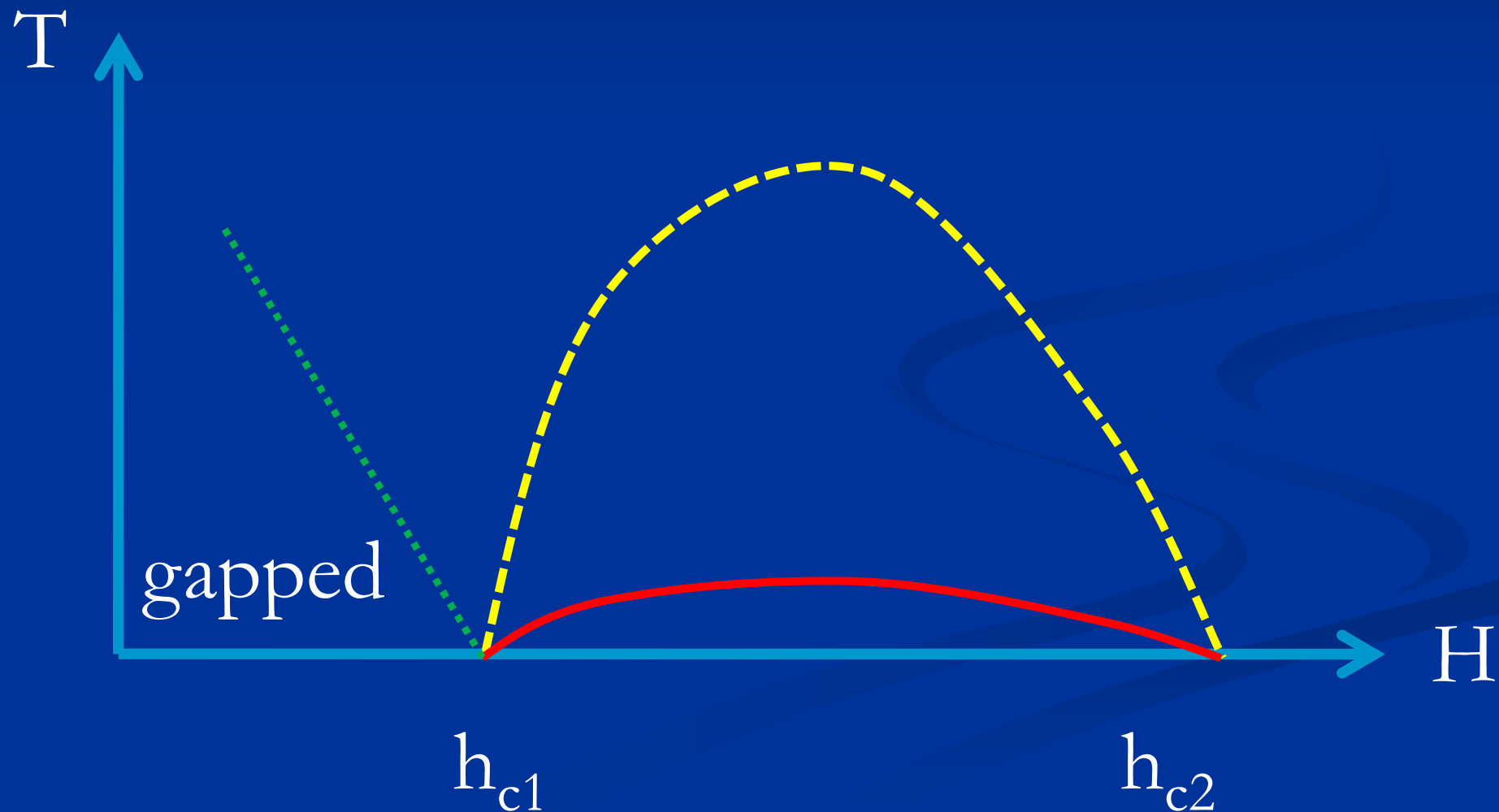

Expected phase diagram

S. Sachdev , T. Senthil, R. Shankar PRB 50 258 (94); R. Chitra, TG PRB 55 5816 (97); TG,
A.M. Tsvelik PRB 59 11398 (99)

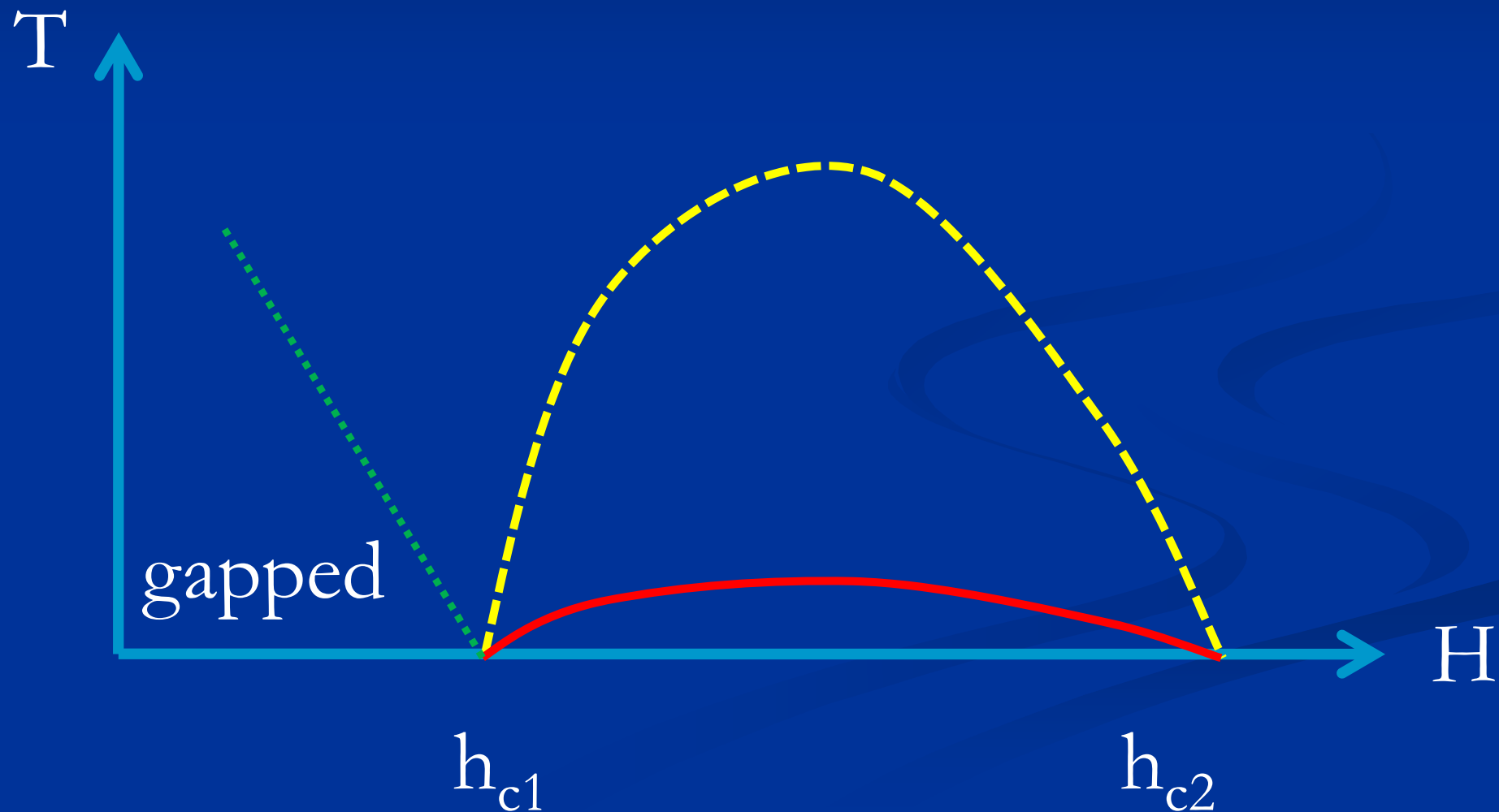

Expected phase diagram

S. Sachdev , T. Senthil, R. Shankar PRB 50 258 (94); R. Chitra, TG PRB 55 5816 (97); TG,
A.M. Tsvelik PRB 59 11398 (99)

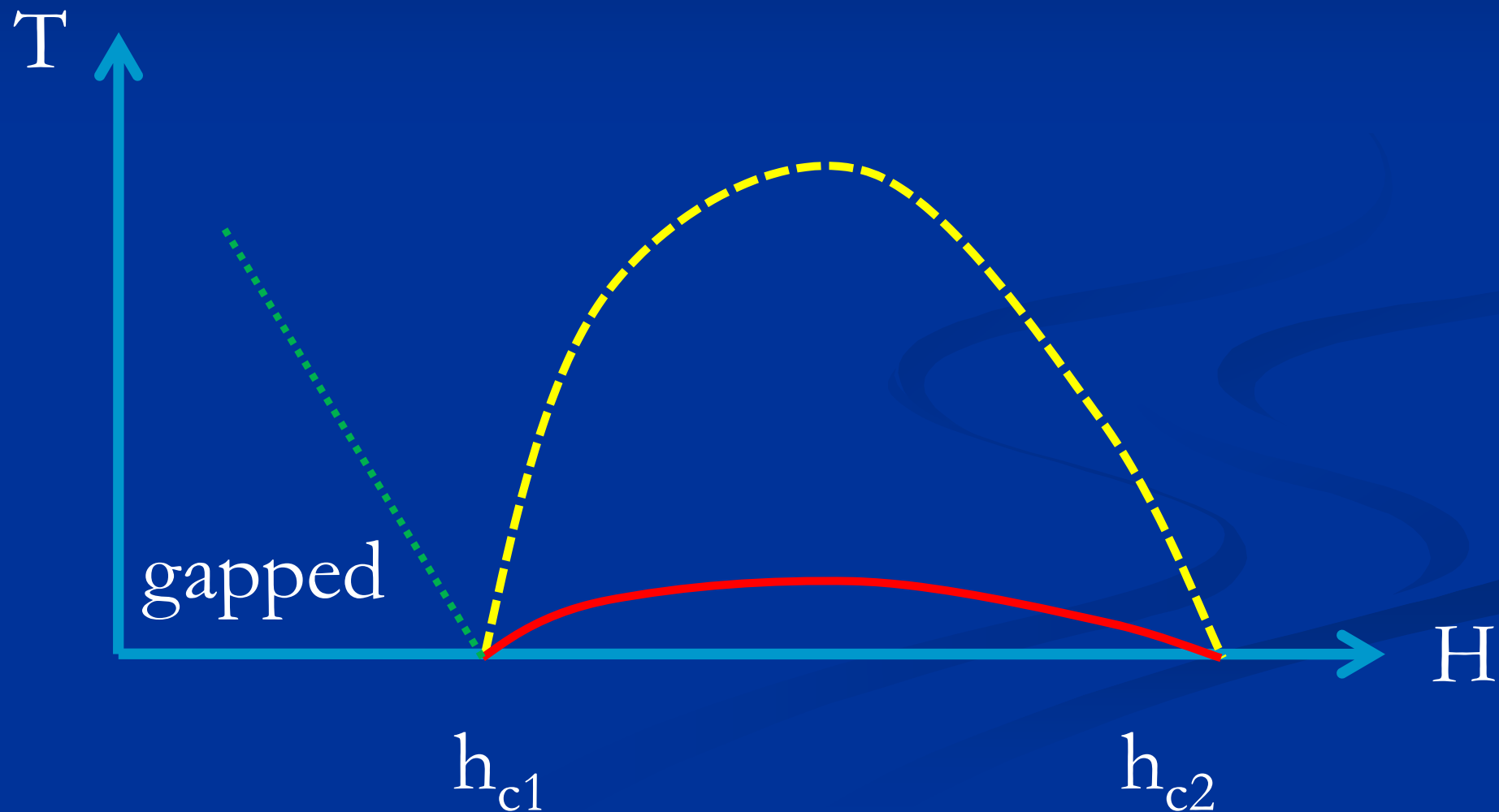

Expected phase diagram

S. Sachdev , T. Senthil, R. Shankar PRB 50 258 (94); R. Chitra, TG PRB 55 5816 (97); TG,
A.M. Tsvelik PRB 59 11398 (99)

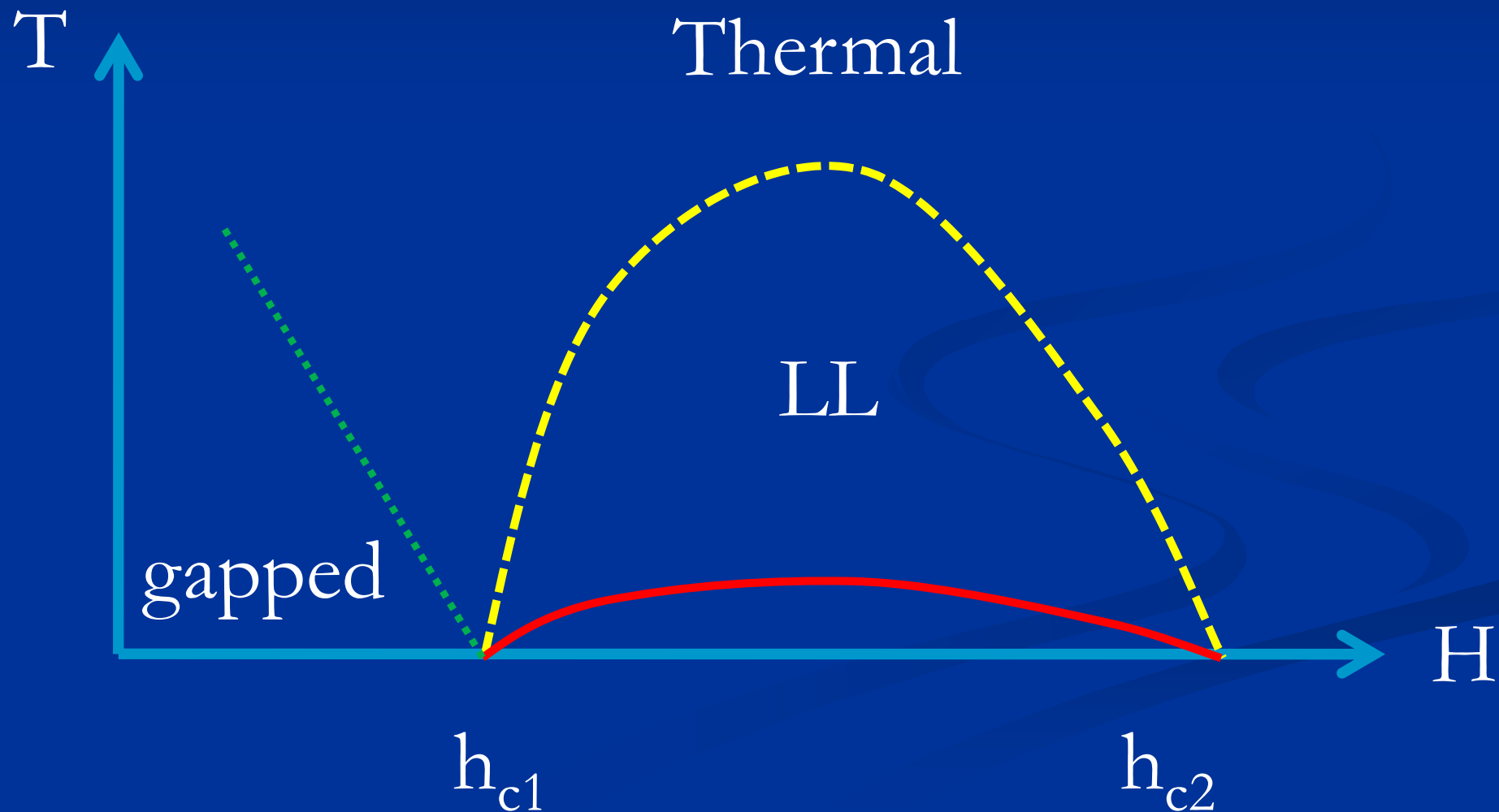

Expected phase diagram

S. Sachdev, T. Senthil, R. Shankar PRB 50 258 (94); R. Chitra, TG PRB 55 5816 (97); TG, A.M. Tsvelik PRB 59 11398 (99)

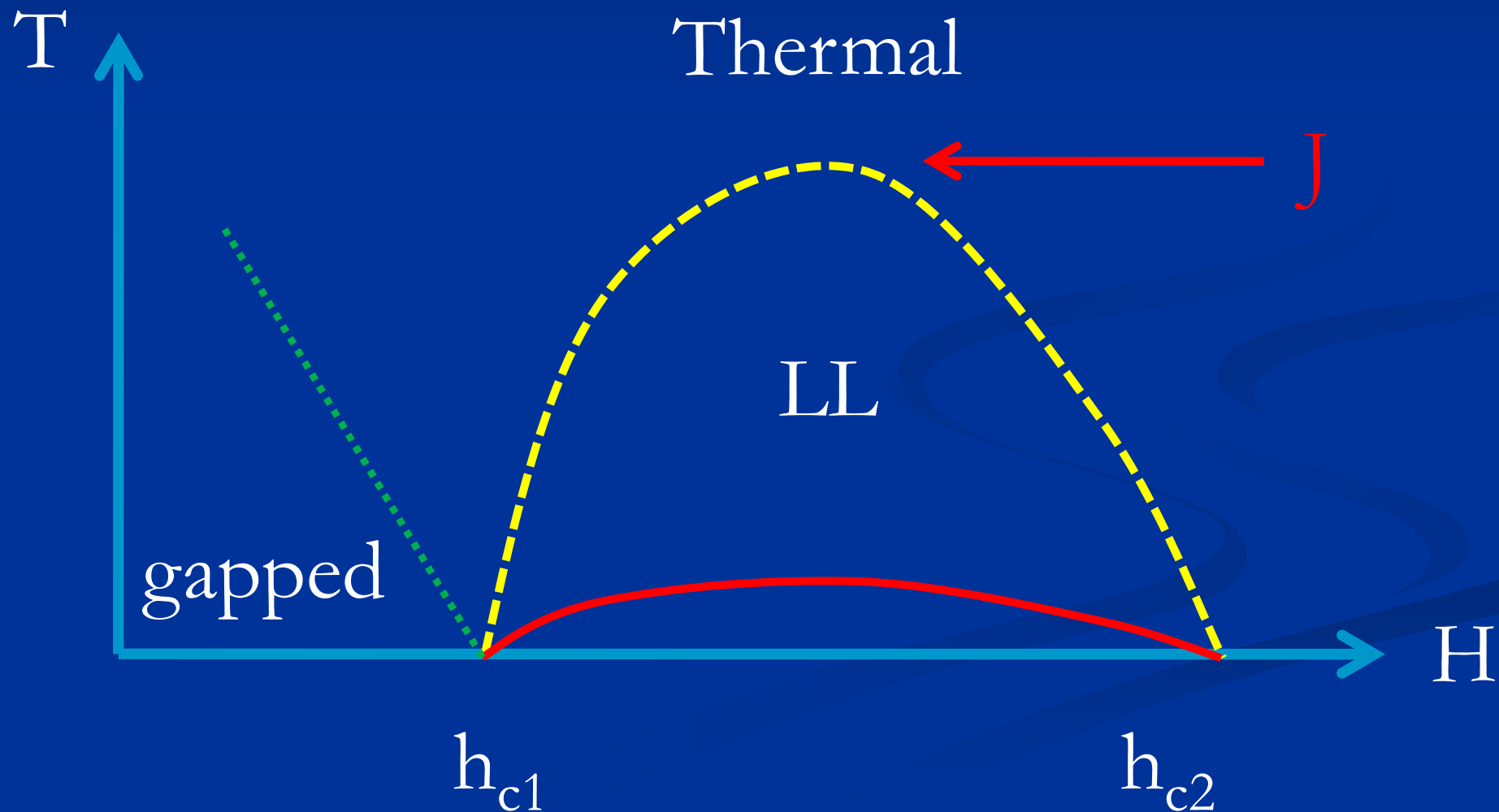

Expected phase diagram

S. Sachdev, T. Senthil, R. Shankar PRB 50 258 (94); R. Chitra, TG PRB 55 5816 (97); TG, A.M. Tsvelik PRB 59 11398 (99)

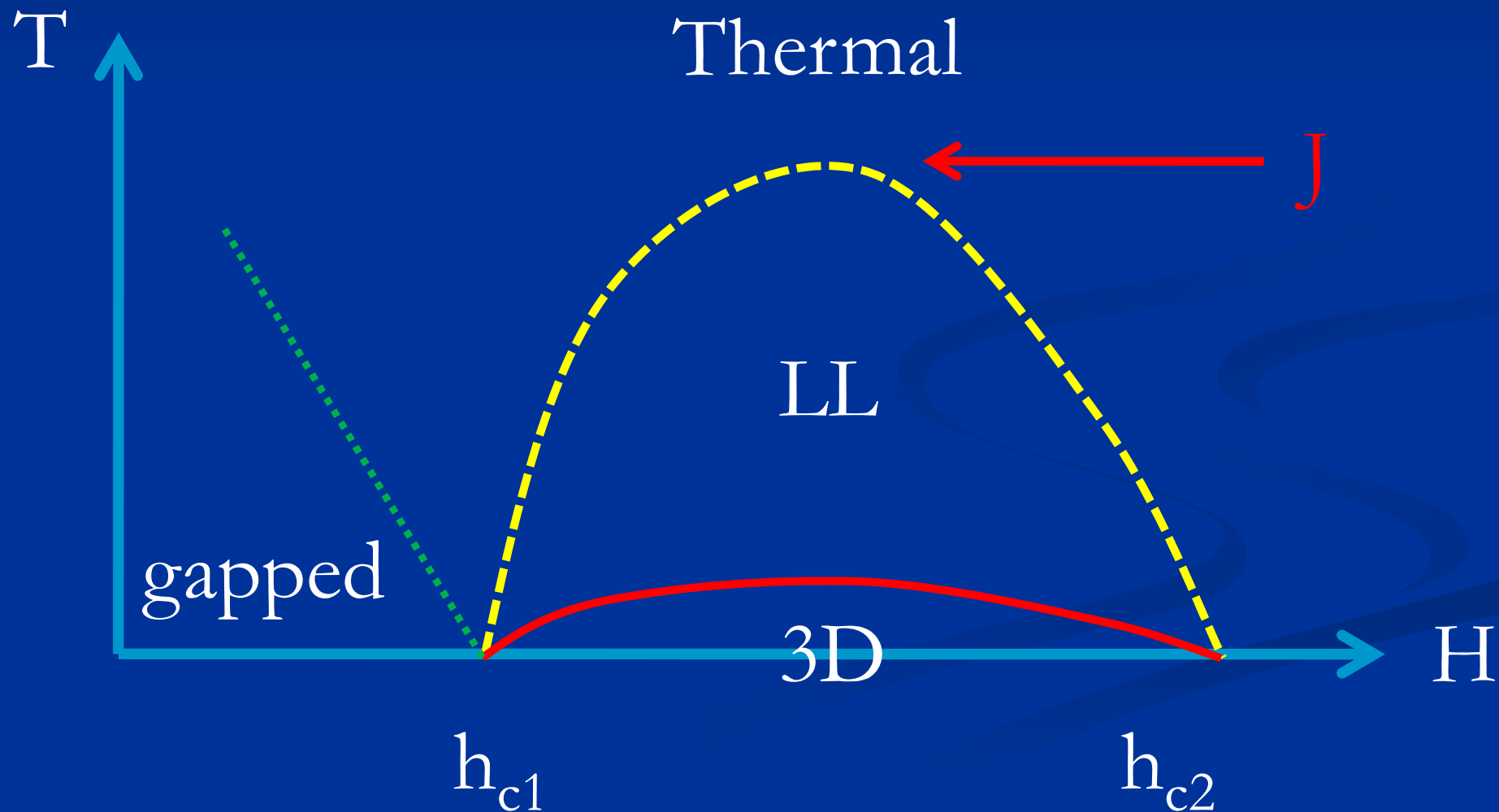

Expected phase diagram

S. Sachdev , T. Senthil, R. Shankar PRB 50 258 (94); R. Chitra, TG PRB 55 5816 (97); TG, A.M. Tsvelik PRB 59 11398 (99)

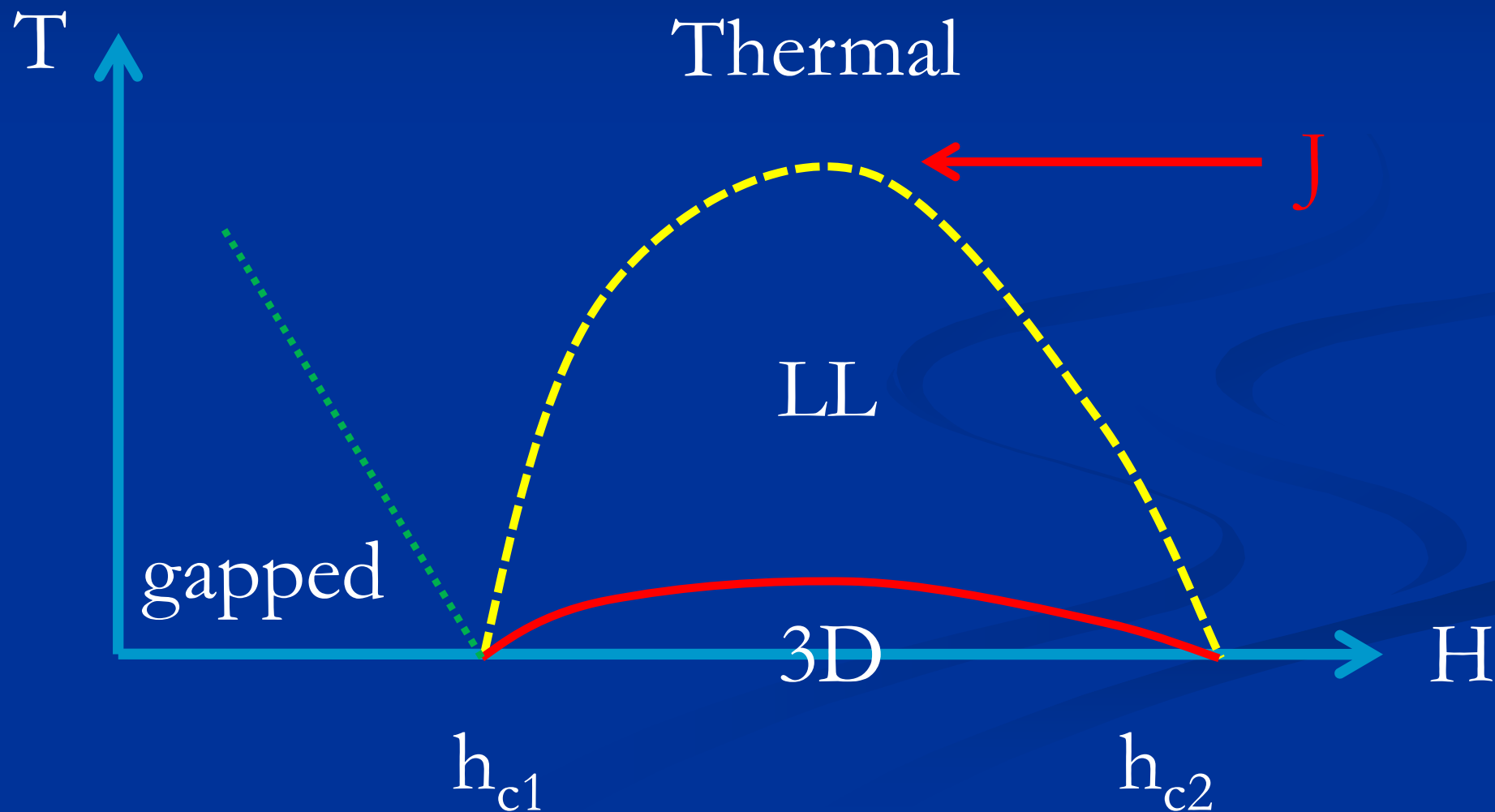

Expected phase diagram

S. Sachdev, T. Senthil, R. Shankar PRB 50 258 (94); R. Chitra, TG PRB 55 5816 (97); TG, A.M. Tsvelik PRB 59 11398 (99)

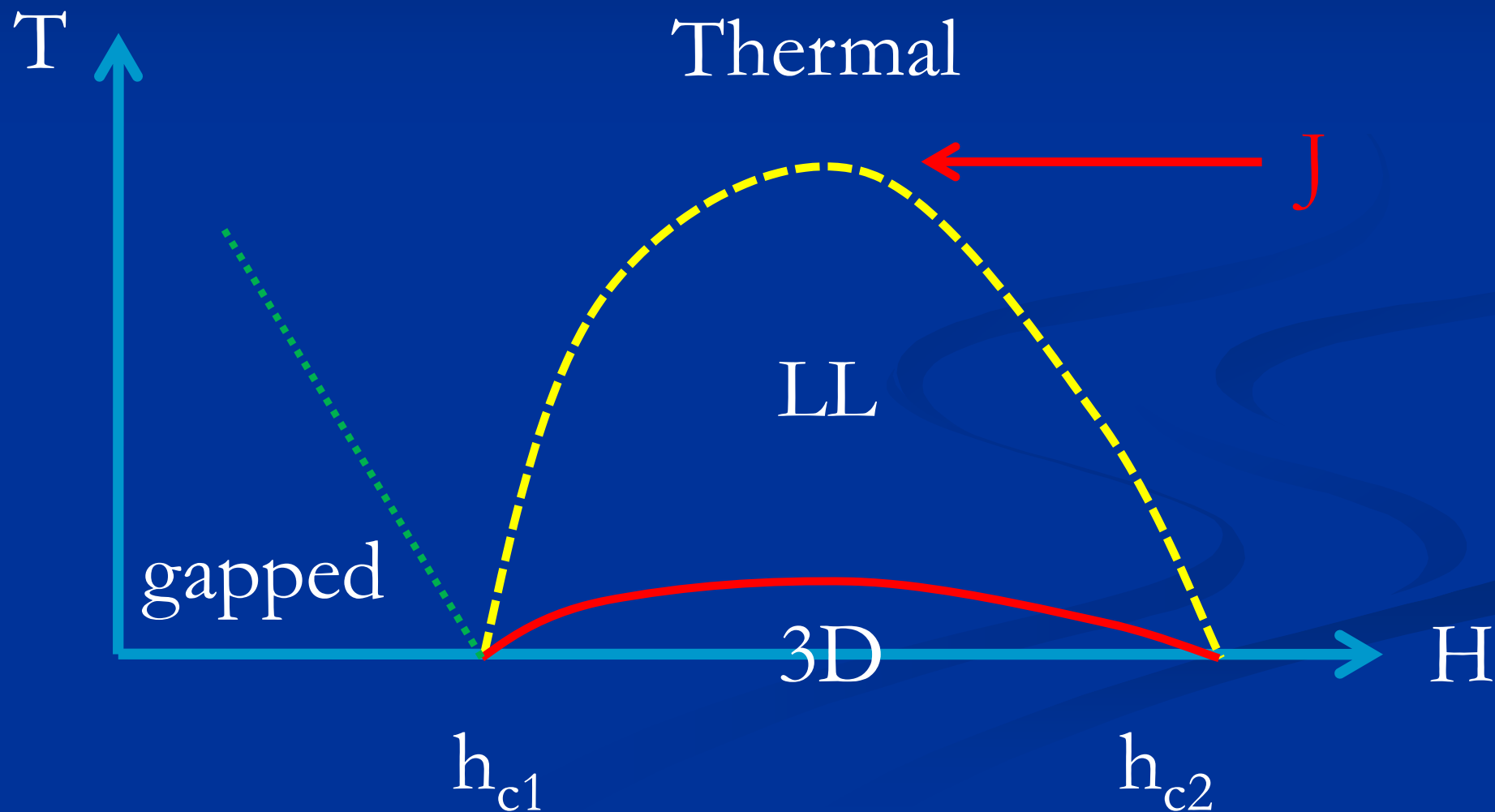

Expected phase diagram

S. Sachdev, T. Senthil, R. Shankar PRB 50 258 (94); R. Chitra, TG PRB 55 5816 (97); TG, A.M. Tsvelik PRB 59 11398 (99)

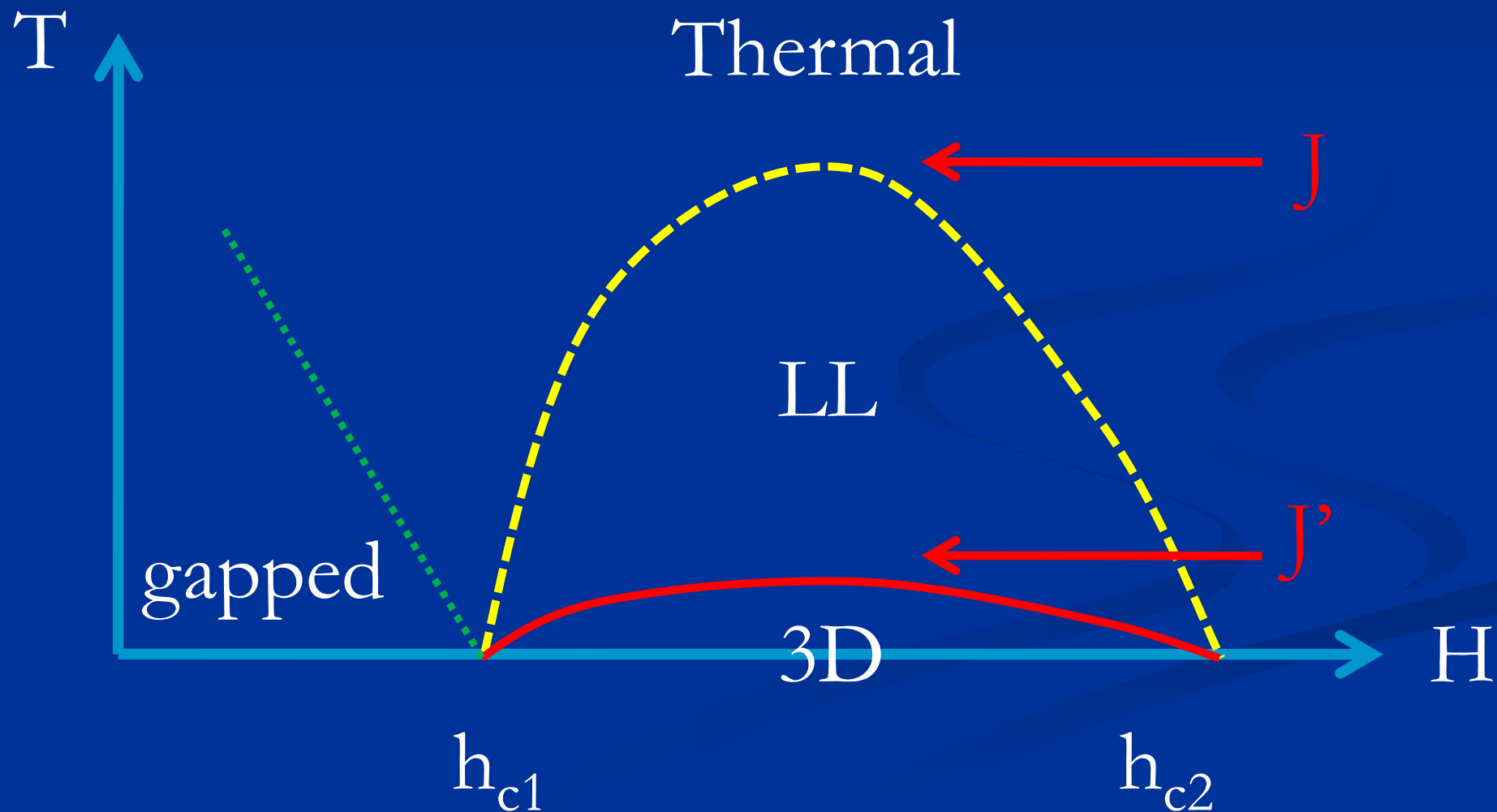

Expected phase diagram

S. Sachdev, T. Senthil, R. Shankar PRB 50 258 (94); R. Chitra, TG PRB 55 5816 (97); TG, A.M. Tsvelik PRB 59 11398 (99)

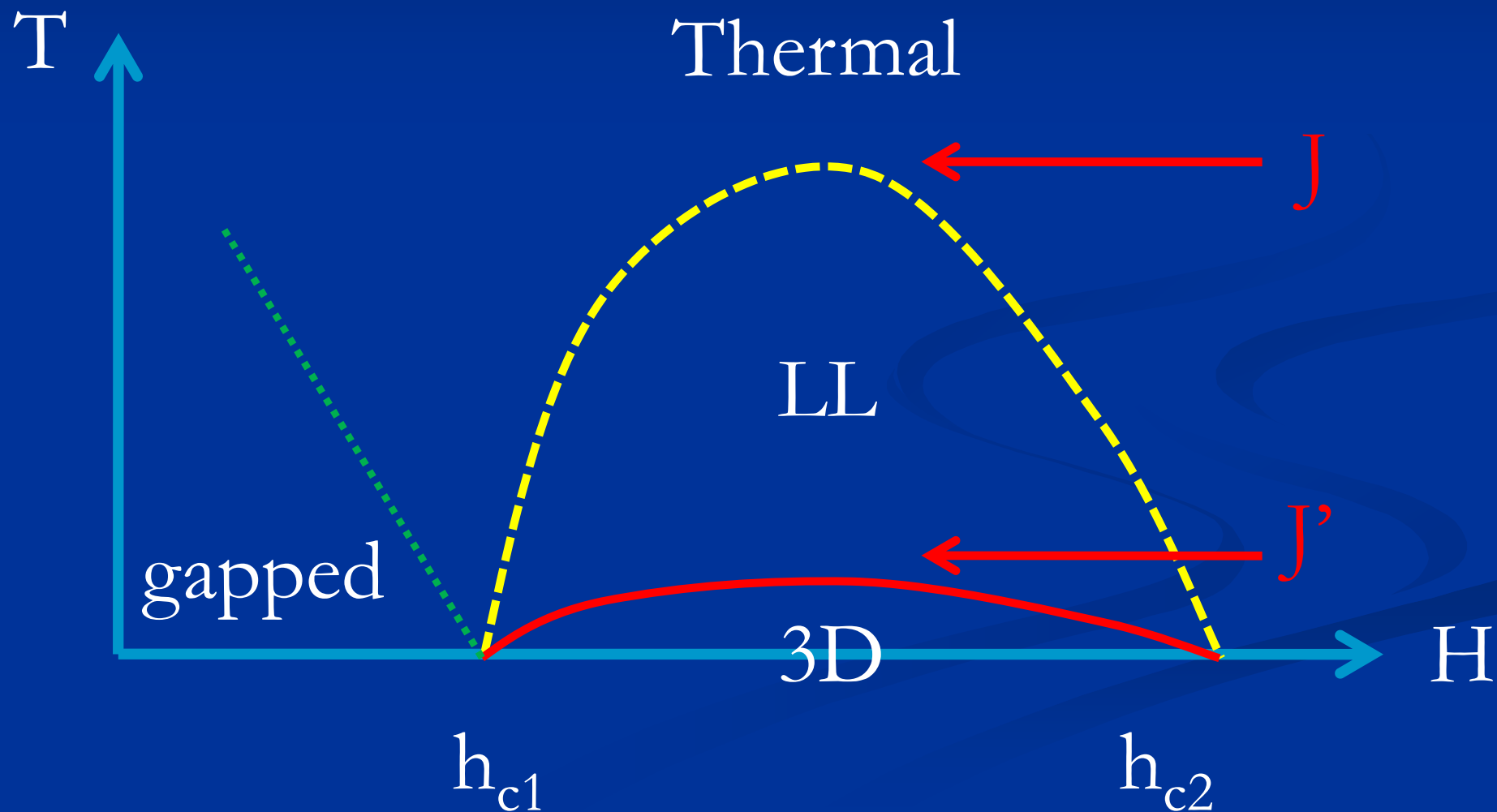

How to compute

How to compute

- Analytical calculations (Luttinger liquid + BA)

How to compute

- Analytical calculations (Luttinger liquid + BA)
- Numerical calculations (DMRG)

How to compute

- Analytical calculations (Luttinger liquid + BA)
- Numerical calculations (DMRG)



How to compute

- Analytical calculations (Luttinger liquid + BA)
- Numerical calculations (DMRG)



S. White

Finite temperature DMRG

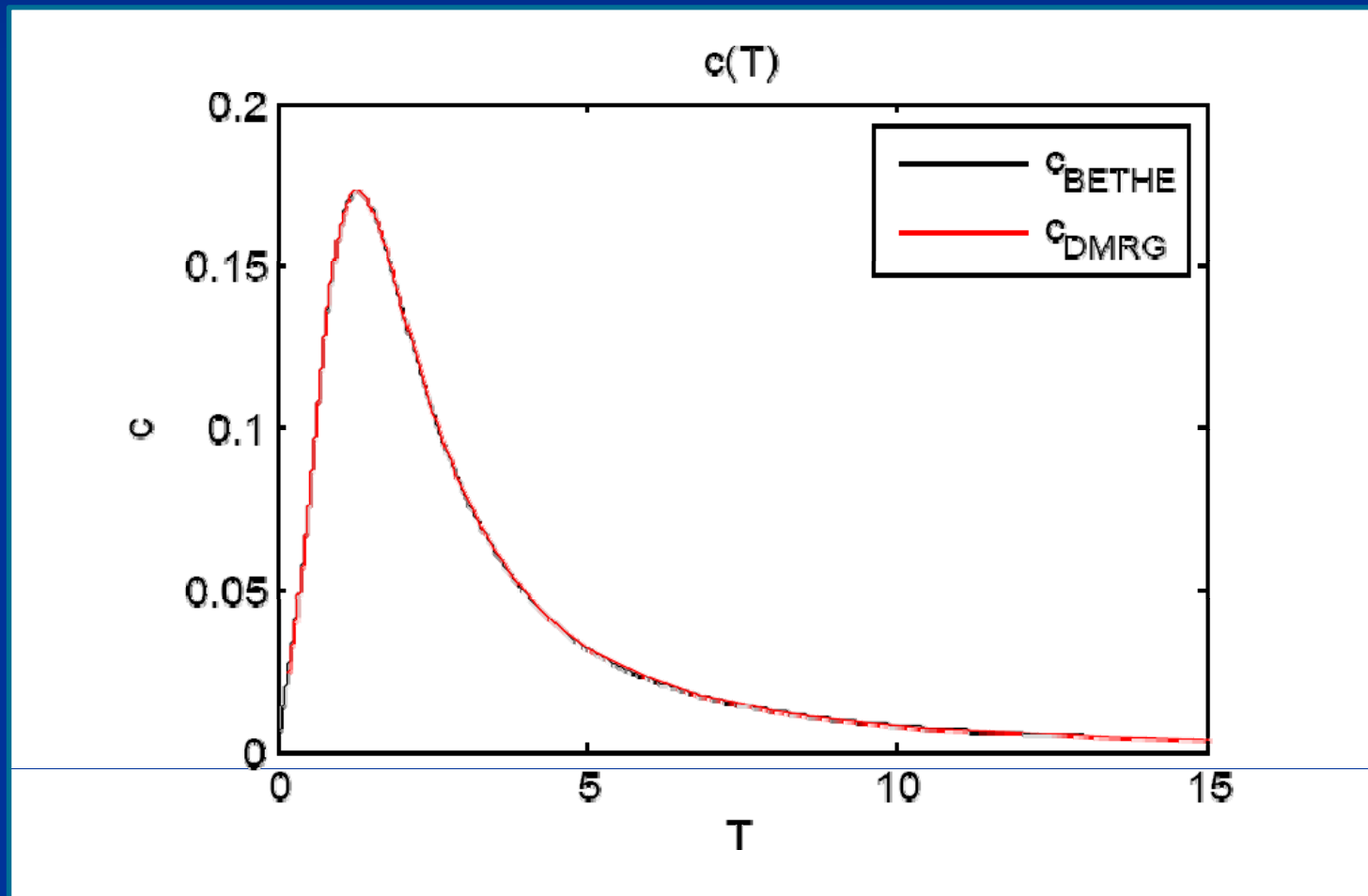

Finite temperature DMRG

Specific heat of spin chain

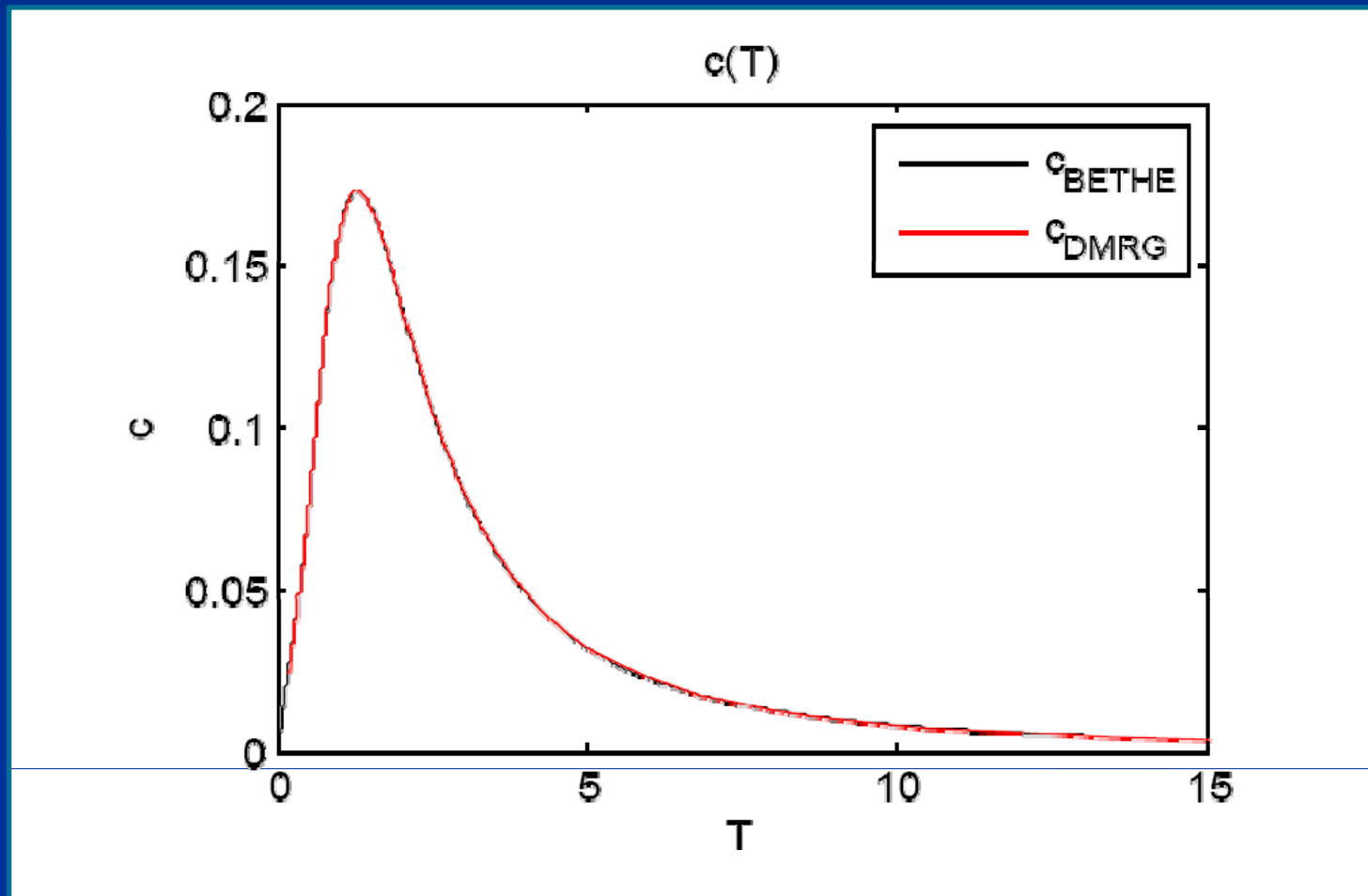

Magnetization



Magnetization

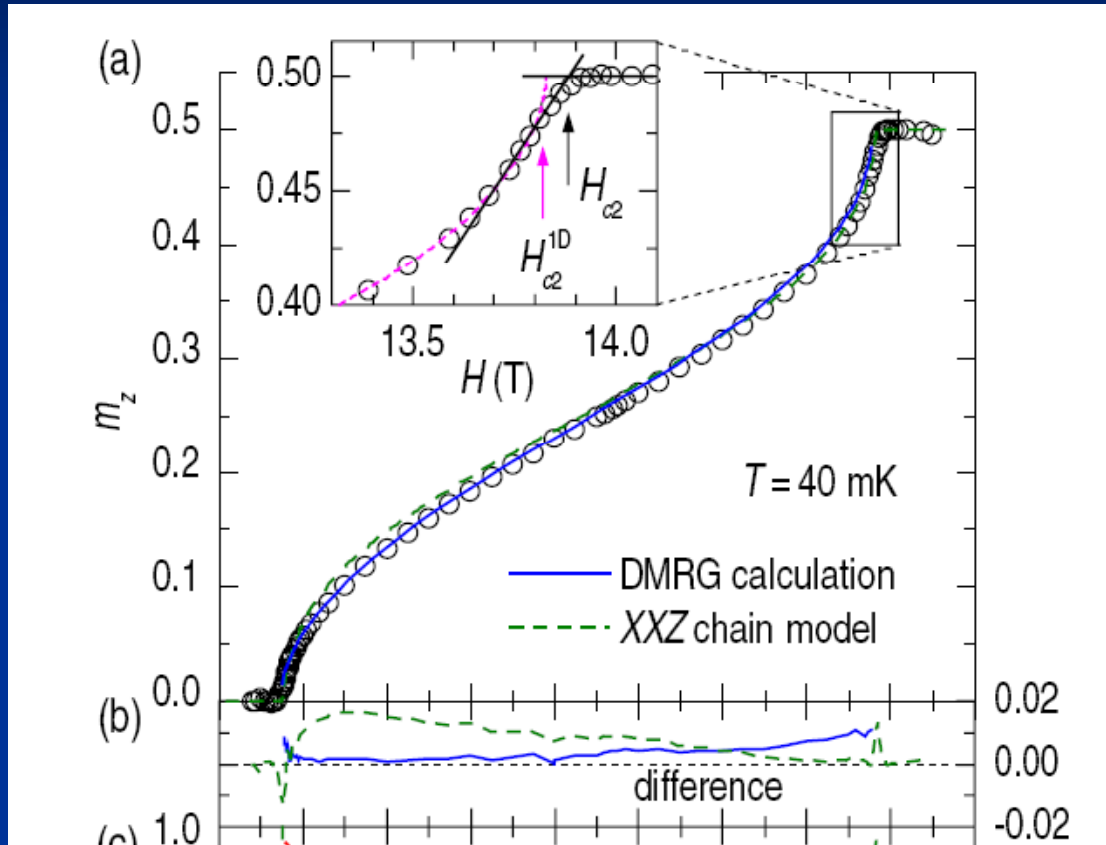

Magnetization

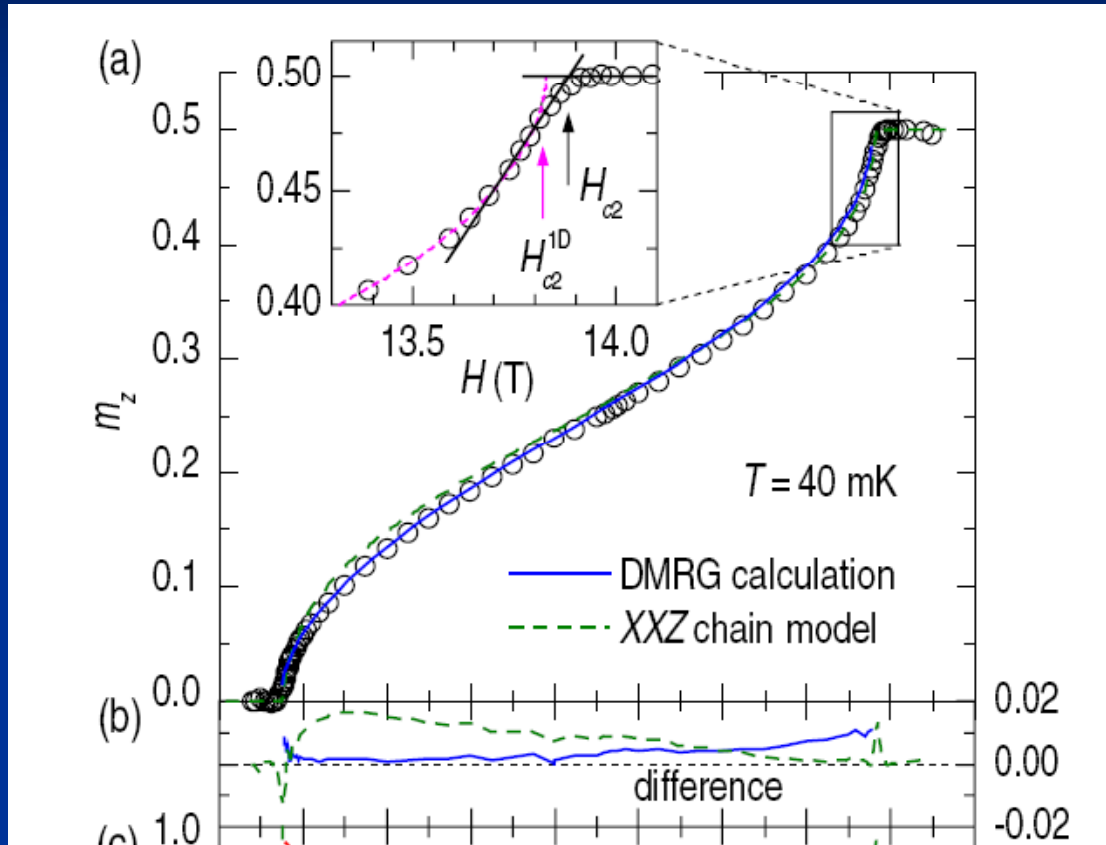

M. Klanjsek et al., PRL 101 137207 (2008)

Magnetization

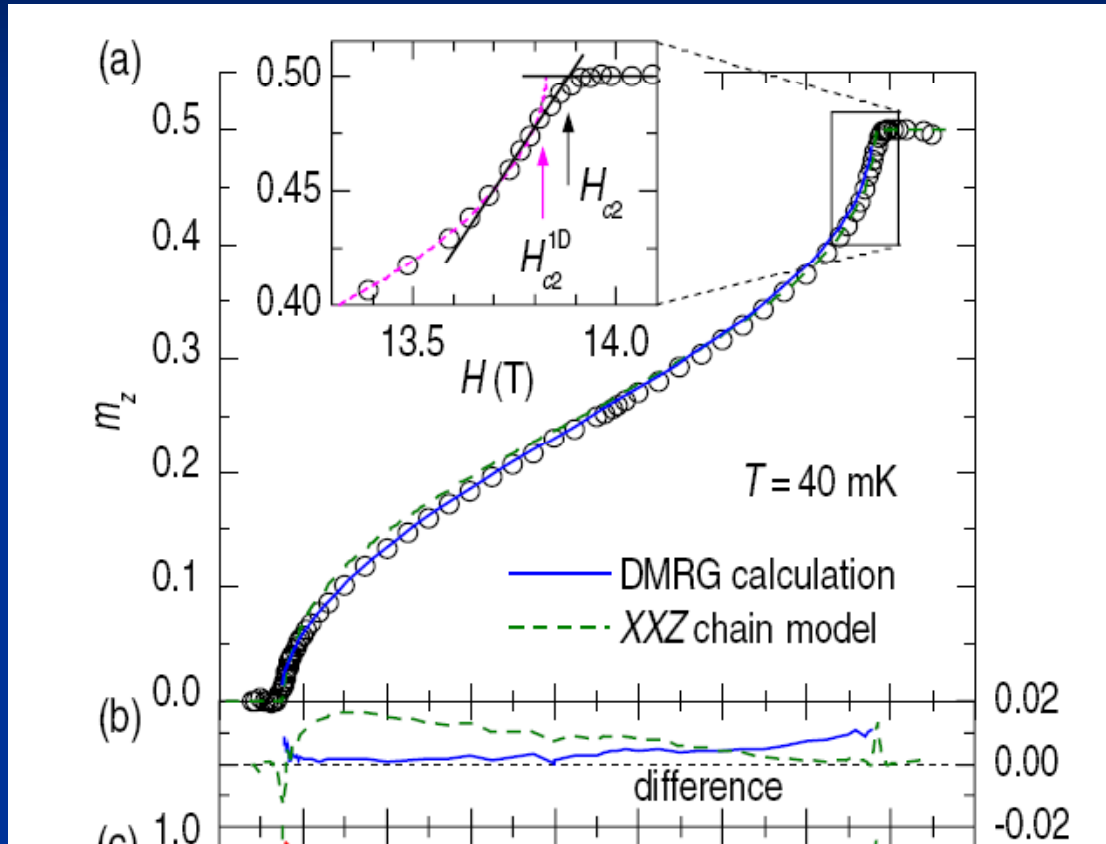

Fixes:

$$J_r = 12.9 \text{ K}$$

$$J = 3.6 \text{ K}$$



M. Klanjsek et al., PRL 101 137207 (2008)

Magnetization

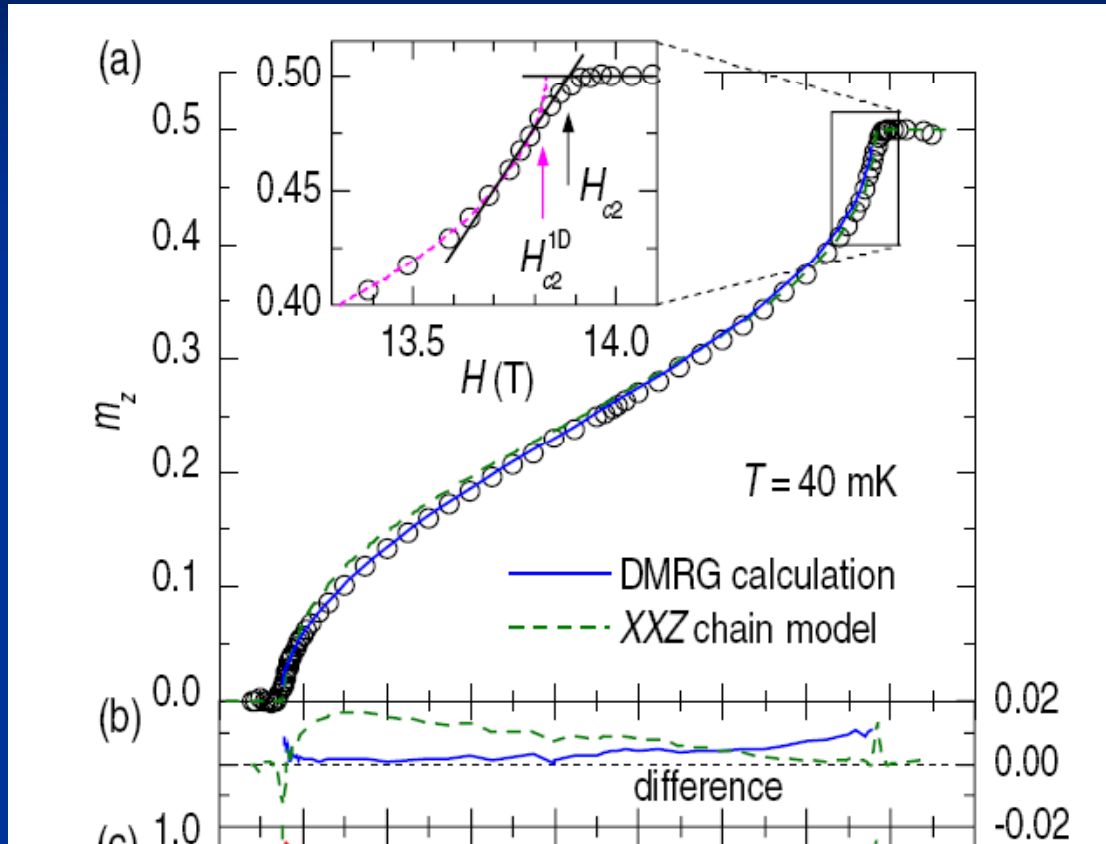

Fixes:

$$J_r = 12.9 \text{ K}$$

$$J = 3.6 \text{ K}$$



M. Klanjsek et al., PRL 101 137207 (2008)

Specific heat

Specific heat

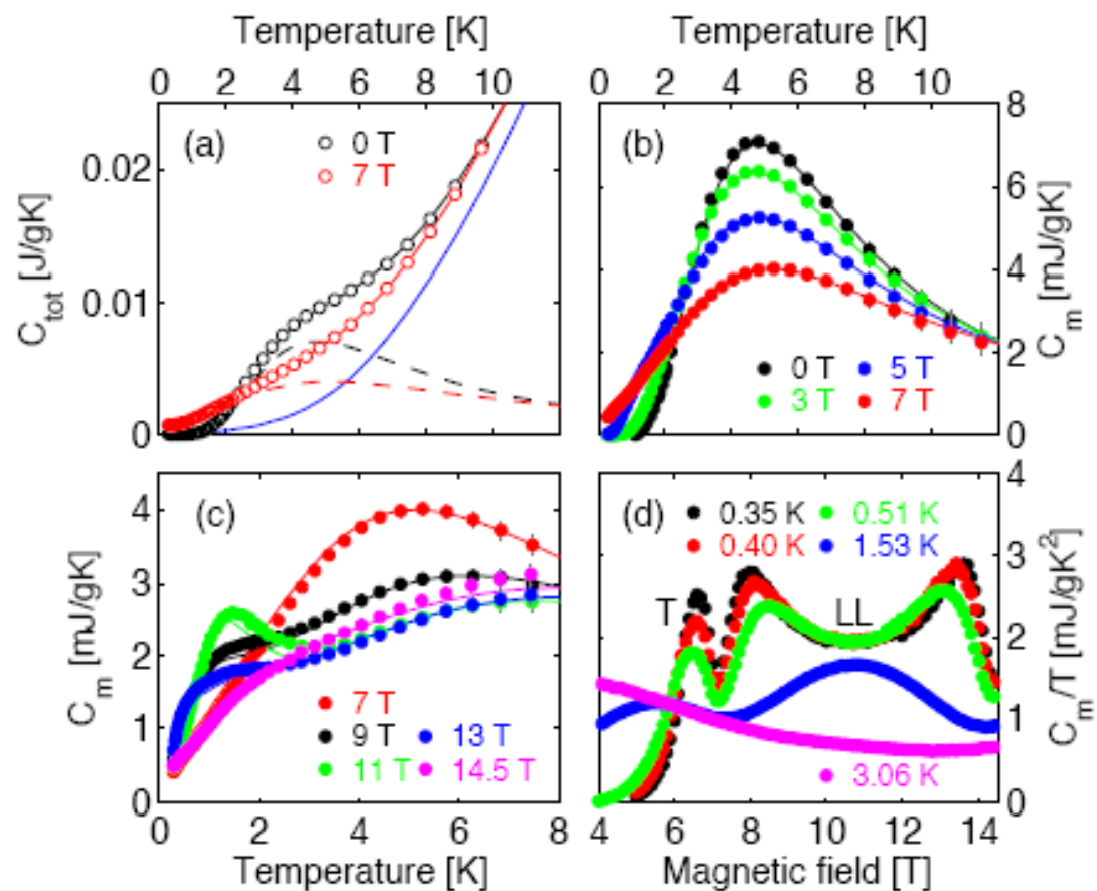

Specific heat

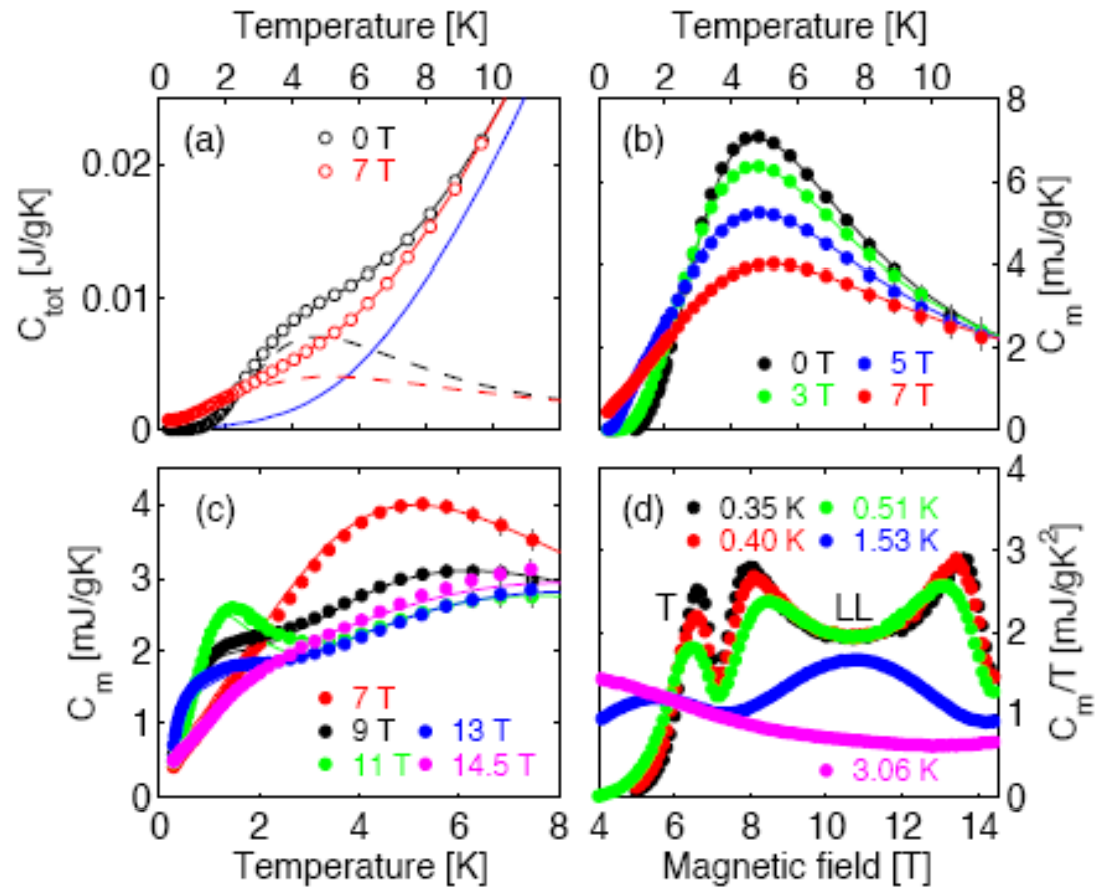

Ch. Rüegg et al.,
PRL 101, 247202 (2008)

Specific heat

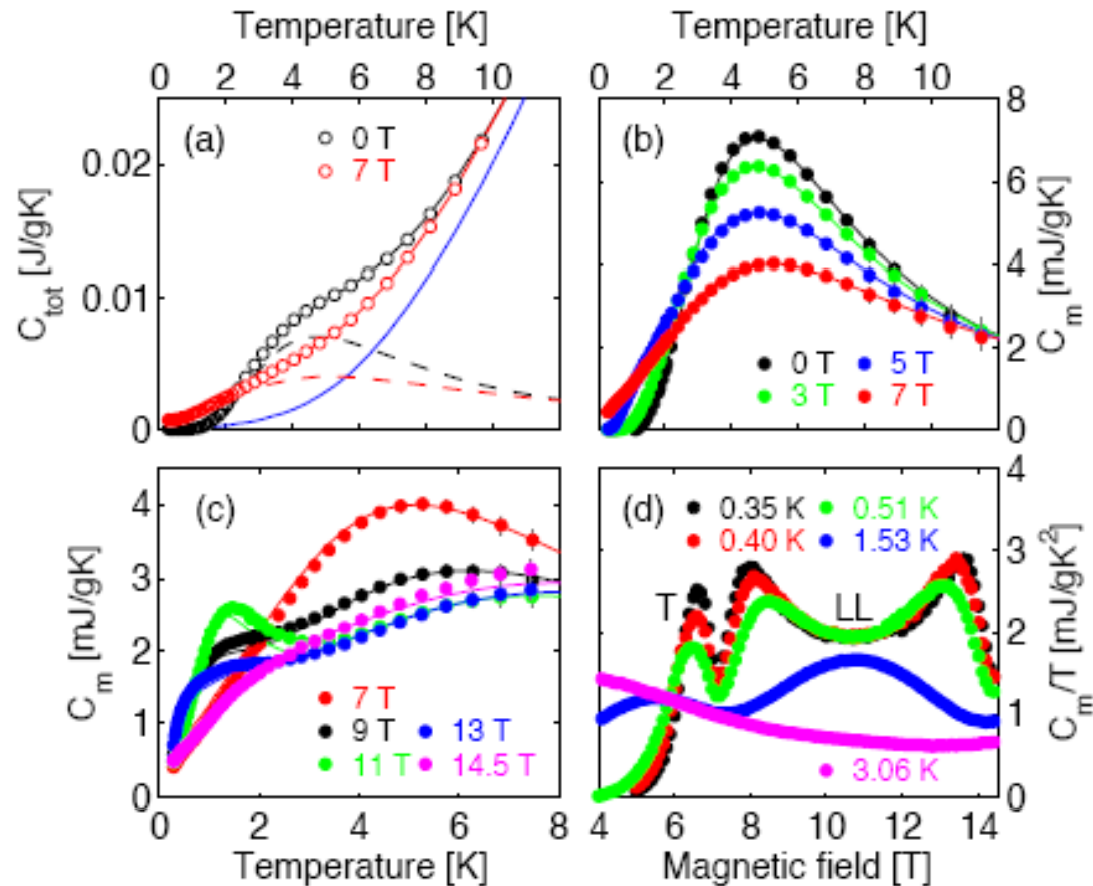

Ch. Rüegg et al.,
PRL 101, 247202 (2008)

Luttinger liquid: $C_v \propto \gamma T$

Peak : end of LL

Specific heat

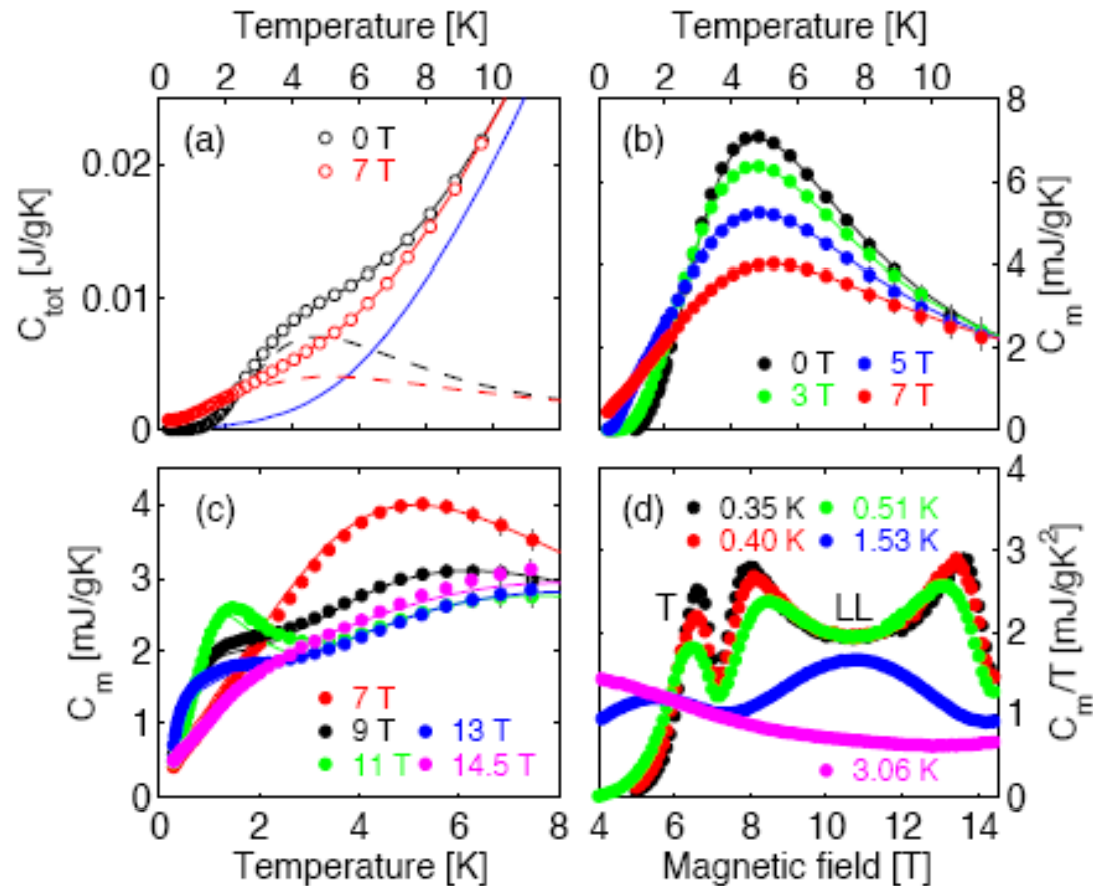

Ch. Rüegg et al.,
PRL 101, 247202 (2008)

Luttinger liquid: $C_v \propto \gamma T$

Peak : end of LL

Specific heat

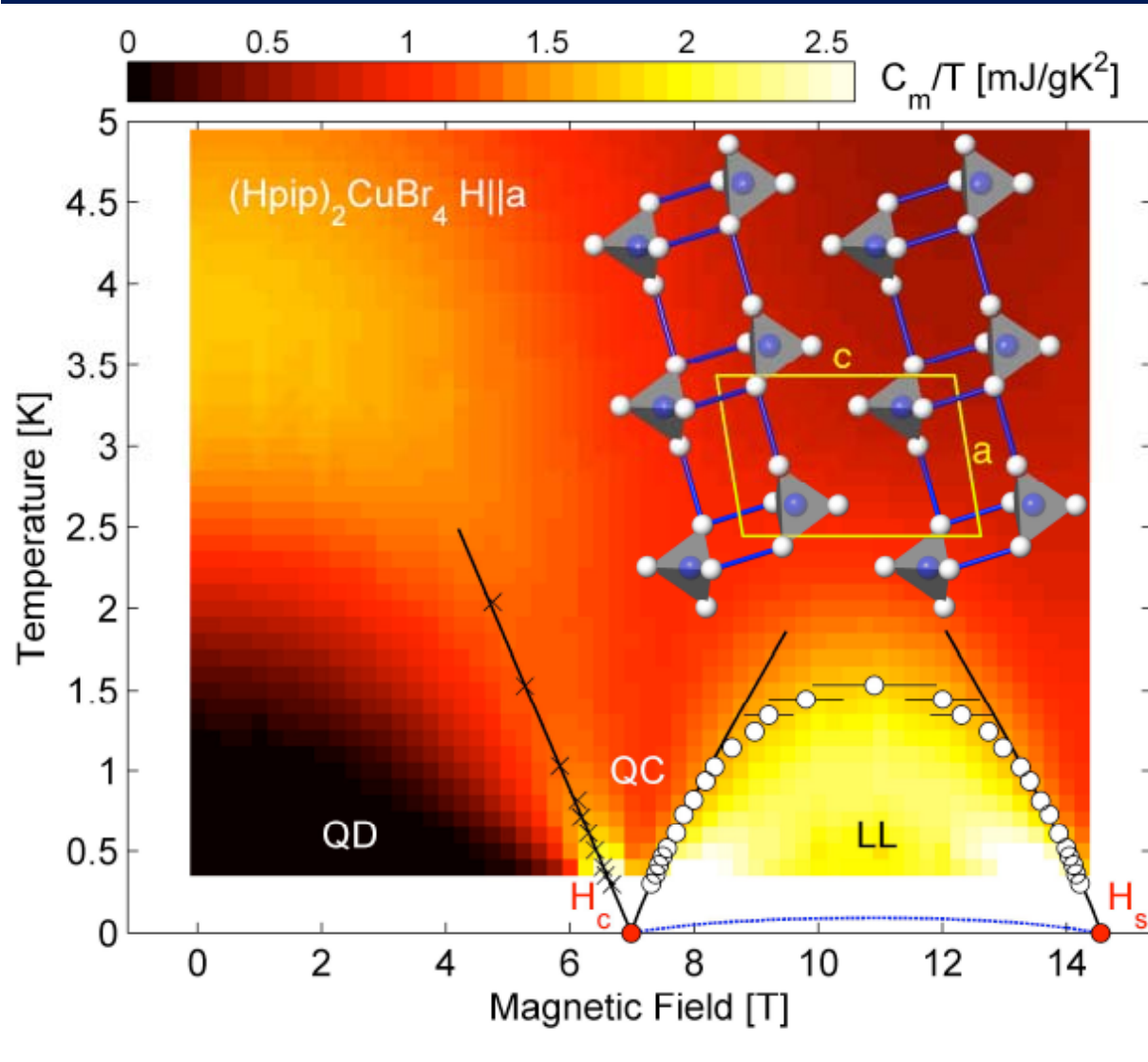

Ch. Rüegg et al., PRL
101, 247202 (2008)

Can one control LL ?

Can one control LL ?

- Compute $u(h)$ and $K(h)$ from (J_r, J, h)

Can one control LL ?

- Compute $u(h)$ and $K(h)$ from (J_r, J, h)
- No adjustable parameters !!

Can one control LL ?

- Compute $u(h)$ and $K(h)$ from (J_r, J, h)
- No adjustable parameters !!
- Get all (*several*) correlation functions

Can one control LL ?

- Compute $u(h)$ and $K(h)$ from (J_r, J, h)
- No adjustable parameters !!
- Get all (*several*) correlation functions

Allows to test for Luttinger Liquid !

Luttinger parameters

Luttinger parameters

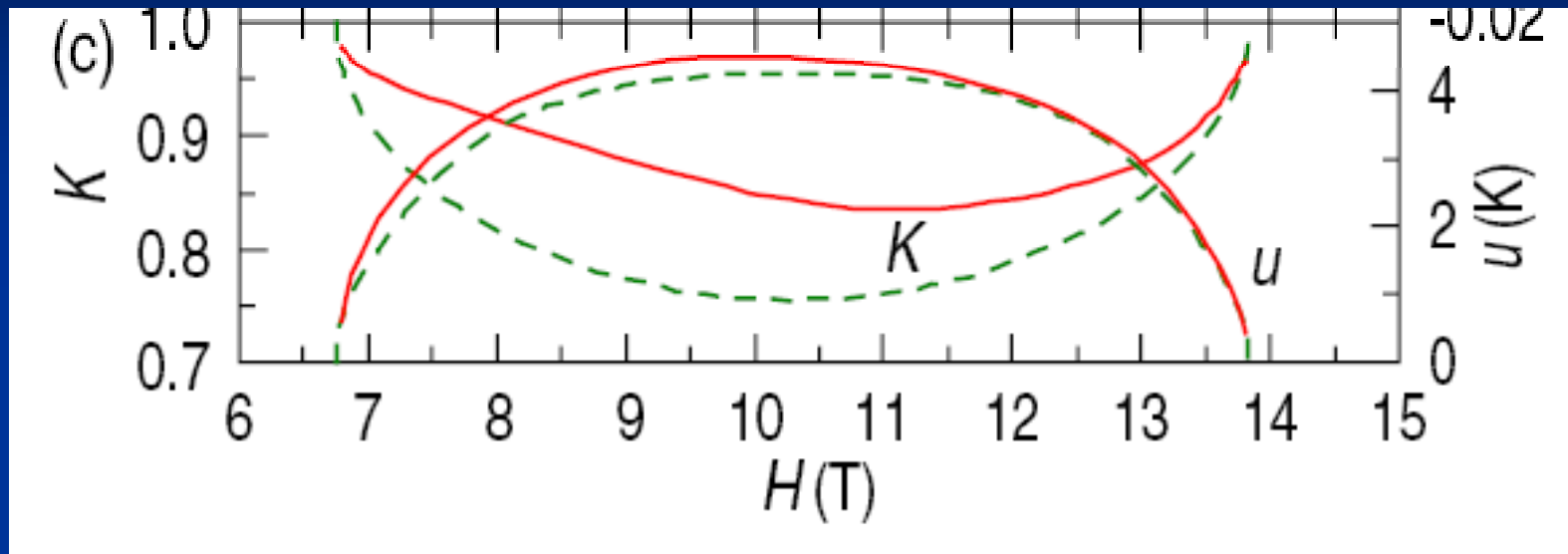

M. Klanjsek et al., PRL 101 137207 (2008)

Luttinger parameters

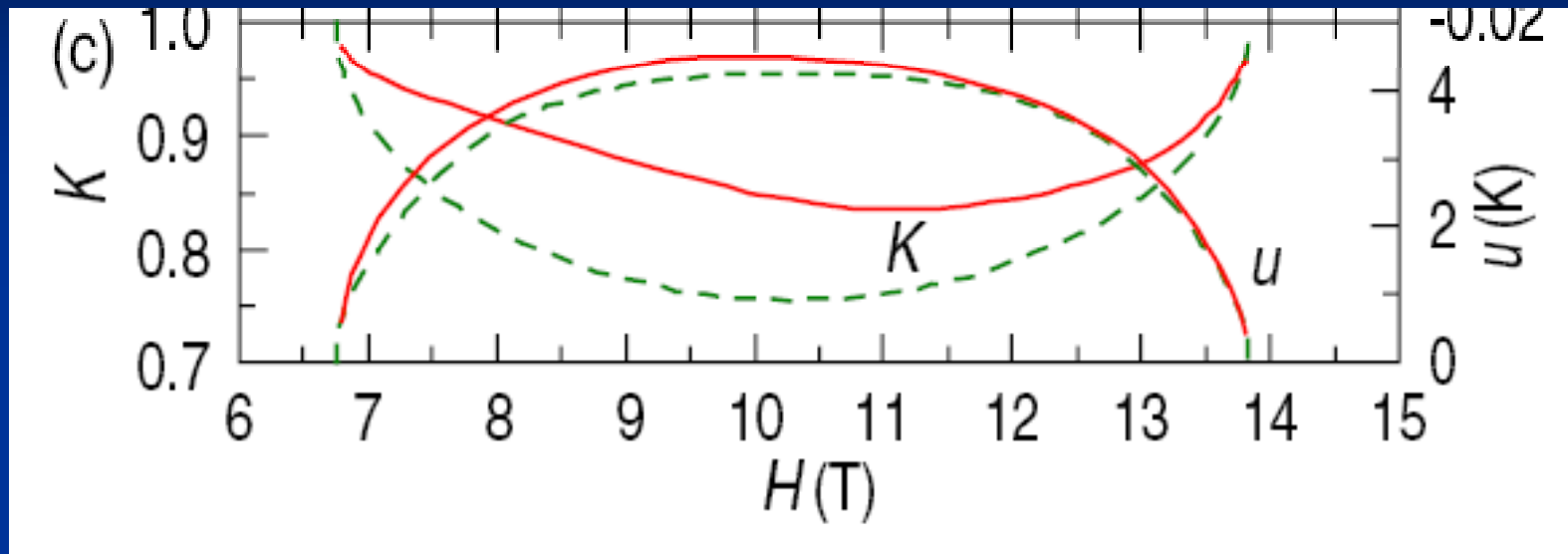

M. Klanjsek et al., PRL 101 137207 (2008)

Luttinger parameters

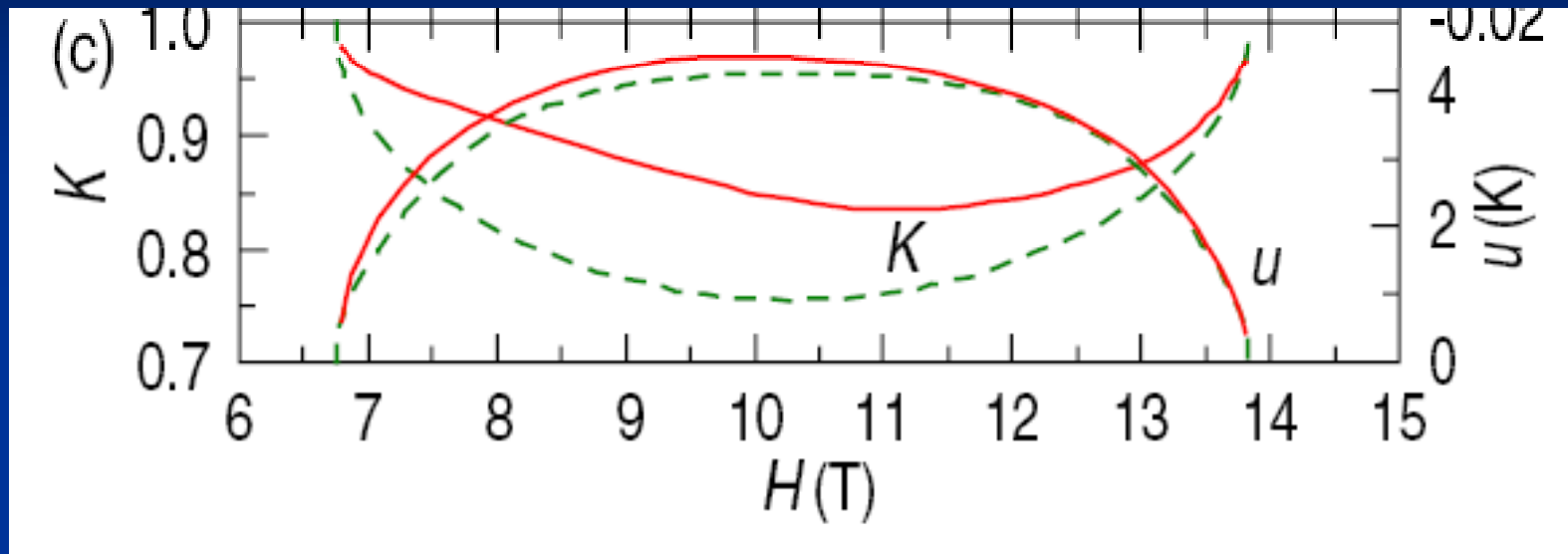

M. Klanjsek et al., PRL 101 137207 (2008)

Red : Ladder (DMRG)

Green: Strong coupling ($J_r \rightarrow \infty$) (BA)

Correlation functions

Correlation functions

M. Klanjsek et al., PRL 101 137207 (2008)

- NMR relaxation rate:

Correlation functions

M. Klanjsek et al., PRL 101 137207 (2008)

R. Chitra, TG PRB 55 5816 (97); TG, AM Tsvelik PRB 59 11398 (99)

■ NMR relaxation rate:

$$T_1^{-1} = \frac{\hbar \gamma^2 A_{\perp}^2 A_0^x}{k_B u} \cos\left(\frac{\pi}{4K}\right) B\left(\frac{1}{4K}, 1 - \frac{1}{2K}\right) \left(\frac{2\pi T}{u}\right)^{(1/2K)-1},$$

Correlation functions

M. Klanjsek et al., PRL 101 137207 (2008)

R. Chitra, TG PRB 55 5816 (97); TG, AM Tsvelik PRB 59 11398 (99)

- NMR relaxation rate:

$$T_1^{-1} = \frac{\hbar\gamma^2 A_{\perp}^2 A_0^x}{k_B u} \cos\left(\frac{\pi}{4K}\right) B\left(\frac{1}{4K}, 1 - \frac{1}{2K}\right) \left(\frac{2\pi T}{u}\right)^{(1/2K)-1},$$

- Tc to ordered phase: $1/J' = \chi_{1D}(T_c)$

Correlation functions

M. Klanjsek et al., PRL 101 137207 (2008)

R. Chitra, TG PRB 55 5816 (97); TG, AM Tsvelik PRB 59 11398 (99)

■ NMR relaxation rate:

$$T_1^{-1} = \frac{\hbar \gamma^2 A_{\perp}^2 A_0^x}{k_B u} \cos\left(\frac{\pi}{4K}\right) B\left(\frac{1}{4K}, 1 - \frac{1}{2K}\right) \left(\frac{2\pi T}{u}\right)^{(1/2K)-1},$$

■ Tc to ordered phase: $1/J' = \chi_{1D}(T_c)$

$$T_c = \frac{u}{2\pi} \left[\sin\left(\frac{\pi}{4K}\right) B^2\left(\frac{1}{8K}, 1 - \frac{1}{4K}\right) \frac{zJ'A_0^x}{2u} \right]^{2K/(4K-1)}.$$

Correlation functions

M. Klanjsek et al., PRL 101 137207 (2008)

R. Chitra, TG PRB 55 5816 (97); TG, AM Tsvelik PRB 59 11398 (99)

■ NMR relaxation rate:

$$T_1^{-1} = \frac{\hbar\gamma^2 A_{\perp}^2 A_0^x}{k_B u} \cos\left(\frac{\pi}{4K}\right) B\left(\frac{1}{4K}, 1 - \frac{1}{2K}\right) \left(\frac{2\pi T}{u}\right)^{(1/2K)-1},$$

■ T_c to ordered phase: $1/J' = \chi_{1D}(T_c)$

$$T_c = \frac{u}{2\pi} \left[\sin\left(\frac{\pi}{4K}\right) B^2\left(\frac{1}{8K}, 1 - \frac{1}{4K}\right) \frac{zJ'A_0^x}{2u} \right]^{2K/(4K-1)}.$$

Correlation functions

M. Klanjsek et al., PRL 101 137207 (2008)

R. Chitra, TG PRB 55 5816 (97); TG, AM Tsvelik PRB 59 11398 (99)

■ NMR relaxation rate:

$$T_1^{-1} = \frac{\hbar \gamma^2 A_{\perp}^2 A_0^x}{k_B u} \cos\left(\frac{\pi}{4K}\right) B\left(\frac{1}{4K}, 1 - \frac{1}{2K}\right) \left(\frac{2\pi T}{u}\right)^{(1/2K)-1},$$

■ T_c to ordered phase: $1/J' = \chi_{1D}(T_c)$

$$T_c = \frac{u}{2\pi} \left[\sin\left(\frac{\pi}{4K}\right) B^2\left(\frac{1}{8K}, 1 - \frac{1}{4K}\right) \frac{zJ'A_0^x}{2u} \right]^{2K/(4K-1)}.$$

Ordered phase



Ordered phase

- Order parameter at $T=0$

$$m_x = F(K) \sqrt{A_0^x} \left(\frac{\pi z J' A_0^x}{2u} \right)^{1/(8K-2)},$$

Ordered phase

- Order parameter at $T=0$

$$m_x = F(K) \sqrt{A_0^x} \left(\frac{\pi z J' A_0^x}{2u} \right)^{1/(8K-2)},$$

$$F(K) = \left\{ \frac{\frac{\pi^2}{\sin[\pi/(8K-1)]} \frac{8K}{8K-1} \left[\frac{\Gamma[1-(1/8K)]}{\Gamma(1/8K)} \right]^{8K/(8K-1)}}{\Gamma\left(\frac{4K}{8K-1}\right)^2 \Gamma\left(\frac{16K-3}{16K-2}\right)^2} \right\}^{(8K-1)/(8K-2)}.$$

Ordered phase

- Order parameter at $T=0$

$$m_x = F(K) \sqrt{A_0^x} \left(\frac{\pi z J' A_0^x}{2u} \right)^{1/(8K-2)},$$

$$F(K) = \left\{ \frac{\frac{\pi^2}{\sin[\pi/(8K-1)]} \frac{8K}{8K-1} \left[\frac{\Gamma[1-(1/8K)]}{\Gamma(1/8K)} \right]^{8K/(8K-1)}}{\Gamma\left(\frac{4K}{8K-1}\right)^2 \Gamma\left(\frac{16K-3}{16K-2}\right)^2} \right\}^{(8K-1)/(8K-2)}.$$

NMR



NMR

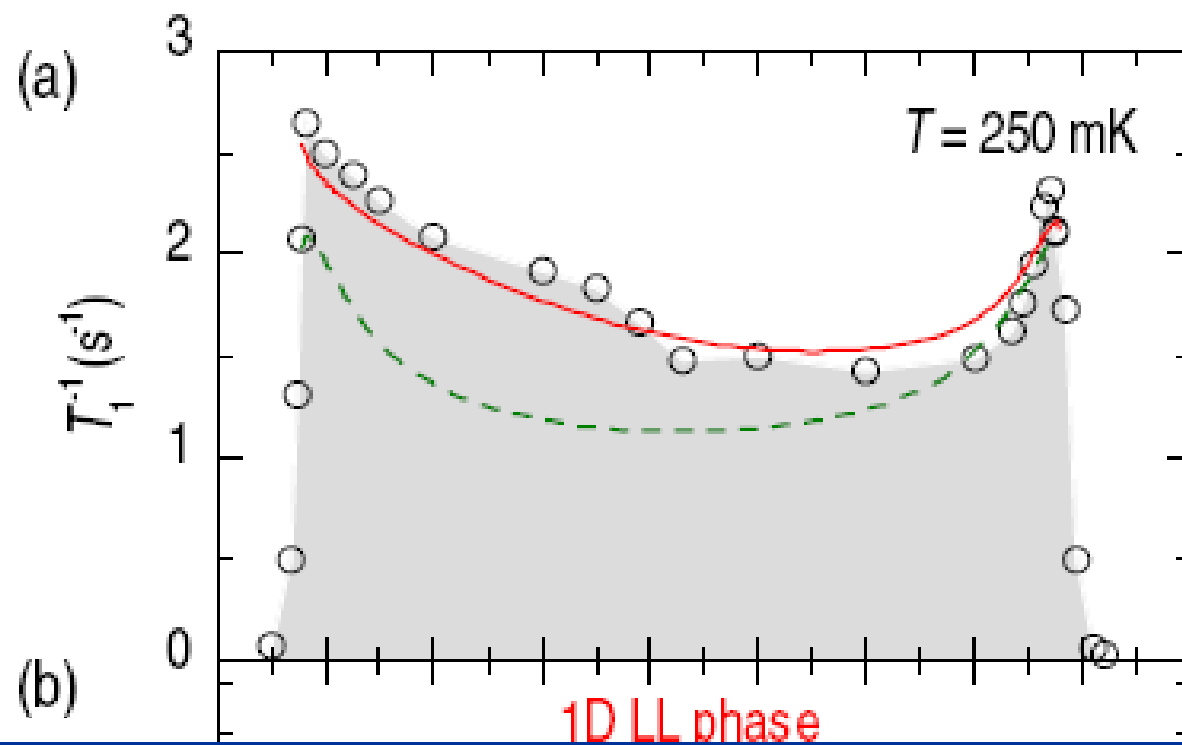

NMR

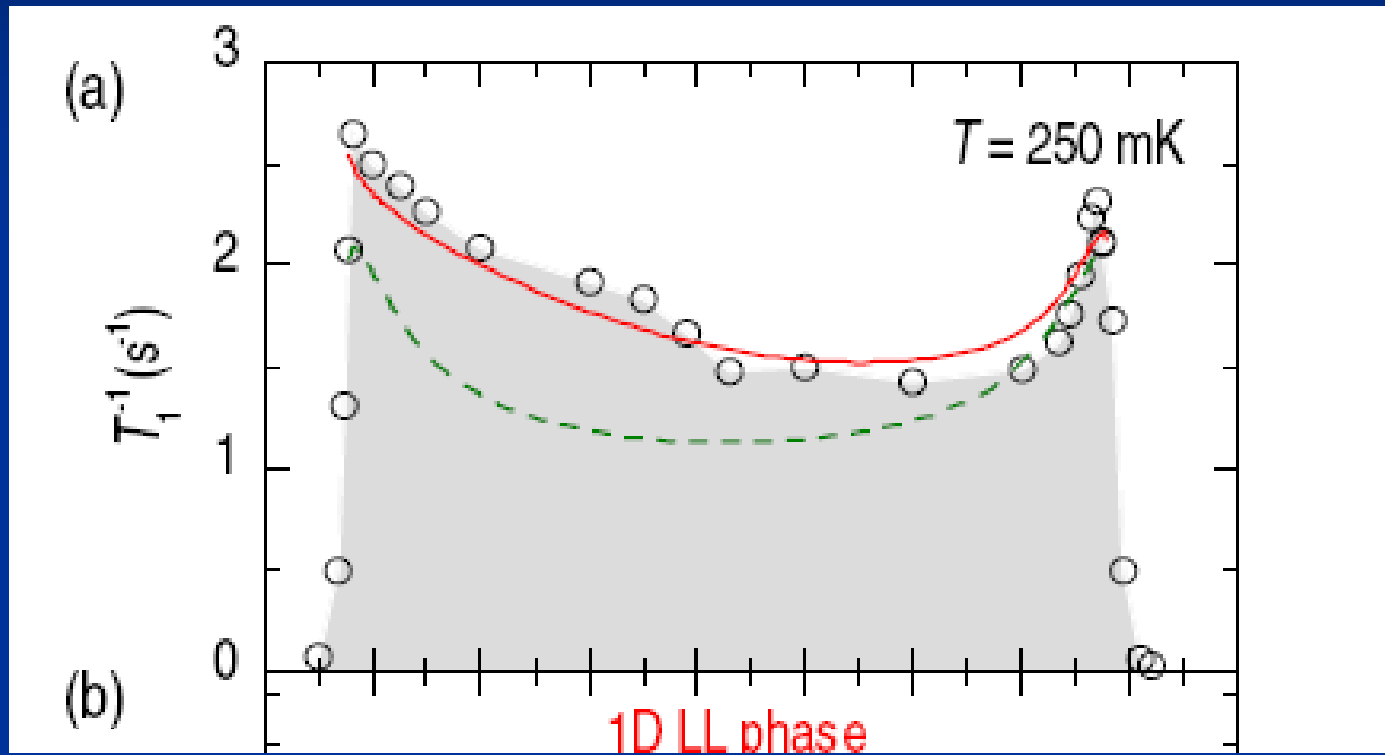

M. Klanjsek et al.,

PRL 101 137207 (2008)

NMR

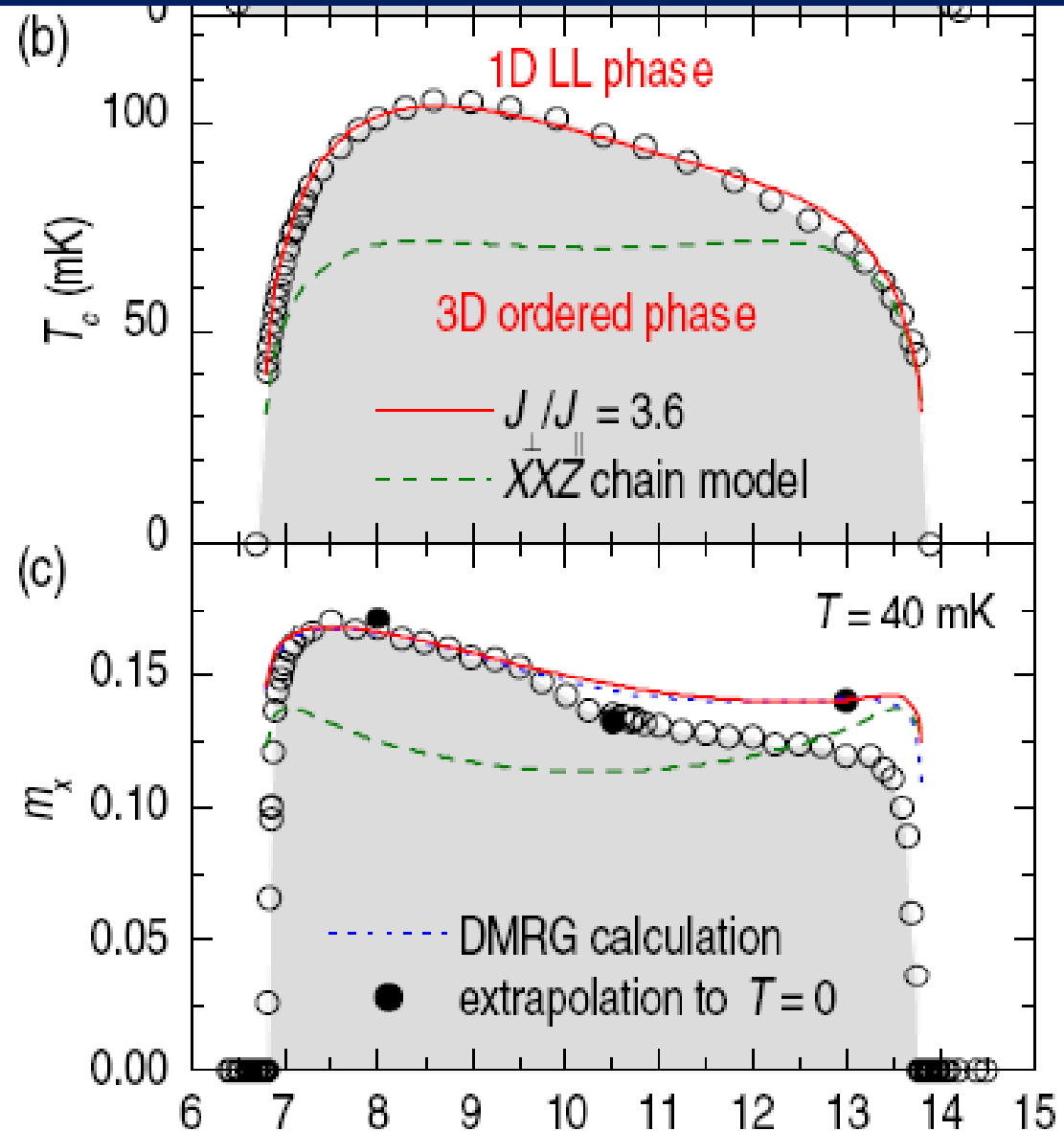
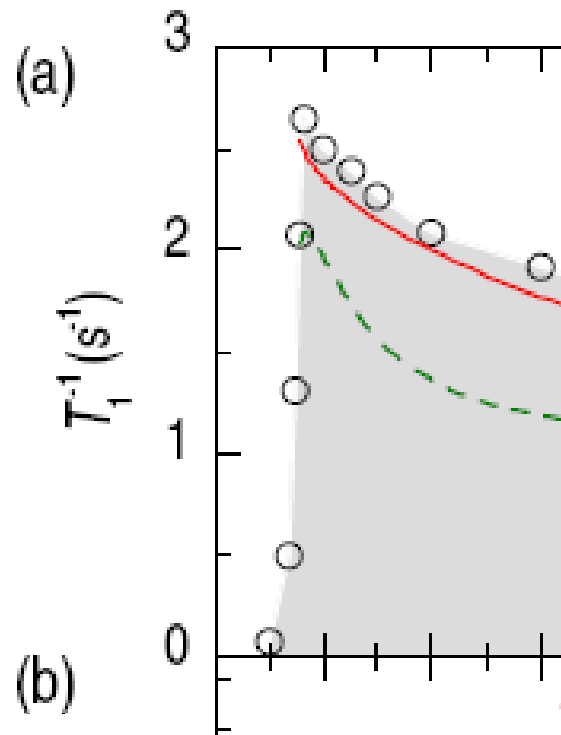

M. Klanjsek et al.,

PRL 101 137207 (2008)

Neutrons

Neutrons

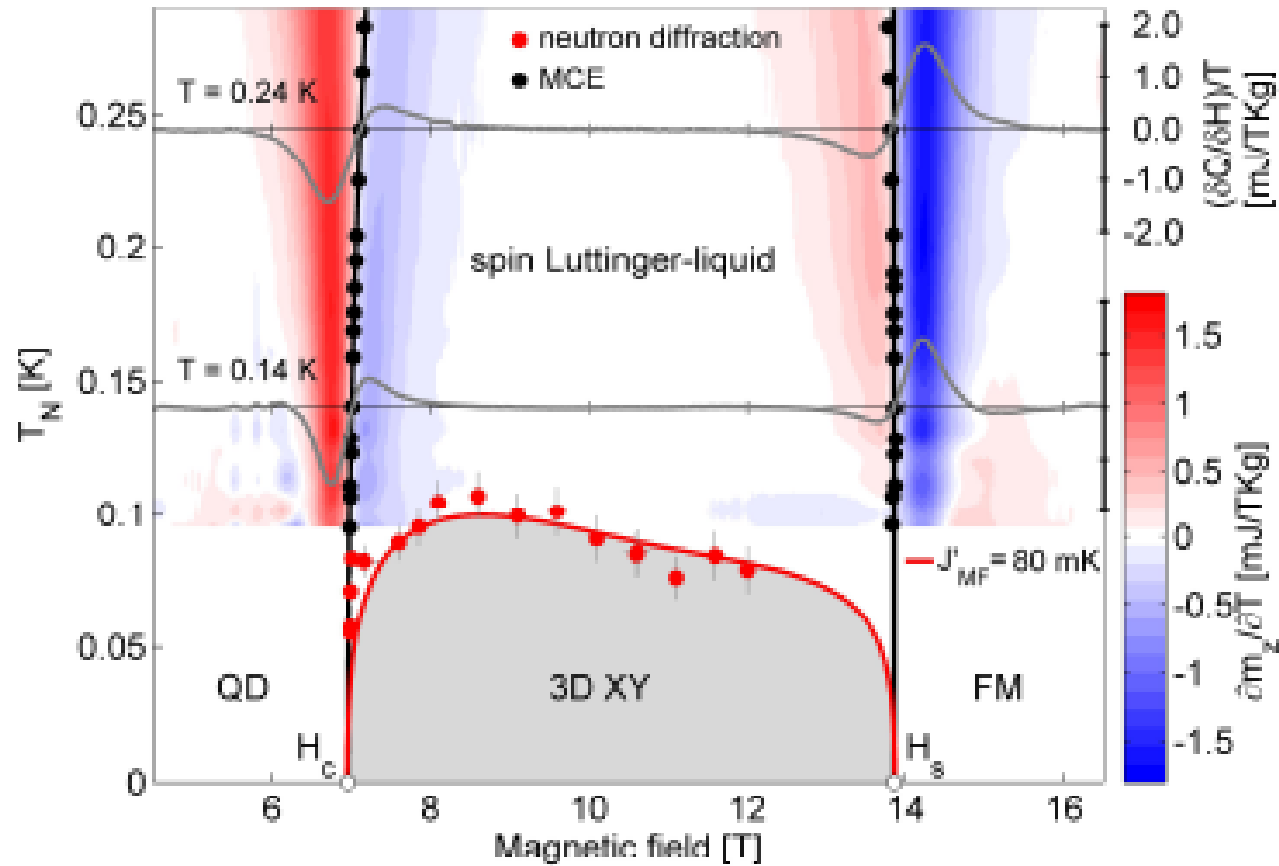

Neutrons

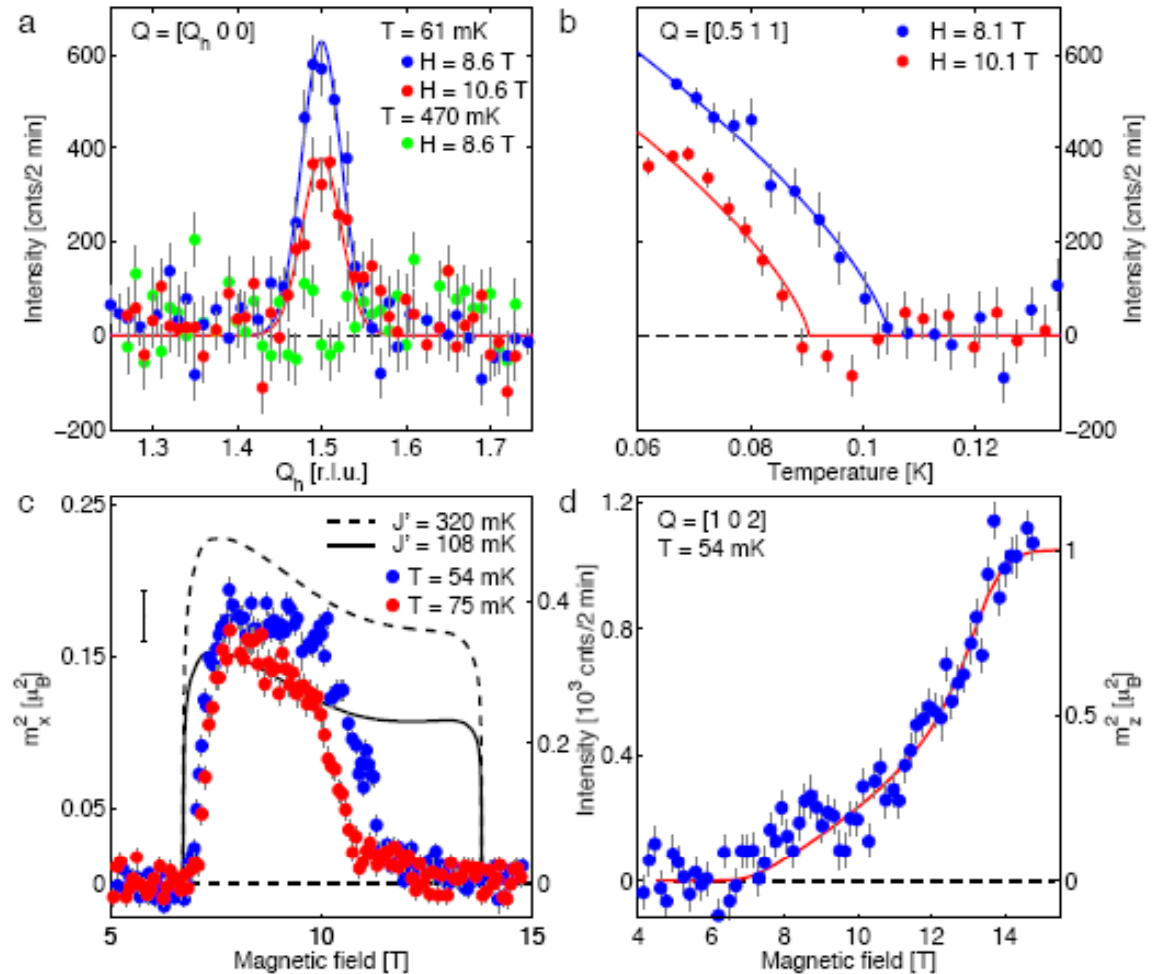
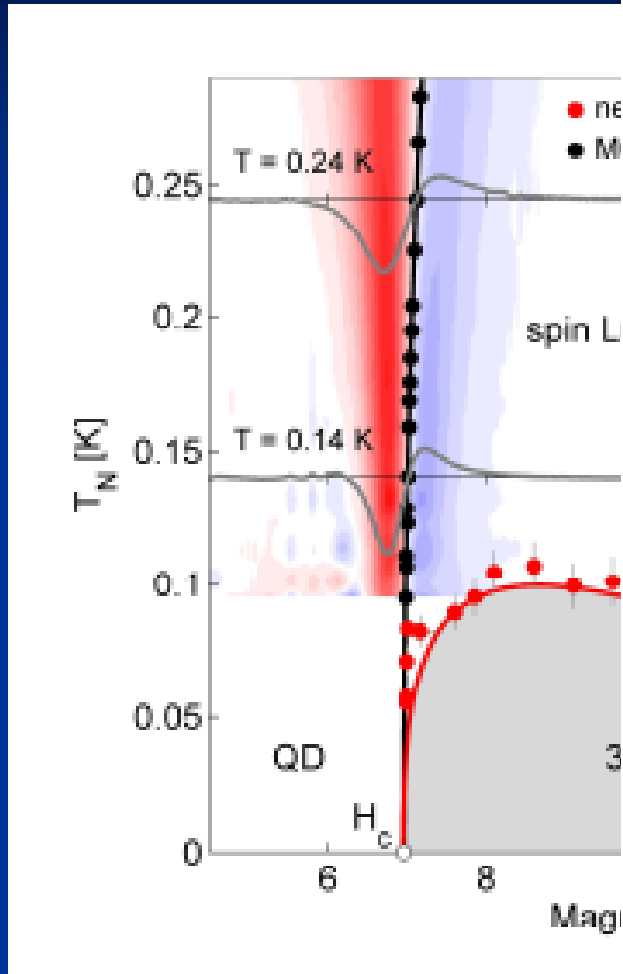

B. Thielemann et al.,
PRB 79, 020408(R) (2009)

$$J' = 27 \text{ mK}$$

Neutrons

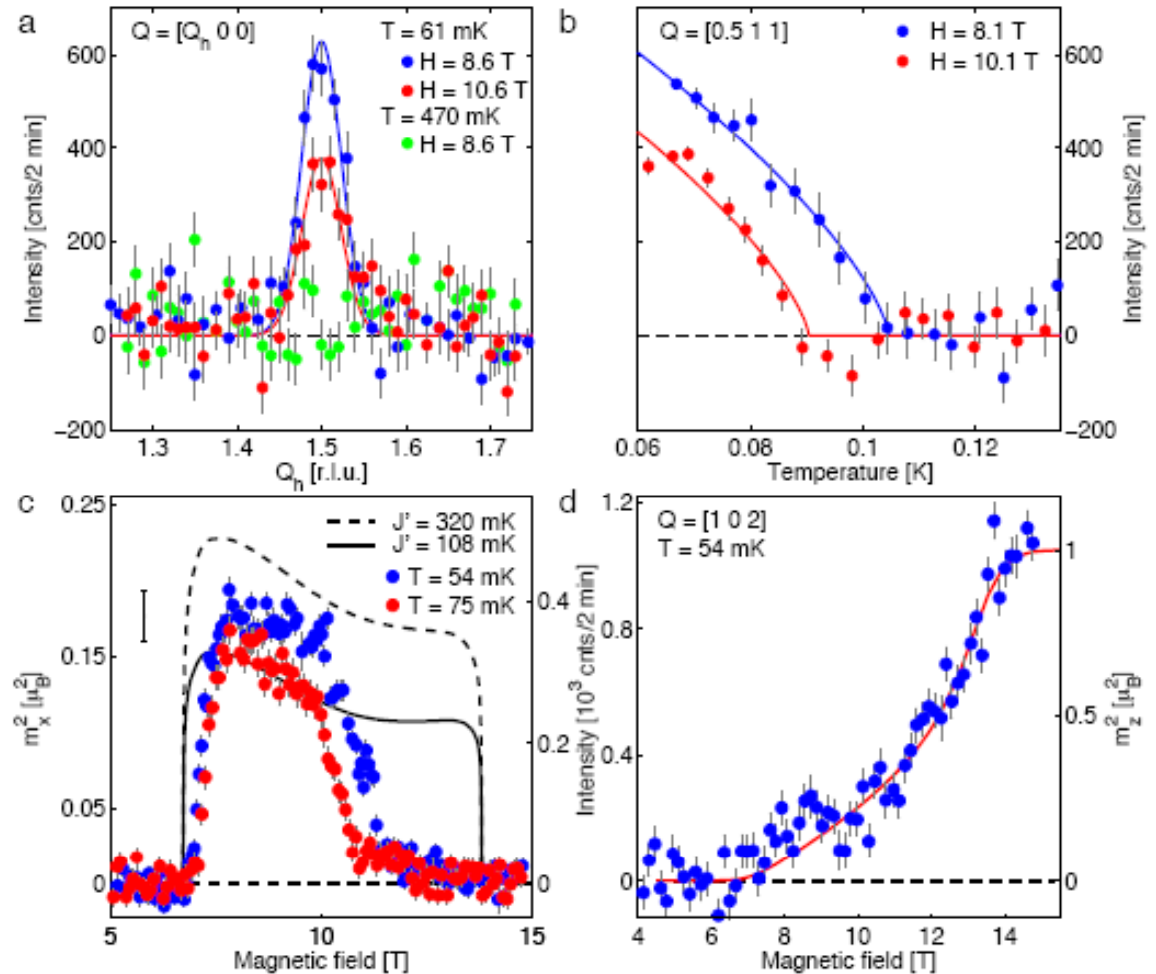
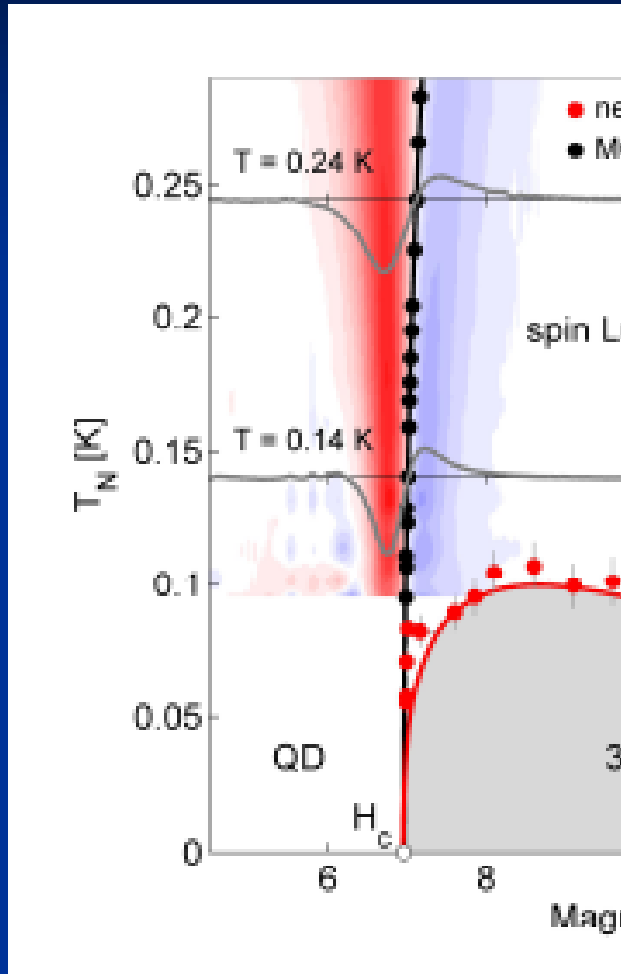

B. Thielemann et al.,
PRB 79, 020408(R) (2009)

$$J' = 27 \text{ mK}$$

Neutrons

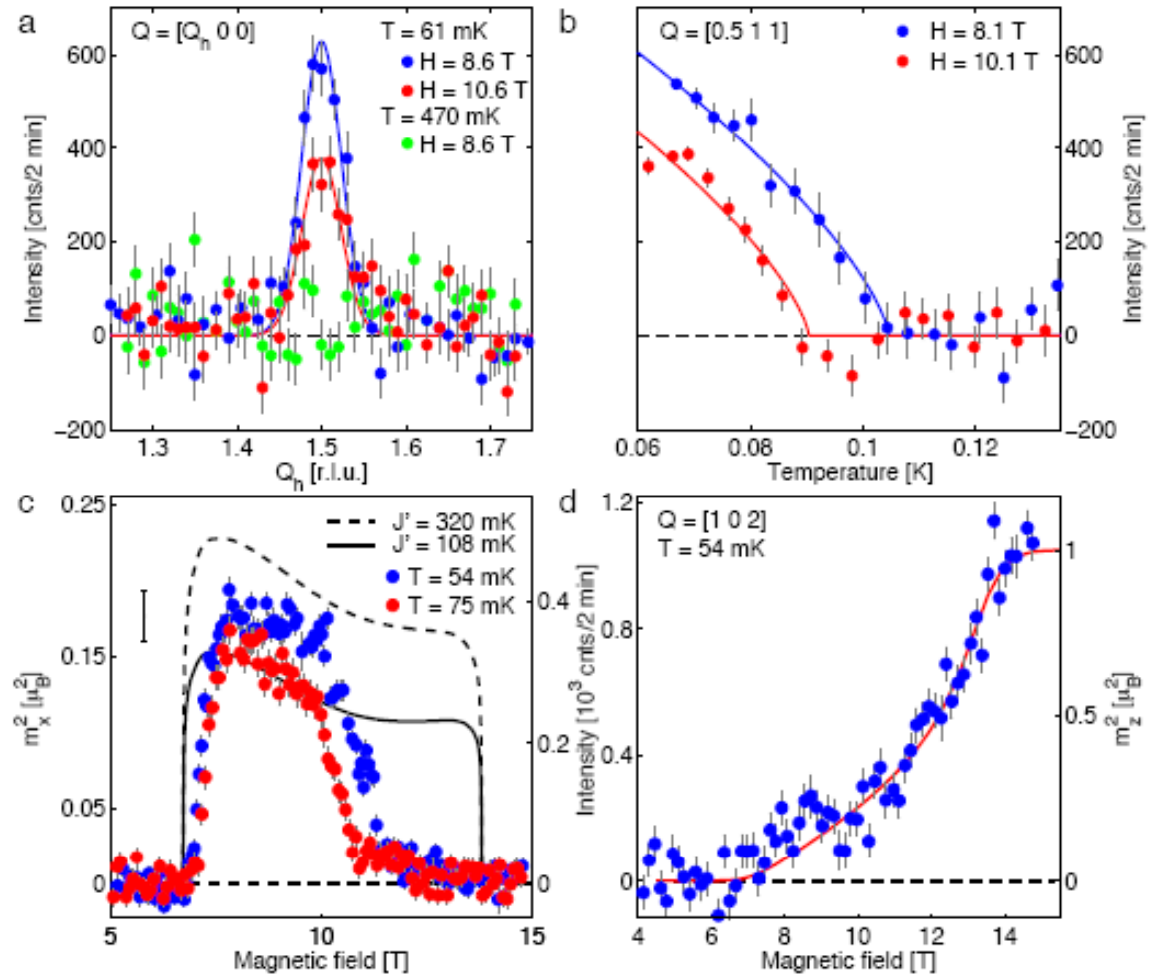
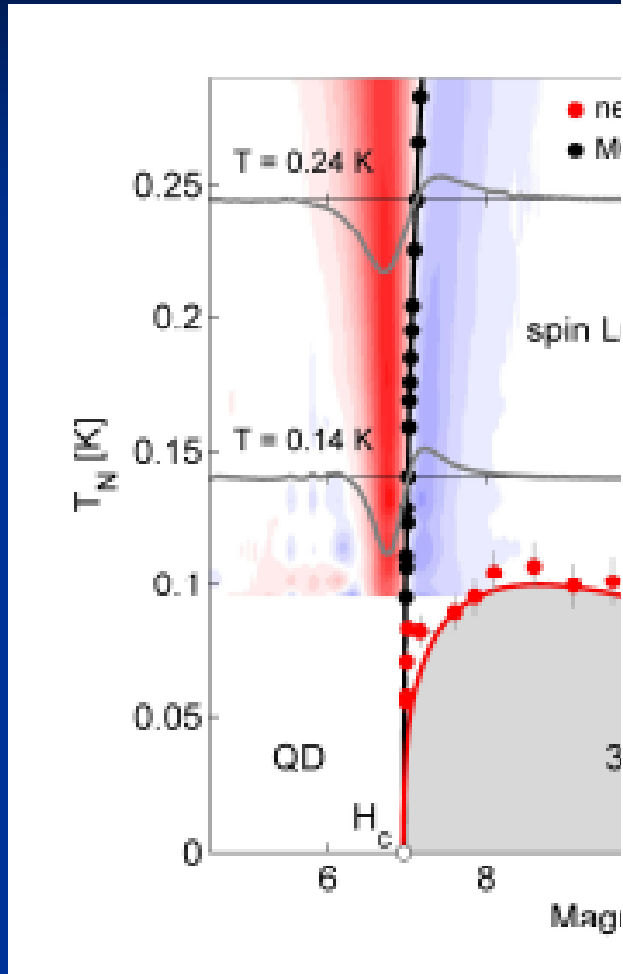

B. Thielemann et al.,
PRB 79, 020408(R) (2009)

$$J' = 27 \text{ mK}$$

End of the story ????????

Beyond Luttinger liquids

Beyond Luttinger liquids

- Luttinger liquids: allows to treat additional effects

Beyond Luttinger liquids

- Luttinger liquids: allows to treat additional effects
- 1D simple perturbation: Lattice (Mott transition), disorder (Bose glass) etc.

Beyond Luttinger liquids

- Luttinger liquids: allows to treat additional effects
- 1D simple perturbation: Lattice (Mott transition), disorder (Bose glass) etc.
- Major deviations from Luttinger liquids
(hard problems 😊)

Luttinger liquid + bath or noise



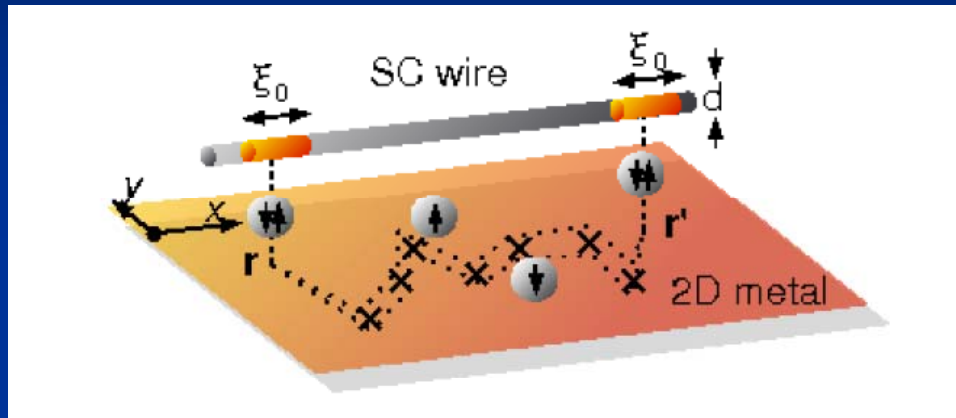

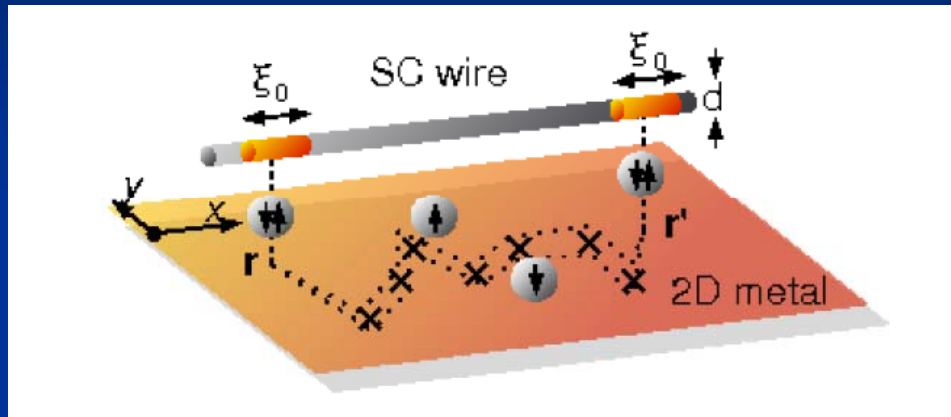

A. Lobos, A. Iucci, M. Muler,
TG PRB 80 214515 (09)

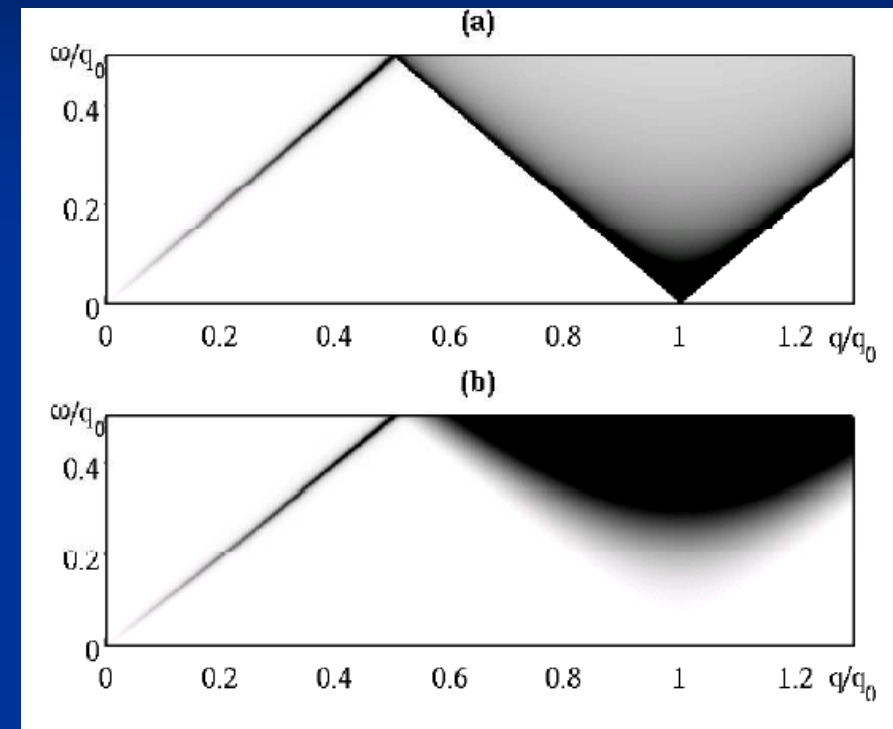
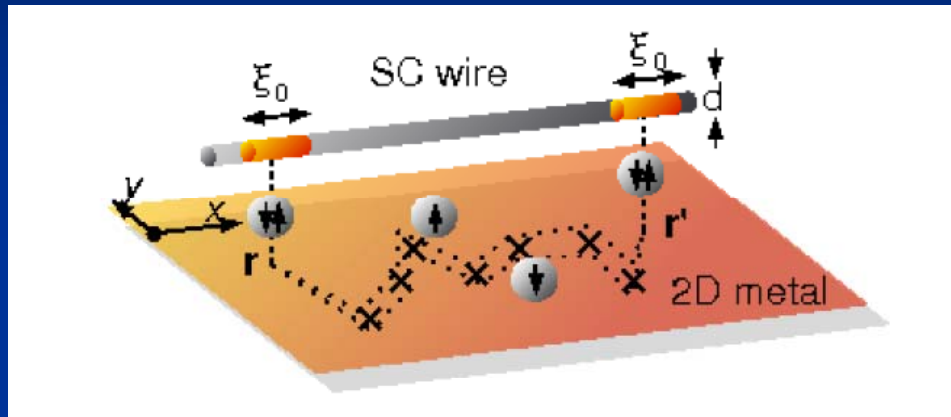

A. Lobos, A. Iucci, M. Muler,
 TG PRB 80 214515 (09)

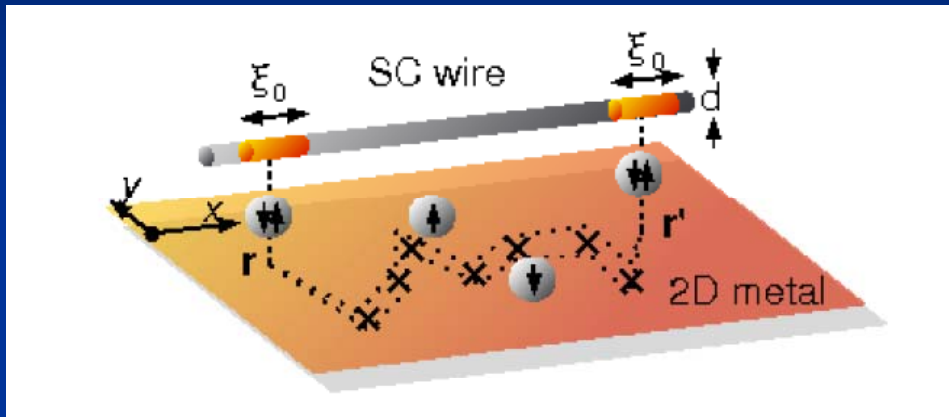
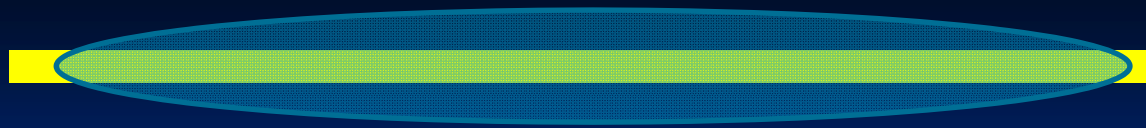

A. Lobos, A. Iucci, M. Muler,
 TG PRB 80 214515 (09)

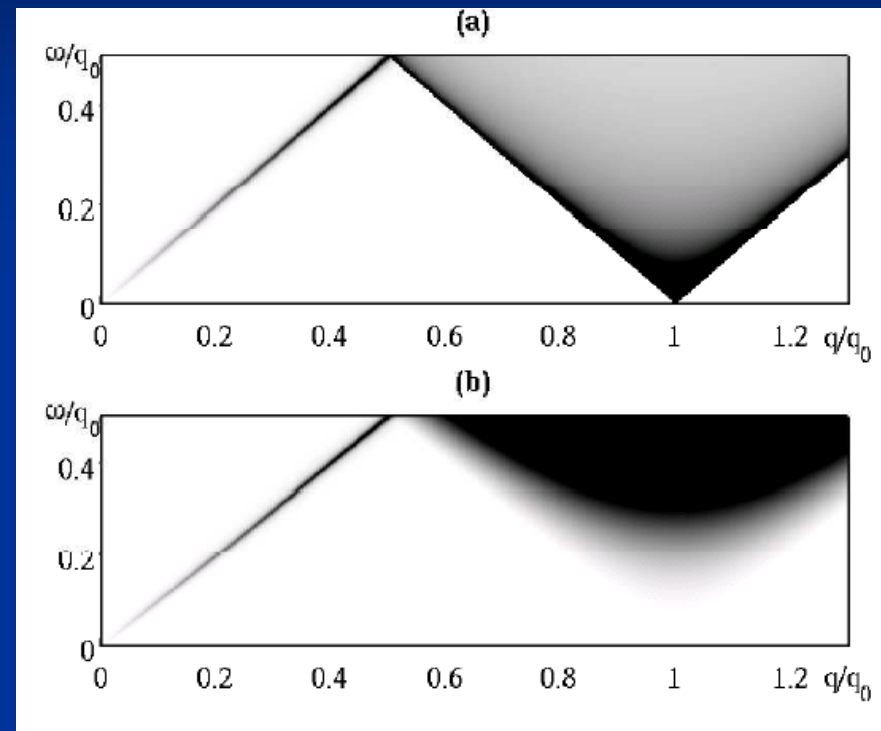

E. Dalla Torre, E. Demler, TG,
 E. Altman, Arxiv/0908.3345

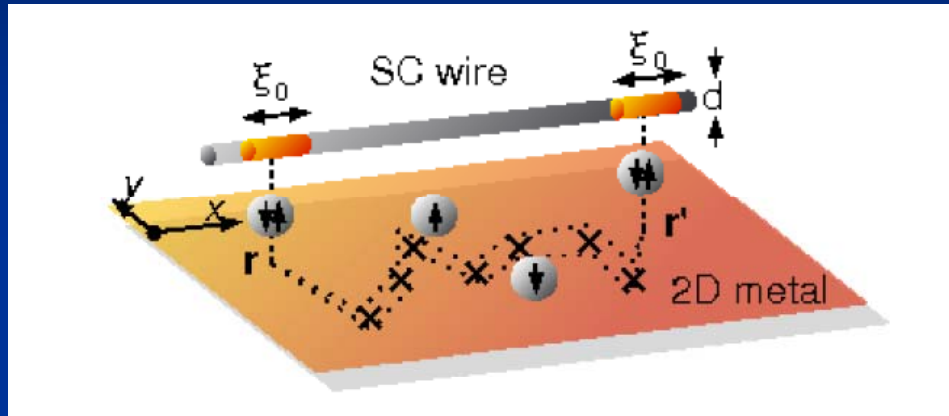
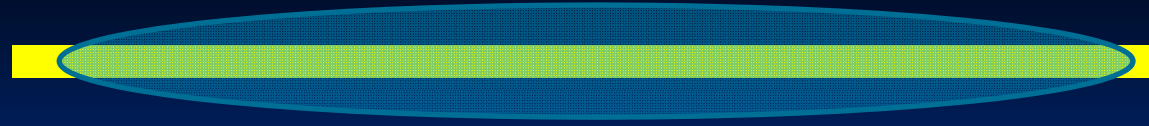

A. Lobos, A. Iucci, M. Muler,
TG PRB 80 214515 (09)

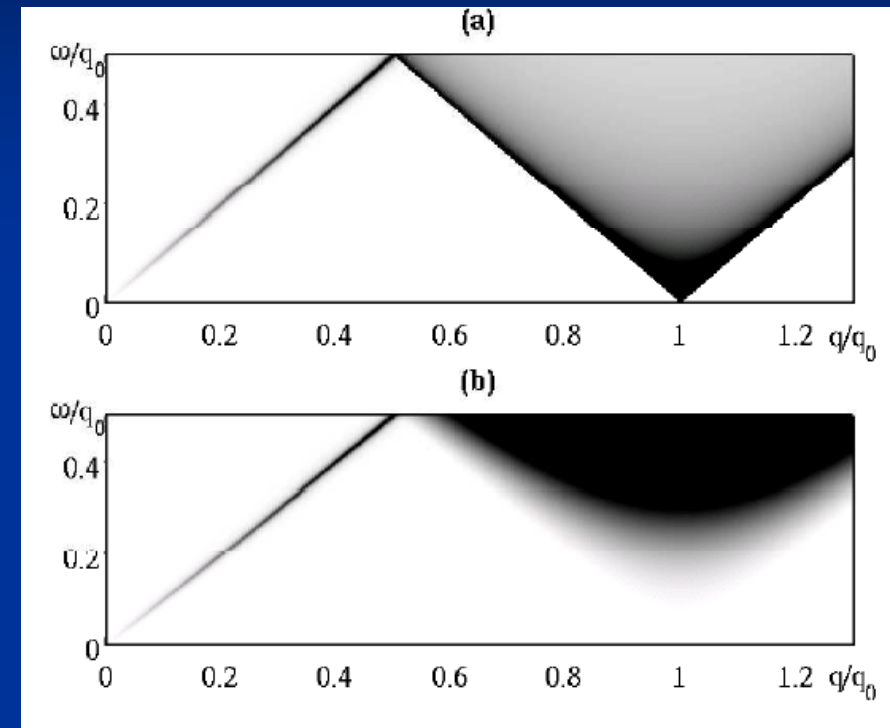

E. Dalla Torre, E. Demler, TG,
E. Altman, Arxiv/0908.3345

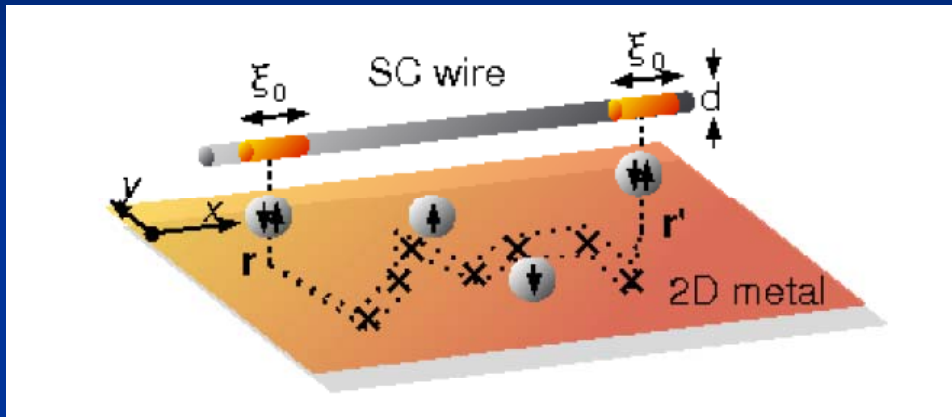
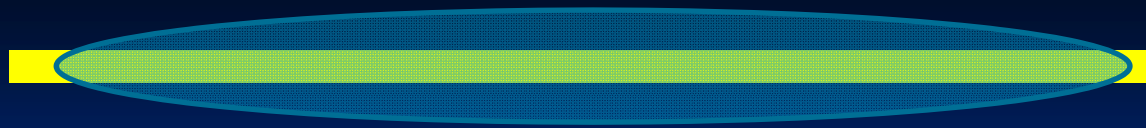

A. Lobos, A. Iucci, M. Muler,
 TG PRB 80 214515 (09)

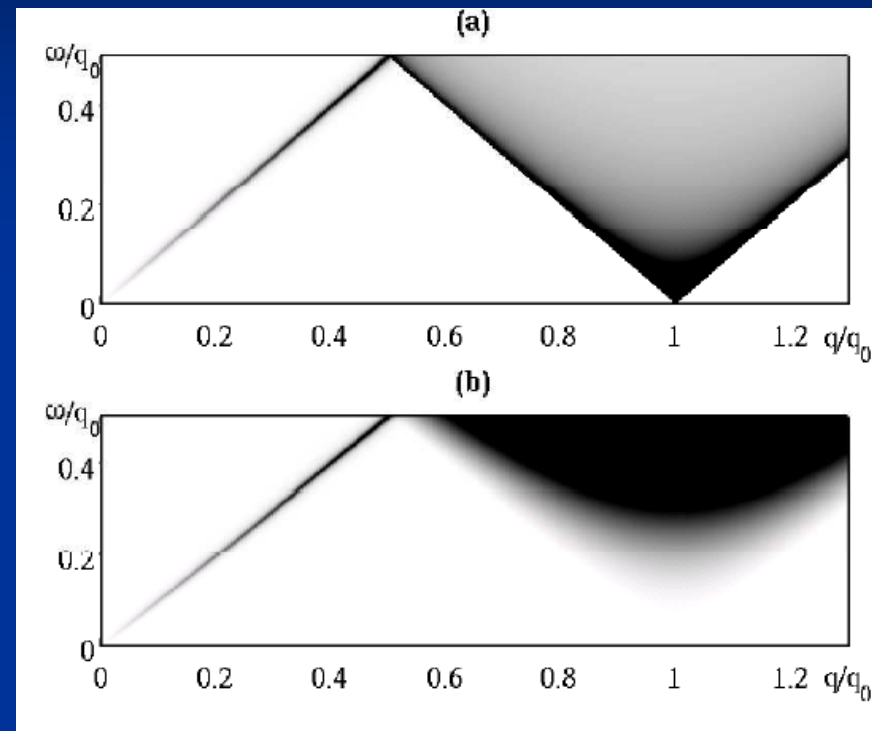

E. Dalla Torre, E. Demler, TG,
 E. Altman, Arxiv/0908.3345

Coupled 1D chains: deconfinement

Deconfinement

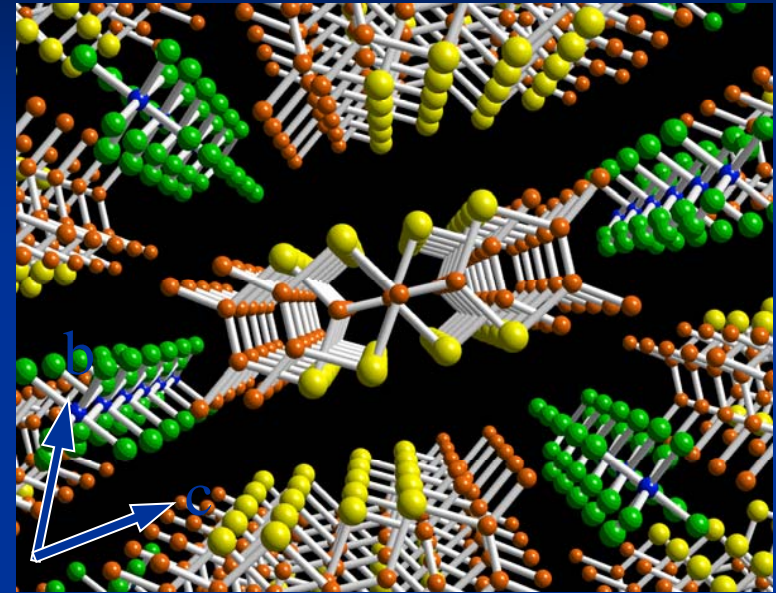
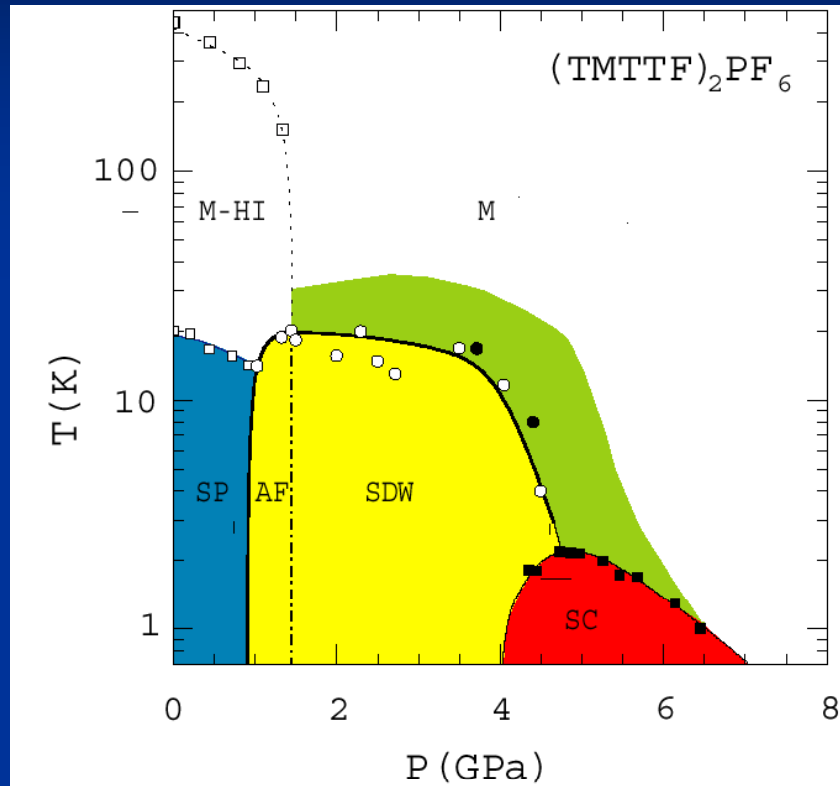

D. Jaccard et al., J. Phys. C, 13 L89 (2001)

Deconfinement

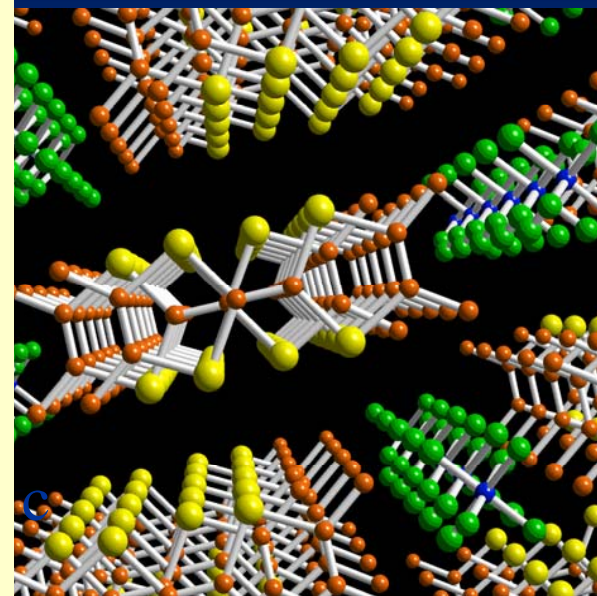
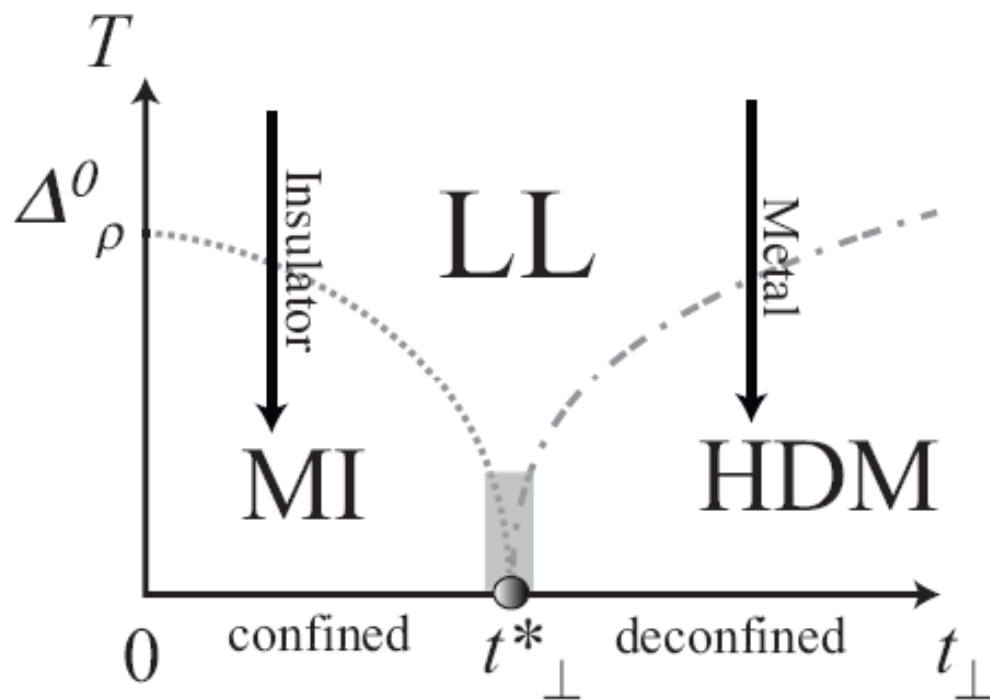

TG Chemical
Review 104 5037
(2004)

D. Jaccard et al., J. Phys. C, 13 L89 (2001)

Deconfinement

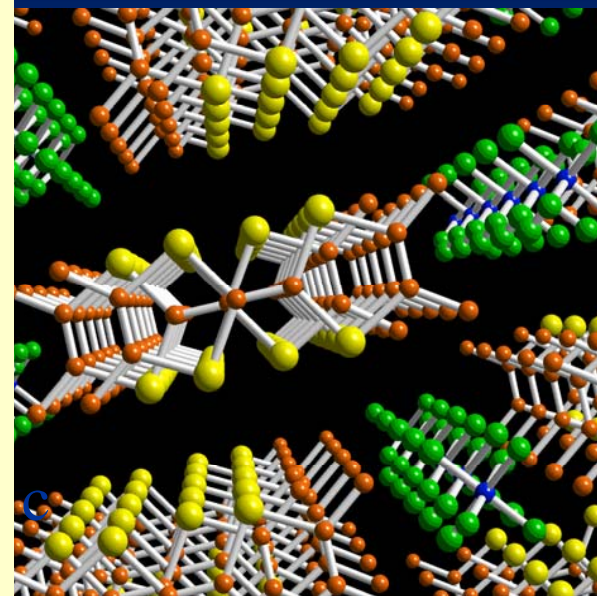
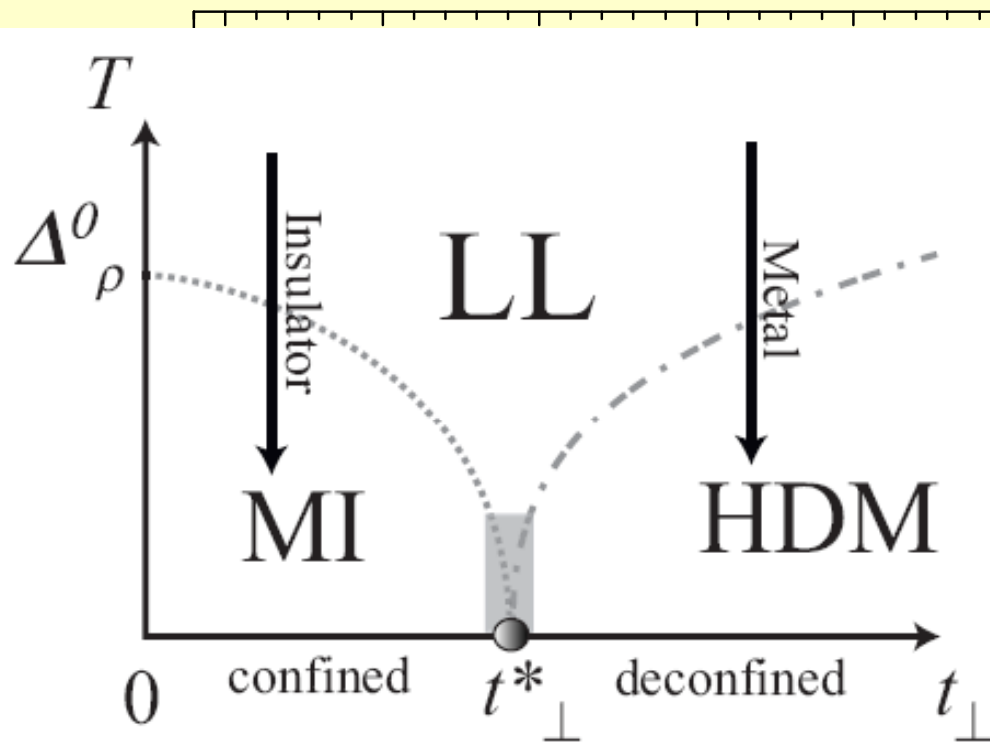

TG Chemical
Review 104 5037
(2004)

P. Auban-Senzier, D. Jérôme, C. Carcel and J.M. Fabre J de Physique IV, (2004)

A. Pashkin, M. Dressel, M. Hanfland, C. A. Kuntscher, arxiv/0909.4795

D. Jaccard et al., J. Phys. C, 13 L89 (2001)

Deconfinement

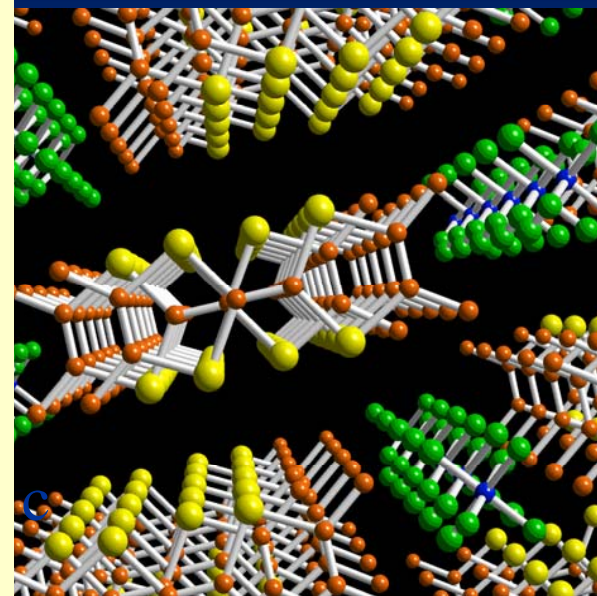
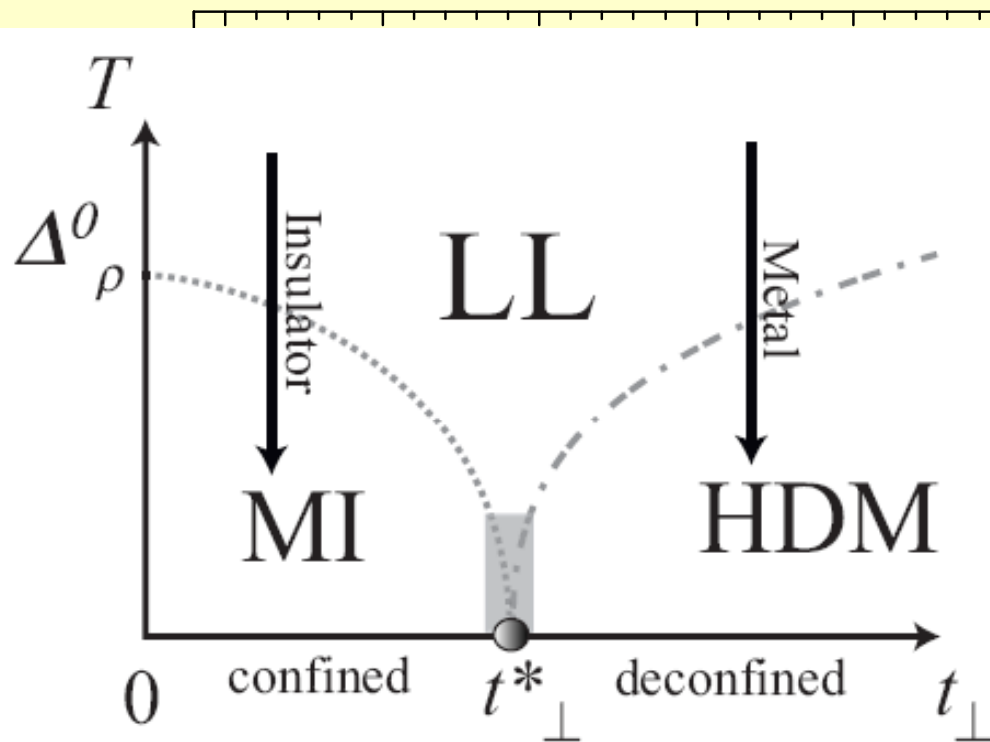

TG Chemical
Review 104 5037
(2004)

P. Auban-Senzier, D. Jérôme, C. Carcel and J.M. Fabre J de Physique IV, (2004)

A. Pashkin, M. Dressel, M. Hanfland, C. A. Kuntscher, arxiv/0909.4795

D. Jaccard et al., J. Phys. C, 13 L89 (2001)

Deconfinement

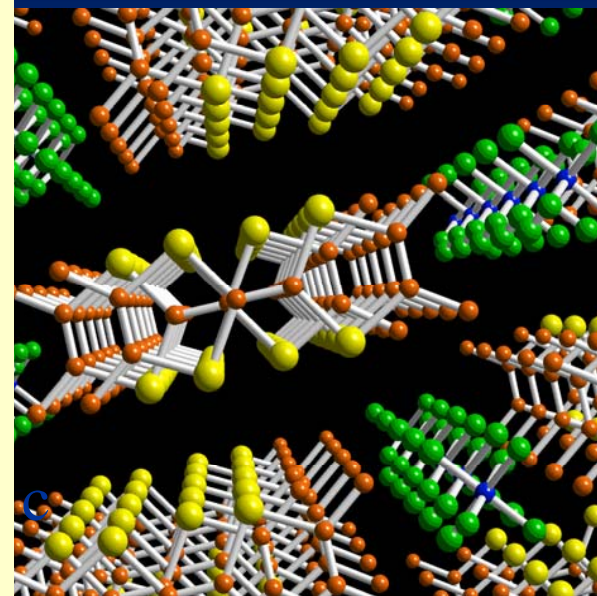
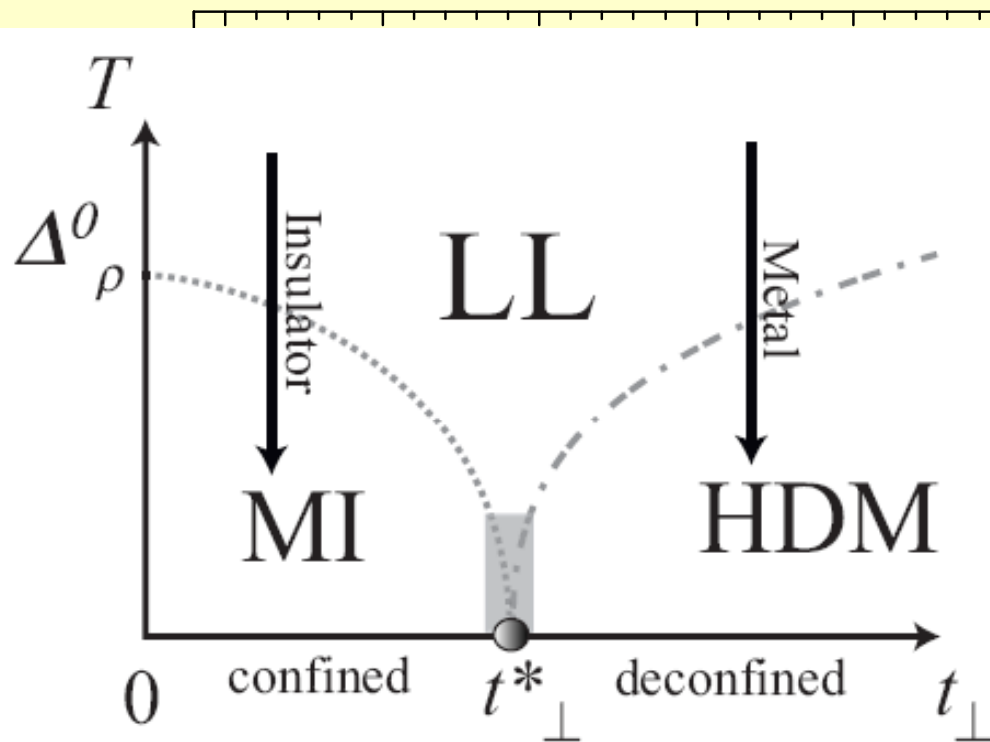

TG Chemical
Review 104 5037
(2004)

P. Auban-Senzier, D. Jérôme, C. Carcel and J.M. Fabre J de Physique IV, (2004)

A. Pashkin, M. Dressel, M. Hanfland, C. A. Kuntscher, arxiv/0909.4795

D. Jaccard et al., J. Phys. C, 13 L89 (2001)

Difficult to study

Difficult to study

S. Biermann, A. Georges, A. Lichtenstein, TG, PRL 87 276405 (2001)

C. Berthod et al. PRL 97, 136401 (2006)

Difficult to study

S. Biermann, A. Georges, A. Lichtenstein, TG, PRL 87 276405 (2001)

C. Berthod et al. PRL 97, 136401 (2006)

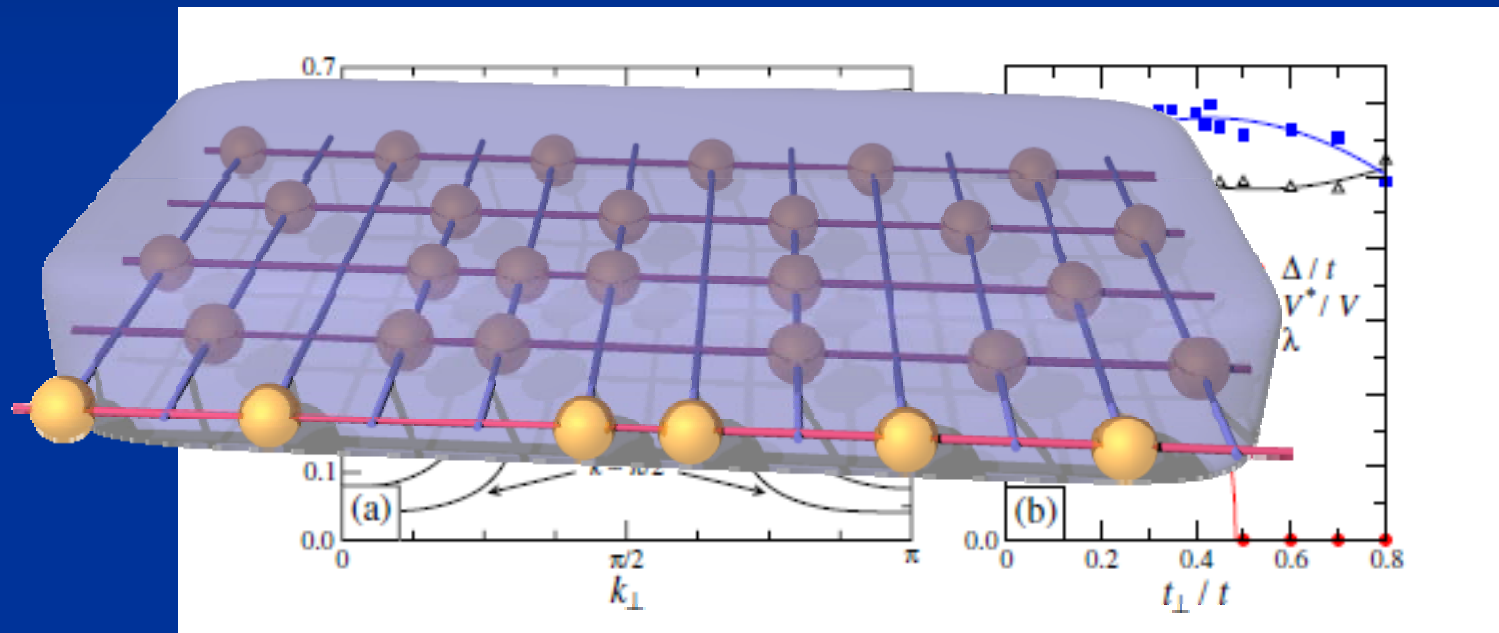

Difficult to study

S. Biermann, A. Georges, A. Lichtenstein, TG, PRL 87 276405 (2001)

C. Berthod et al. PRL 97, 136401 (2006)

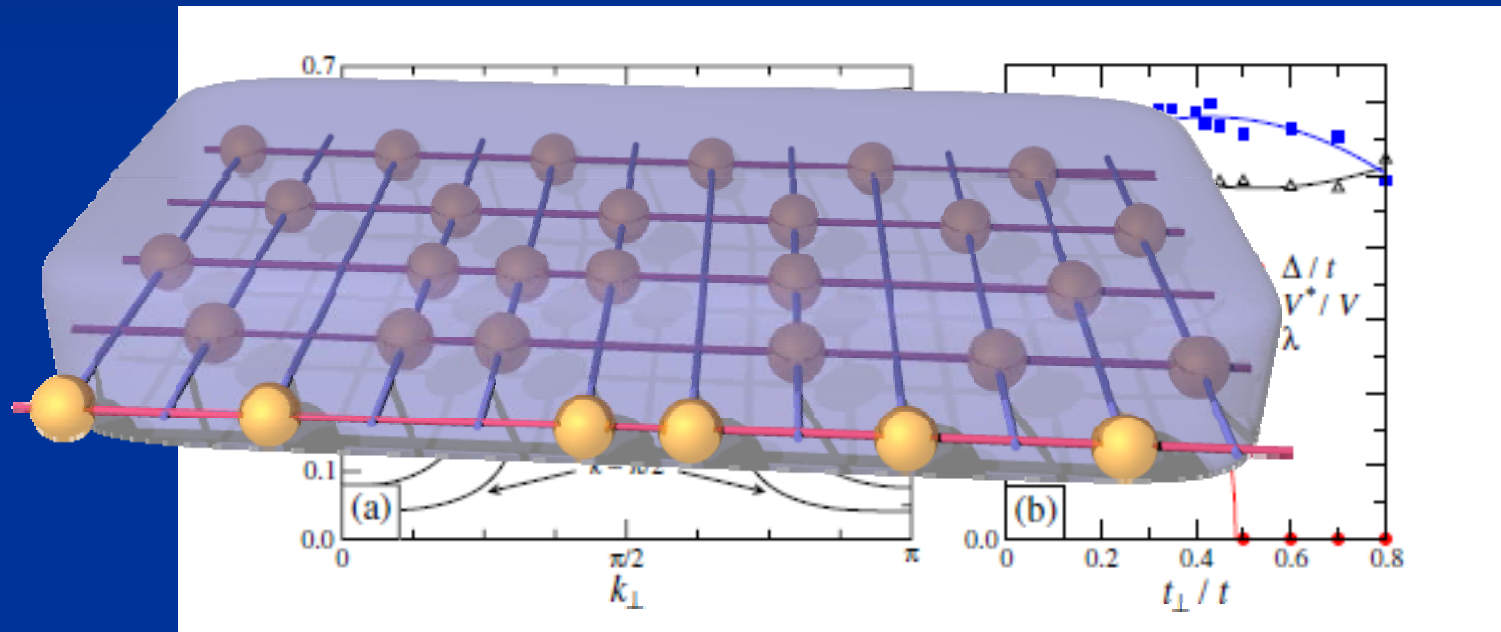

Two transitions ?

Ch-DMFT

Difficult to study

S. Biermann, A. Georges, A. Lichtenstein, TG, PRL 87 276405 (2001)

C. Berthod et al. PRL 97, 136401 (2006)

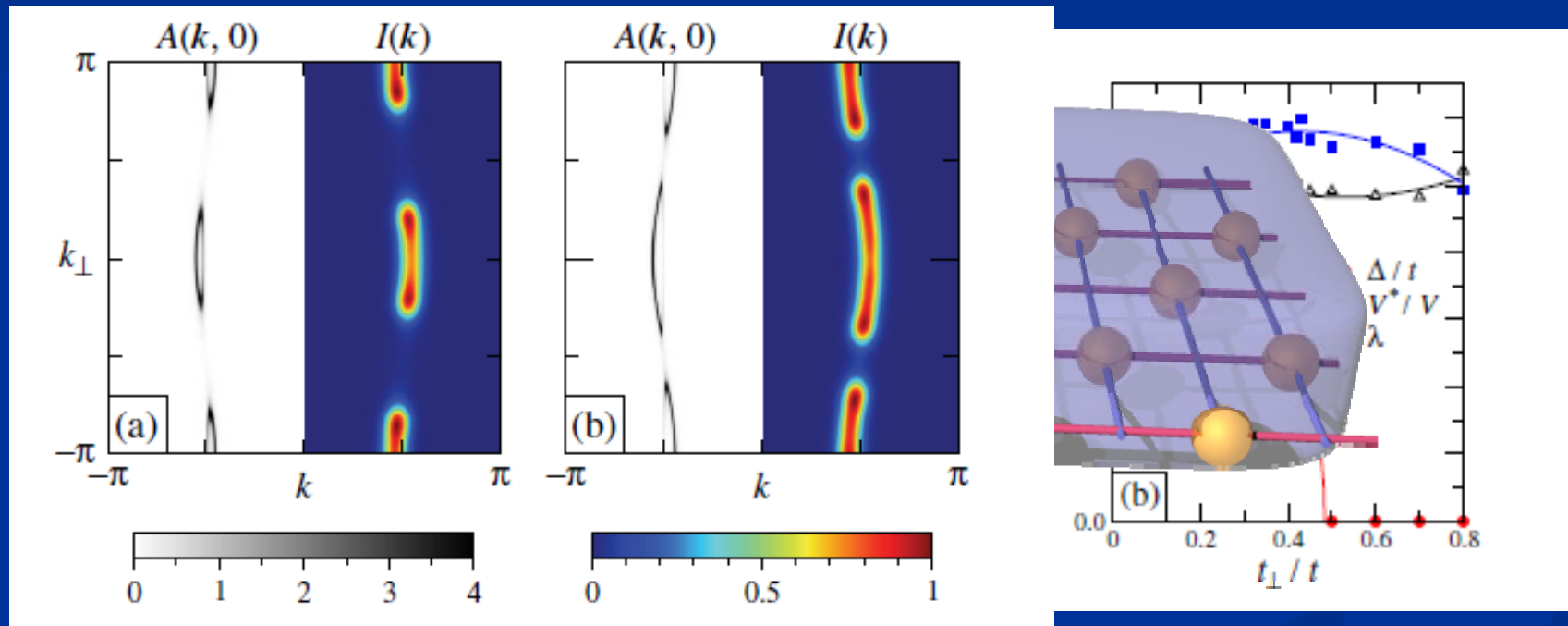

Two transitions ?

Nature of the phases ?

Ch-DMFT

Difficult to study

S. Biermann, A. Georges, A. Lichtenstein, TG, PRL 87 276405 (2001)

C. Berthod et al. PRL 97, 136401 (2006)

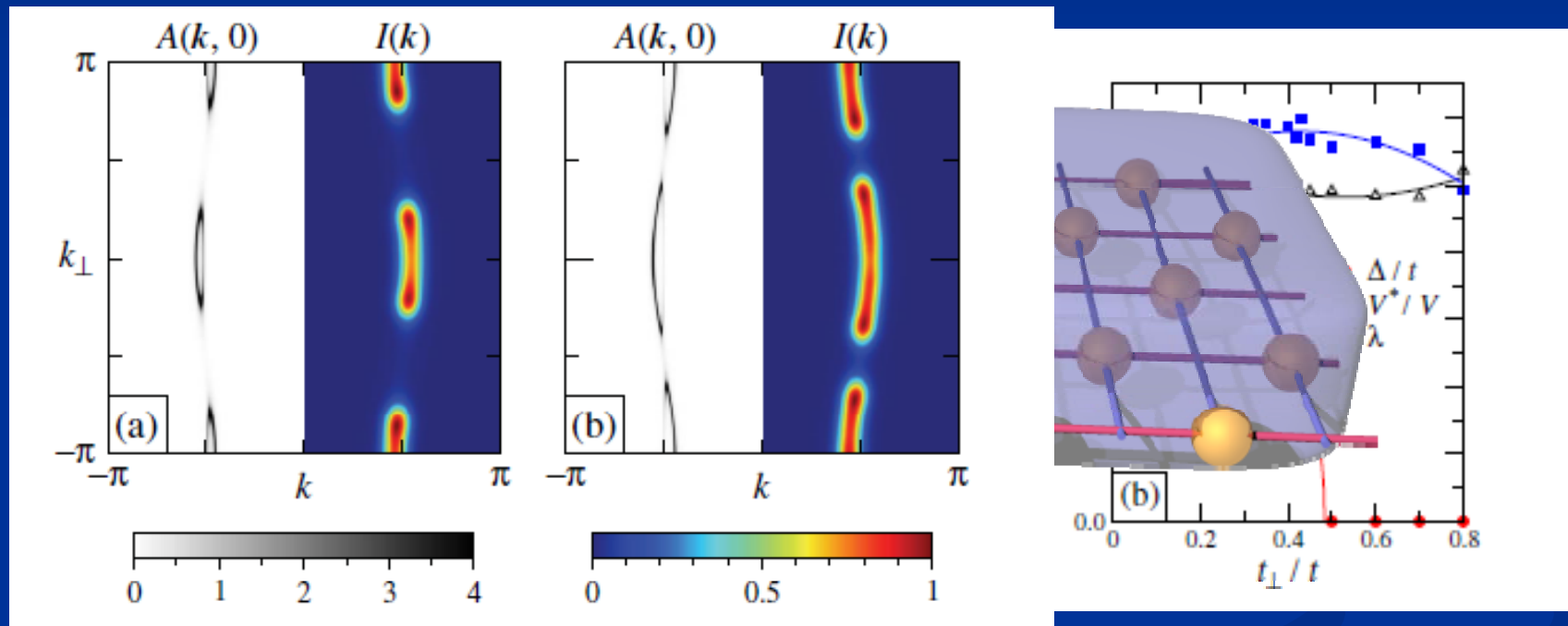

Two transitions ?

Nature of the phases ?

Ch-DMFT

Difficult to study

S. Biermann, A. Georges, A. Lichtenstein, TG, PRL 87 276405 (2001)

C. Berthod et al. PRL 97, 136401 (2006)

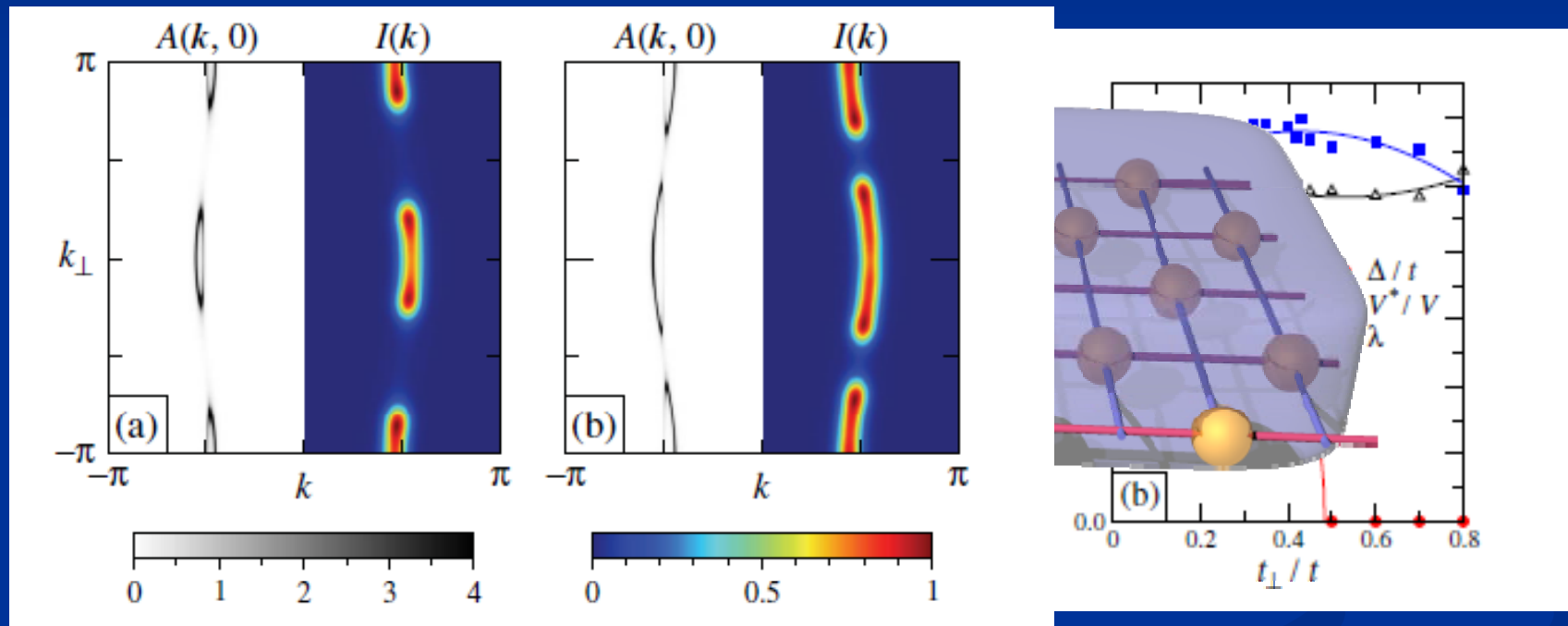

Two transitions ?

Nature of the phases ?

Ch-DMFT

Difficult to study

S. Biermann, A. Georges, A. Lichtenstein, TG, PRL 87 276405 (2001)

C. Berthod et al. PRL 97, 136401 (2006)

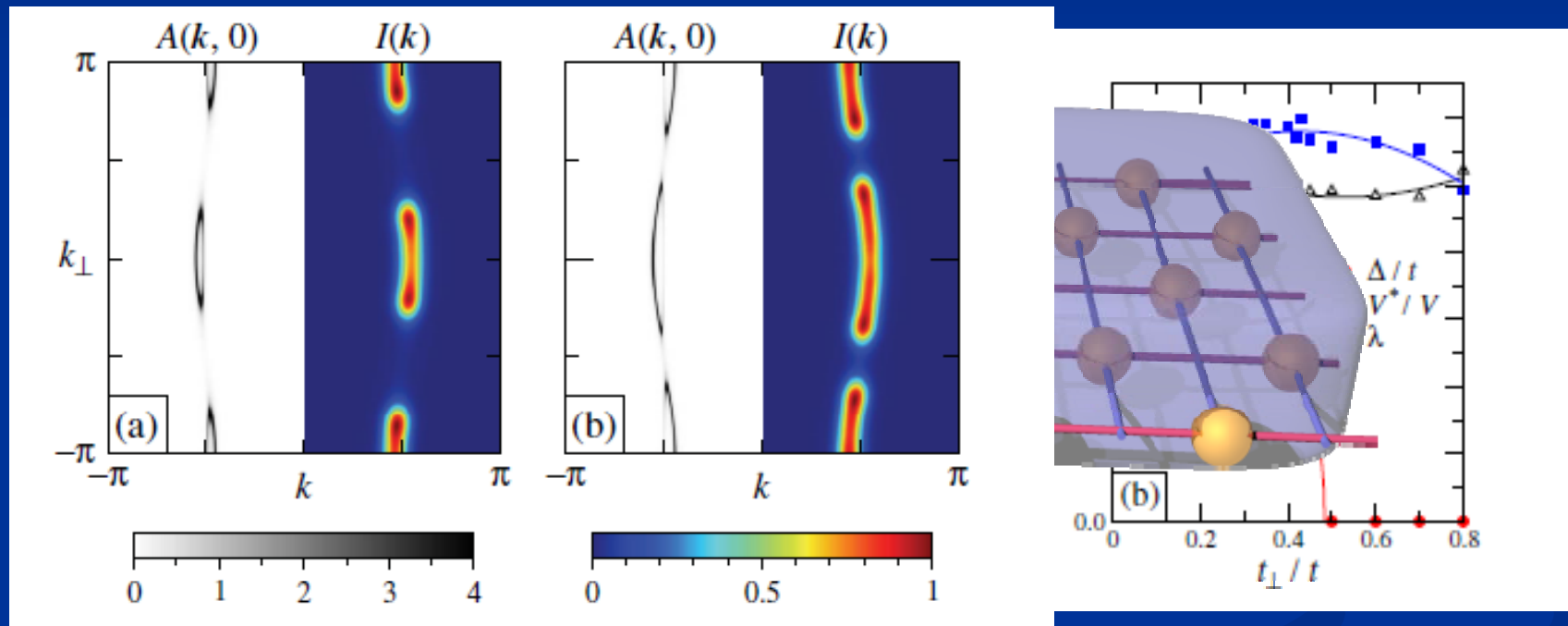

Two transitions ?

Nature of the phases ?

Ch-DMFT

Many open problems

Many open problems

- Tools to tackle the transition(s) ?

Many open problems

- Tools to tackle the transition(s) ?
- Other compounds ? (e.g. purple bronze)

Many open problems

- Tools to tackle the transition(s) ?
- Other compounds ? (e.g. purple bronze)
- Help from cold atomic systems ?

Many open problems

- Tools to tackle the transition(s) ?
- Other compounds ? (e.g. purple bronze)
- Help from cold atomic systems ?



Non Luttinger liquids





- Interacting 1D system (Luttinger liquid):
e.g. bosons -- “spin up”



- Interacting 1D system (Luttinger liquid):
e.g. bosons -- “spin up”
- Add one particle of “spin down”, or flip a spin



- Interacting 1D system (Luttinger liquid):
e.g. bosons -- “spin up”
- Add one particle of “spin down”, or flip a spin



- Interacting 1D system (Luttinger liquid):
e.g. bosons -- “spin up”
- Add one particle of “spin down”, or flip a spin

$$G_{\perp}(x, t) = \langle \uparrow | s_{+}(x, t) s_{-}(0, 0) | \uparrow \rangle$$



- Interacting 1D system (Luttinger liquid):
e.g. bosons -- “spin up”
- Add one particle of “spin down”, or flip a spin

$$G_{\perp}(x, t) = \langle \uparrow | s_{+}(x, t) s_{-}(0, 0) | \uparrow \rangle$$

- Example: two component bose-Hubbard model



- Interacting 1D system (Luttinger liquid):
e.g. bosons -- “spin up”
- Add one particle of “spin down”, or flip a spin

$$G_{\perp}(x, t) = \langle \uparrow | s_{+}(x, t) s_{-}(0, 0) | \uparrow \rangle$$

- Example: two component bose-Hubbard model

Behavior of the correlations ?

Behavior of the correlations ?

- $G_{\perp}(r,t)$ behaves as in a Luttinger liquid
(everything (?) is Luttinger liquid in 1D) ?
-

Behavior of the correlations ?

- $G_{\perp}(r,t)$ behaves as in a Luttinger liquid
(everything (?) is Luttinger liquid in 1D) ?

$$G_{\perp}(r,t) \sim \left(\frac{1}{r^2 + t^2} \right)^{\nu}$$



Behavior of the correlations ?

- $G_{\perp}(r,t)$ behaves as in a Luttinger liquid
(everything (?) is Luttinger liquid in 1D) ?

$$G_{\perp}(r,t) \sim \left(\frac{1}{r^2 + t^2} \right)^{\nu}$$

- $G_{\perp}(r,t)$ behaves as in a localized ferromagnet ?



Behavior of the correlations ?

- $G_{\perp}(r,t)$ behaves as in a Luttinger liquid
(everything (?) is Luttinger liquid in 1D) ?

$$G_{\perp}(r,t) \sim \left(\frac{1}{r^2 + t^2} \right)^{\nu}$$

- $G_{\perp}(r,t)$ behaves as in a localized ferromagnet ?



Behavior of the correlations ?

- $G_{\perp}(r,t)$ behaves as in a Luttinger liquid
(everything (?) is Luttinger liquid in 1D) ?

$$G_{\perp}(r,t) \sim \left(\frac{1}{r^2 + t^2} \right)^{\nu}$$

- $G_{\perp}(r,t)$ behaves as in a localized ferromagnet ?



Behavior of the correlations ?

- $G_{\perp}(r,t)$ behaves as in a Luttinger liquid
(everything (?) is Luttinger liquid in 1D) ?

$$G_{\perp}(r,t) \sim \left(\frac{1}{r^2 + t^2} \right)^{\nu}$$

- $G_{\perp}(r,t)$ behaves as in a localized ferromagnet ?



Behavior of the correlations ?

- $G_{\perp}(r,t)$ behaves as in a Luttinger liquid
(everything (?) is Luttinger liquid in 1D) ?

$$G_{\perp}(r,t) \sim \left(\frac{1}{r^2 + t^2} \right)^{\nu}$$

- $G_{\perp}(r,t)$ behaves as in a localized ferromagnet ?



Behavior of the correlations ?

- $G_{\perp}(r,t)$ behaves as in a Luttinger liquid
(everything (?) is Luttinger liquid in 1D) ?

$$G_{\perp}(r,t) \sim \left(\frac{1}{r^2 + t^2} \right)^{\nu}$$

- $G_{\perp}(r,t)$ behaves as in a localized ferromagnet ?



Behavior of the correlations ?

- $G_{\perp}(r,t)$ behaves as in a Luttinger liquid
(everything (?) is Luttinger liquid in 1D) ?

$$G_{\perp}(r,t) \sim \left(\frac{1}{r^2 + t^2} \right)^{\nu}$$

- $G_{\perp}(r,t)$ behaves as in a localized ferromagnet ?



Behavior of the correlations ?

- $G_{\perp}(r,t)$ behaves as in a Luttinger liquid
(everything (?) is Luttinger liquid in 1D) ?

$$G_{\perp}(r,t) \sim \left(\frac{1}{r^2 + t^2} \right)^{\nu}$$

- $G_{\perp}(r,t)$ behaves as in a localized ferromagnet ?



Behavior of the correlations ?

- $G_{\perp}(r,t)$ behaves as in a Luttinger liquid
(everything (?) is Luttinger liquid in 1D) ?

$$G_{\perp}(r,t) \sim \left(\frac{1}{r^2 + t^2} \right)^{\nu}$$

- $G_{\perp}(r,t)$ behaves as in a localized ferromagnet ?

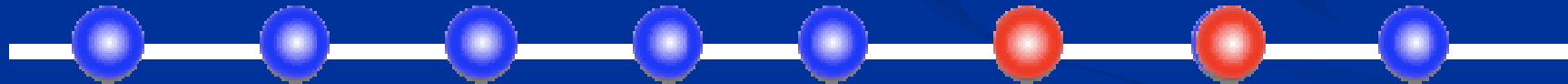

Behavior of the correlations ?

- $G_{\perp}(r,t)$ behaves as in a Luttinger liquid
(everything (?) is Luttinger liquid in 1D) ?

$$G_{\perp}(r,t) \sim \left(\frac{1}{r^2 + t^2} \right)^{\nu}$$

- $G_{\perp}(r,t)$ behaves as in a localized ferromagnet ?

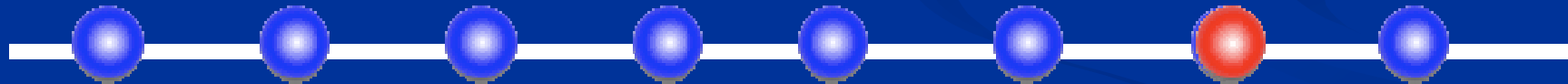

Behavior of the correlations ?

- $G_{\perp}(r,t)$ behaves as in a Luttinger liquid
(everything (?) is Luttinger liquid in 1D) ?

$$G_{\perp}(r,t) \sim \left(\frac{1}{r^2 + t^2} \right)^{\nu}$$

- $G_{\perp}(r,t)$ behaves as in a localized ferromagnet ?

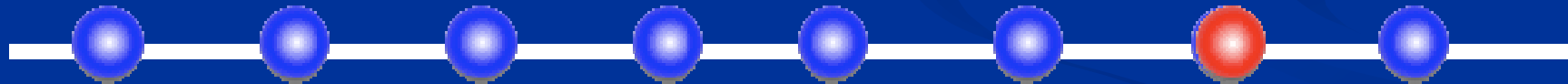

$$G_{\perp}^H(x,t) = \frac{1}{\sqrt{t}} e^{\frac{im^*x^2}{2t}}$$

Behavior of the correlations ?

- $G_{\perp}(r,t)$ behaves as in a Luttinger liquid
(everything (?) is Luttinger liquid in 1D) ?

$$G_{\perp}(r,t) \sim \left(\frac{1}{r^2 + t^2} \right)^{\nu}$$

- $G_{\perp}(r,t)$ behaves as in a localized ferromagnet ?

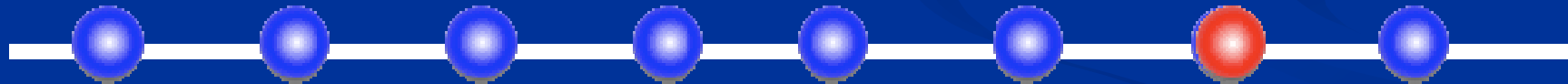

$$G_{\perp}^H(x,t) = \frac{1}{\sqrt{t}} e^{\frac{im^*x^2}{2t}}$$

Behavior of the correlations ?

- $G_{\perp}(r,t)$ behaves as in a Luttinger liquid
(everything (?) is Luttinger liquid in 1D) ?

$$G_{\perp}(r,t) \sim \left(\frac{1}{r^2 + t^2} \right)^{\nu}$$

- $G_{\perp}(r,t)$ behaves as in a localized ferromagnet ?

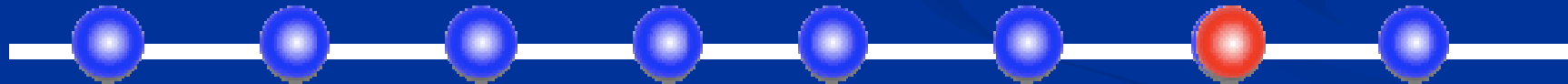

$$G_{\perp}^H(x,t) = \frac{1}{\sqrt{t}} e^{\frac{im^*x^2}{2t}}$$

- None of the above !

Behavior of the correlations ?

- $G_{\perp}(r,t)$ behaves as in a Luttinger liquid
(everything (?) is Luttinger liquid in 1D) ?

$$G_{\perp}(r,t) \sim \left(\frac{1}{r^2 + t^2} \right)^{\nu}$$

- $G_{\perp}(r,t)$ behaves as in a localized ferromagnet ?

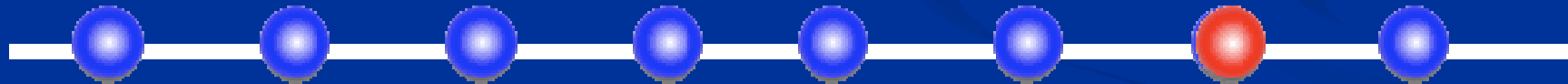

$$G_{\perp}^H(x,t) = \frac{1}{\sqrt{t}} e^{\frac{im^*x^2}{2t}}$$

- None of the above !

Transverse spin excitations

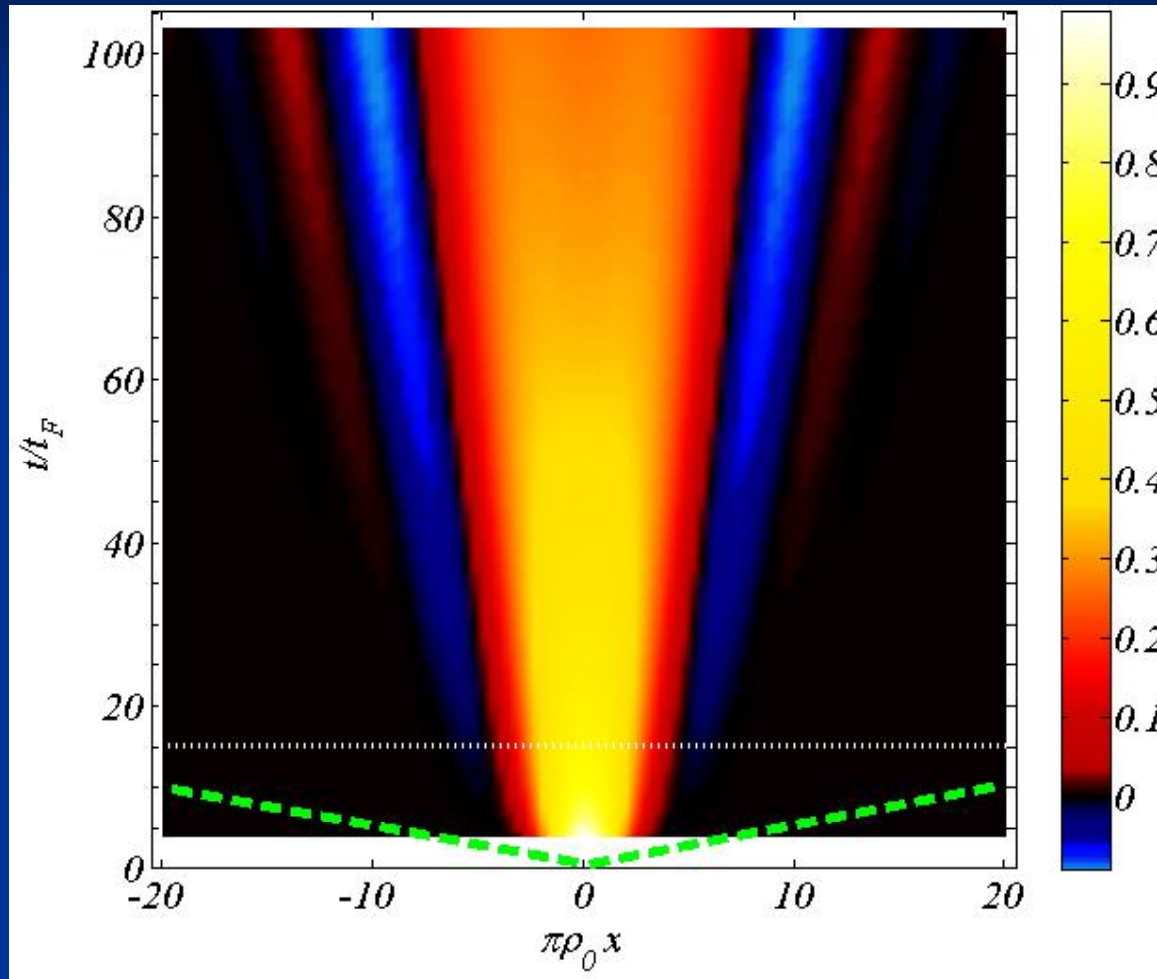

Transverse spin excitations

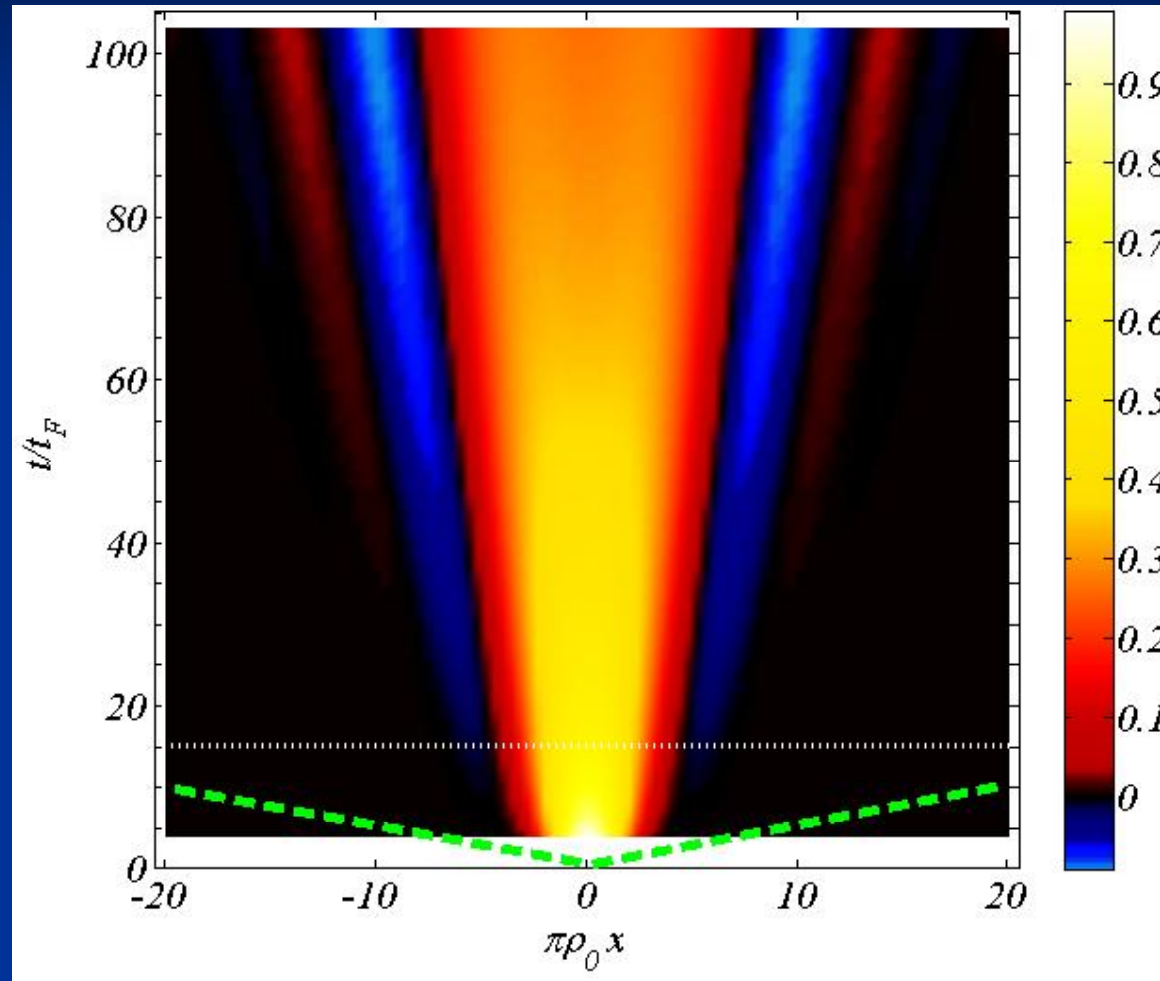

M. B. Zvonarev, V. V. Cheianov, TG, PRL 99 240404 (2007)

Interest

Interest

- Novel universality class: not a Luttinger liquid in one dimension ! To be explored.....

Interest

- Novel universality class: not a Luttinger liquid in one dimension ! To be explored.....
- Connection with other problems: mobile impurity in a LL (X-ray edge – Nozieres), Caldeira-Leggett problem.

Interest

- Novel universality class: not a Luttinger liquid in one dimension ! To be explored.....
- Connection with other problems: mobile impurity in a LL (X-ray edge – Nozieres), Caldeira-Leggett problem.
- Realization with cold atoms (?):
e.g. ^{87}Rb ; Dynamical correlations.

Interest

- Novel universality class: not a Luttinger liquid in one dimension ! To be explored.....
- Connection with other problems: mobile impurity in a LL (X-ray edge – Nozieres), Caldeira-Leggett problem.
- Realization with cold atoms (?):
e.g. ^{87}Rb ; Dynamical correlations.
- Mobile impurity: S. Palzer et al. PRL 103 150601

Conclusions

Conclusions

- Tour of one dimensional physics

Conclusions

- Tour of one dimensional physics
- Luttinger liquid theory provides a framework to study this physics, and to go beyond

Conclusions

- Tour of one dimensional physics
- Luttinger liquid theory provides a framework to study this physics, and to go beyond
- Many effects: lattice, disorder, long range forces, competition between orders, out of equilibrium physics,

Conclusions

- Tour of one dimensional physics
- Luttinger liquid theory provides a framework to study this physics, and to go beyond
- Many effects: lattice, disorder, long range forces, competition between orders, out of equilibrium physics,
- Many experimental realizations: organics, spin systems, nanowire, nanotubes, adatoms, FRQHE, Joseph. junctions, cold atoms,